

WORTEX
MOBLEX

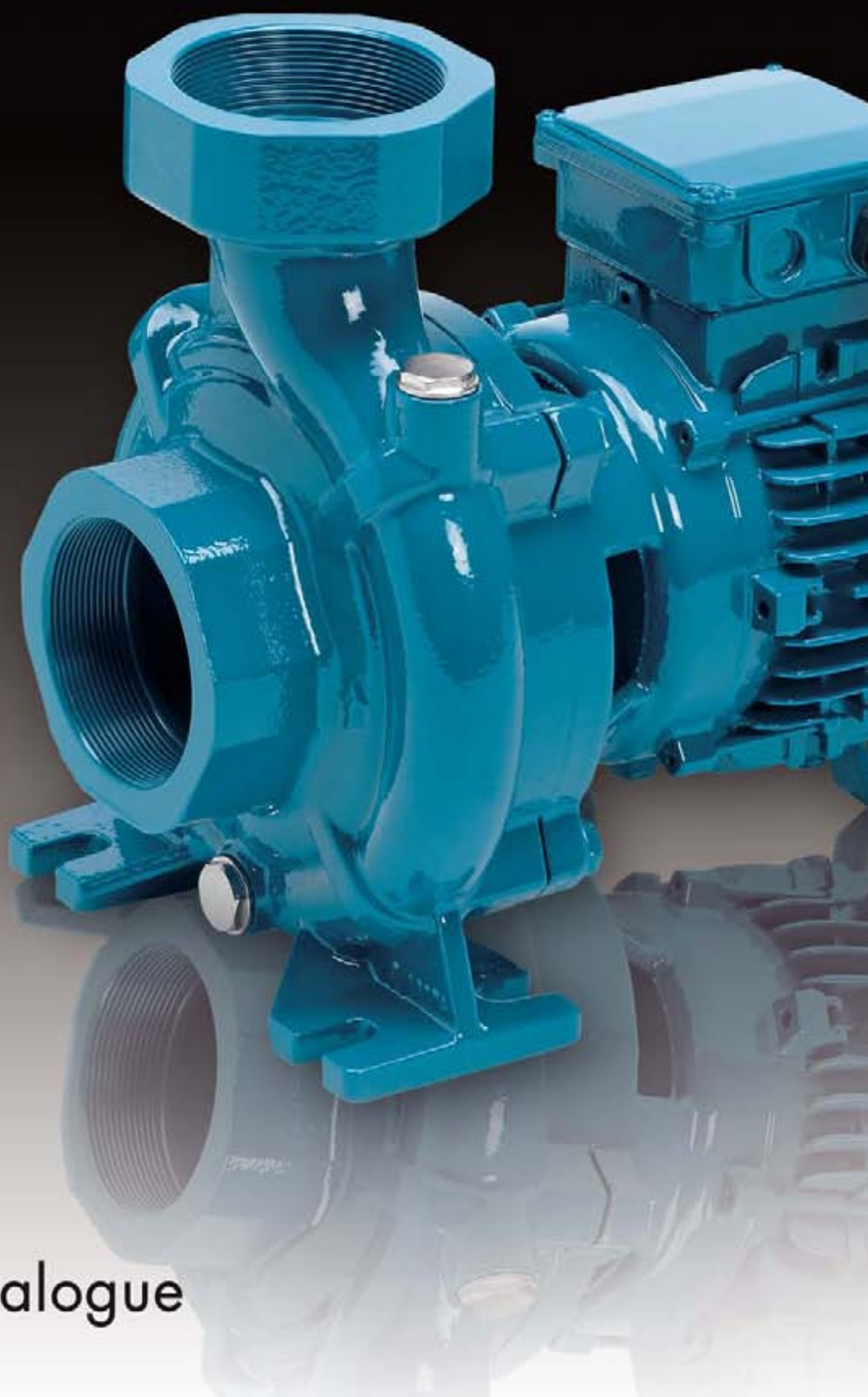

General Catalogue



Note Tecniche di Prodotto.

I dati e le caratteristiche tecniche riportate nel presente Catalogo Generale non sono impegnativi. La COSPET si riserva il diritto di apportare qualsiasi modifica senza alcun preavviso. Di conseguenza pesi, misure, prestazioni e quanto altro indicato non sono vincolanti ma solo indicativi. In ogni caso, per qualsiasi dettaglio tecnico richiedere direttamente alla COSPET la scheda tecnica aggiornata del prodotto.

Foro Competente.

Per eventuali controversie, il Foro competente sarà quello di Reggio Emilia anche se il pagamento é avvenuto a mezzo tratta.

Technical Characteristics.

The technical data and characteristics stated in this General Catalogue are not binding. COSPET reserves the right to make modifications without notice. Therefore weights, dimensions, performances and any other stated issues are indicative only and not binding. Anyway for any technical details you must require an up-to-date product technical card.

Competent Court.

In case of any dispute the competent Court will be one of Reggio Emilia even if the payment is by bill of exchange.

PM - FM

ELETTROPOMPE VOLUMETRICHE
VOLUMETRIC PUMPS



pag 2

PM-A

ELETTROPOMPA AUTOADESCANTE VOLUMETRICA
SELFPRIMING VOLUMETRIC PUMP



pag 3

JET

ELETTROPOMPE AUTOADESCANTI JET
SELFPRIMING JET PUMPS



pag 4/6

CNB

ELETTROPOMPE CENTRIFUGHE BIGIRANTI
TWIN IMPELLER CENTRIFUGAL PUMPS



pag 7

JAP

ELETTROPOMPE AUTODESCANTI PER ASPIRAZIONI PROFONDE
SELFPRIMING PUMPS FOR DEEP SUCTION



pag 8/9

C

ELETTROPOMPE CENTRIFUGHE MONOGRIRANTI
SINGLE IMPELLER CENTRIFUGAL PUMPS



pag 10

CB

ELETTROPOMPE CENTRIFUGHE BIGIRANTI
TWIN IMPELLER CENTRIFUGAL PUMPS



pag 11/13

CH

ELETTROPOMPE CENTRIFUGHE MONOGRIRANTI
SINGLE IMPELLER CENTRIFUGAL PUMPS



pag 14/15

CF

ELETTROPOMPE CENTRIFUGHE DI SCORRIMENTO
CENTRIFUGAL IRRIGATION PUMPS



pag 16/17

CN

ELETTROPOMPE CENTRIFUGHE MONOBLOCCO
MONOBLOCK CENTRIFUGAL PUMPS



pag 18/23

JX

ELETTROPOMPE AUTOADESCANTI
JET INOX
SELFPRIMING JET INOX PUMPS



pag 24

MJX

ELETTROPOMPA CENTRIFUGA AUTOADESCANTE MULTISTADIO
CENTRIFUGAL SELFPRIMING MULTISTAGE PUMP



pag 25

COMBI

GRUPPO DI PRESSURIZZAZIONE A FUNZIONAMENTO AUTOMATICO
AUTOMATIC WORKING PRESSURE SYSTEM



pag 26/29

MULTI-G

ELETTROPOMPE CENTRIFUGHE MULTIGIRANTI
CENTRIFUGAL MULTI-IMPELLER PUMPS



pag 30/31

MULTI-GA

ELETTROPOMPE AUTOADESCANTI CENTRIFUGHE MULTIGIRANTI
SELF PRIMING CENTRIFUGAL MULTI-IMPELLER PUMPS



pag 32

MULTI-VG

ELETTROPOMPE MULTISTADIO
AD ASSE VERTICALE
MULTISTAGE VERTICAL ELECTRIC
PUMPS



pag 33

DIG

ELETTROPOMPE AUTOADESCANTI MONOBLOCCO
SELFPRIMING MONOBLOCK PUMPS



pag 34

BP

ELETTROPOMPE
AUTOADESCANTI IN BRONZO
SELFPRIMING BRONZE PUMPS



pag 35

JD

ELETTROPOMPE SOMMERSE
PER DRENAGGIO
SUBMERSIBLE DRAINAGE PUMPS



pag 36

JV

ELETTROPOMPE SOMMERSE
PER ACQUE CARICHE
SUBMERSIBLE PUMPS
FOR DIRTY WATER



pag 37

JDX

ELETTROPOMPE SOMMERSE
INOX PER DRENAGGIO
STAINLESS STEEL SUBMERSIBLE
DRAINAGE PUMPS



pag 38



JVX
ELETROPOMPE SOMMERSE INOX
PER ACQUE CARICHE
STAINLESS STEEL SUBMERSIBLE
PUMPS FOR DIRTY WATER
pag 39



DXG
ELETROPOMPE SOMMERSE INOX
PER DRENAGGIO
STAINLESS STEEL SUBMERSIBLE
DRAINAGE PUMPS
pag 40/41



PROFI
ELETROPOMPE SOMMERSE
PER DRENAGGIO
SUBMERSIBLE ELECTRIC PUMP
FOR THE DRAINAGE
pag 42/47



TURBINE
ELETROPOMPA SOMMERSA
PERIFERICA PER POZZI 4"
PERIPHERAL TURBINE SUBMERSIBLE
PUMP FOR 4" WELLS
pag 48



MC
ELETROPOMPA SOMMERSA
MULTISTADIO
MULTISTAGE SUBMERSIBLE
PUMP
pag 49



SUB
ELETROPOMPE SOMMERSE
MULTISTADIO PER POZZI 6"
MULTISTAGE SUBMERSIBLE
PUMPS FOR 6" WELLS
pag 50/51



DRAIN
SEWAGE PUMPS
pag 52/53



VORT
SEWAGE PUMPS
pag 54/55



A316
SEWAGE PUMPS
pag 56



GRINDER
SEWAGE PUMPS
pag 57



AS-AS1
SEWAGE PUMPS
pag 58/59



CB-CBI pag 60/63
ELETROPOMPE ORIZZONTALI CENTRIFUGHE MULTISTADIO
HORIZONTAL MULTISTAGE CENTRIFUGAL PUMPS



HBI
ELETROPOMPE ORIZZONTALI
CENTRIFUGHE MULTISTADIO
HORIZONTAL MULTISTAGE
CENTRIFUGAL PUMPS
pag 64/65



SBI
ELETROPOMPE VERTICALI
MULTISTADIO ACCIAIO INOX
VERTICAL MULTISTAGE
STAINLESS STEEL PUMPS
pag 66/73



ST
POMPE SOMMERSE MULTISTADIO
PER POZZI 4"
MULTISTAGE SUBMERSIBLE PUMPS
FOR 4" WELLS
pag 74/82



SP
POMPE SOMMERSE INOX MULTISTADIO
PER POZZI 4"/6"
INOX MULTISTAGE SUBMERSIBLE PUMPS
FOR 4"/6" WELLS
pag 83/93



MWM-MW
MOTORI SOMMERSE MONOFASE
MULTISTADIO PER POZZI 4"
SINGLE-PHASE MULTISTAGE
SUBMERSIBLE MOTORS FOR 4" WELLS
pag 94/95

Pressure TANK

WATER TANKS FOR ALL
WATER SYSTEMS:
INDUSTRIAL, DOMESTIC
AND AGRICULTURAL
pag 96



ACCESSORI ACCESSORIES

pag 97/100



ELETTROPOMPE VOLUMETRICHE VOLUMETRIC PUMPS



PM

LIMITI D'IMPIEGO

- Temperatura liquido fino a 60°C
- Temperatura ambiente fino a 40°C
- Altezza d'aspirazione manometrica fino a 7 mt.
- Servizio continuo

MOTORE

- Motore elettrico ad induzione a 2 poli (n = 2850 r.p.m.)
- Isolamento Classe F
- Protezione IP 44

MATERIALI

- | | |
|-------------------------|------------------|
| - Corpo pompa | Ghisa |
| - Supporto motore | Ghisa |
| - Coperchio corpo pompa | Ottone (FM) |
| - Girante | Ottone |
| - Albero motore | Acciaio Inox |
| - Tenute meccaniche | Ceramica/Carbone |

OPERATING CONDITIONS

- Liquid temperature up to 60°C
- Ambient temperature up to 40°C
- Total suction lift up to 7 mt.
- Continuous duty

MOTOR

- Two-Pole induction motor (n = 2850 r.p.m.)
- Insulation Class F
- Protection IP 44

MATERIALS

- | | |
|--------------------|-----------------|
| - Pump body | Cast Iron |
| - Motor Support | Cast Iron |
| - Pump body cover | Brass (FM) |
| - Impeller | Brass |
| - Shaft with rotor | Stainless/Steel |
| - Mechanical seal | Carbon/Ceramic |



FM

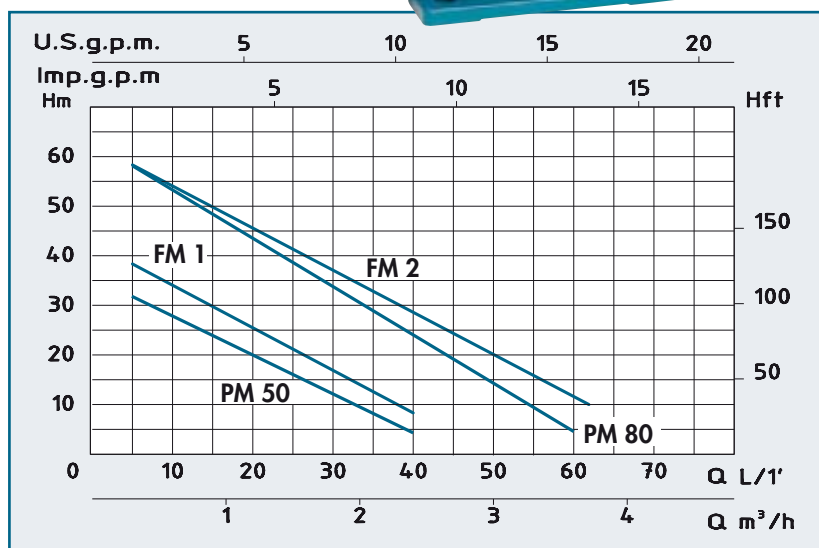

TIPO - TYPE	POTENZA NOMINALE NOMINAL POWER P2		AMPERE	Q = PORTATA - CAPACITY											Dimensioni Dimensions			
				Monofase Single-phase	m³/h	0,3	0,6	1	1,2	1,5	1,8	2,1	2,4	3			3,6	
230V-50Hz	HP	kW	1 x 230V		Prevalenza manometrica totale in m.C.A. - Total head in meters w.c.											DNA	DNM	
PM 50	0,5	0,37	2,9	H (m)	34	30	25	22	17	13	10						1"	1"
PM 80	0,8	0,6	3,8		59	55	50	45	40	35	30	25	15				1"	1"

TIPO - TYPE	POTENZA NOMINALE NOMINAL POWER P2		AMPERE	Q = PORTATA - CAPACITY											Dimensioni Dimensions			
				Monofase Single-phase	m³/h	0,3	0,6	1	1,2	1,5	1,8	2,1	2,4	3			3,6	
230V-50Hz	HP	kW	1 x 230V		Prevalenza manometrica totale in m.C.A. - Total head in meters w.c.											DNA	DNM	
FM 1	0,5	0,37	2,9	H (m)	38	35	30	26	21	17	13	8					1"	1"
FM 2	0,8	0,6	3,8		58	54	50	45	42	38	33	28	20	12			1"	1"

ELETTROPOMPA AUTOADESCANTE VOLUMETRICA SELFPRIMING VOLUMETRIC PUMP



LIMITI D'IMPIEGO

- Temperatura liquido fino a 60°C
- Temperatura ambiente fino a 40°C
- Altezza d'aspirazione manometrica fino a 7 mt.
- Servizio continuo

MOTORE

- Motore elettrico ad induzione a 2 poli (n = 2850 r.p.m.)
- Isolamento Classe F
- Protezione IP 44

MATERIALI

- Corpo pompa Ghisa
- Supporto motore Ghisa
- Girante Ottone
- Albero motore Acciaio Inox
- Tenute meccaniche Ceramica/Carbone

OPERATING CONDITIONS

- Liquid temperature up to 60°C
- Ambient temperature up to 40°C
- Total suction lift up to 7 mt.
- Continuous duty

MOTOR

- Two-Pole induction motor (n = 2850 r.p.m.)
- Insulation Class F
- Protection IP 44

MATERIALS

- Pump body Cast Iron
- Motor Support Cast Iron
- Impeller Brass
- Shaft with rotor Stainless/Steel
- Mechanical seal Carbon/Ceramic

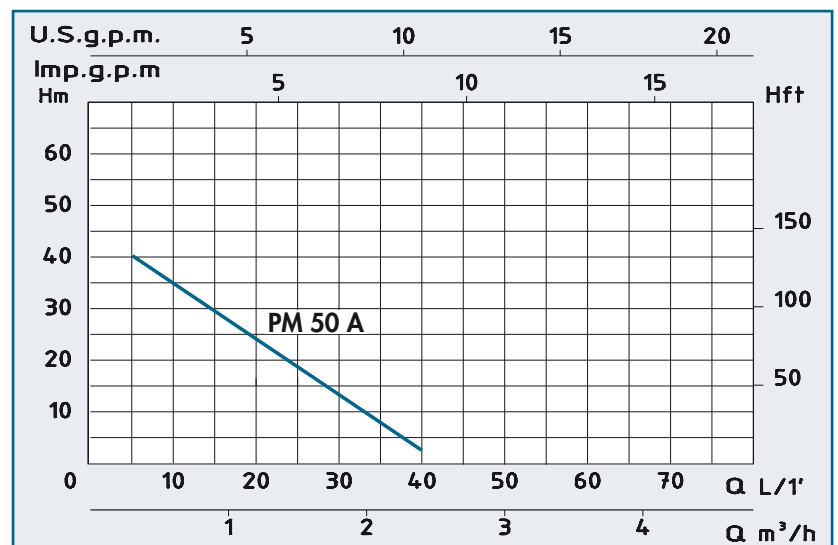

TIPO - TYPE	POTENZA NOMINALE NOMINAL POWER P2		AMPERE	Q = PORTATA - CAPACITY												
				Prevalenza manometrica totale in m.C.A. - Total head in meters w.c.												
Monofase Single-phase	HP	kW	1 x 230V	m³/h	0,3	0,6	1	1,2	1,5	1,8	2,1	2,4	3	3,6	Dimensioni Dimensions	
230V-50Hz				lt/1'	5	10	16	20	25	30	35	40	50	60		
PM 50 A	0,6	0,45	3,1	H (m)	40	35	30	24	18	12	7	2			DNA	DNM
															1"	1"

ELETTROPOMPE AUTOADESCANTI JET SELFPRIMING JET PUMPS

LIMITI D'IMPIEGO

- Pressione max. d'esercizio 6 bar
- Pressione max. d'esercizio 8 bar (Jet100)
- Temperatura liquido fino a 35° C
- Temperatura ambiente fino a 40° C
- Altezza d'aspirazione manometrica fino a 8 mt.
- Servizio continuo

MOTORE

- Motore elettrico ad induzione a 2 poli (n = 2850 min⁻¹)
- Isolamento Classe F
- Protezione IP 44

MATERIALI

- Corpo pompa Ghisa
- Supporto motore Alluminio
- Girante Noryl
- Girante Acciaio Inox (Jet100)
- Diffusore Noryl
- Flangia portatenuta Acciaio Inox
- Albero motore Acciaio Inox
- Tenute meccaniche Ceramica/Carbone



OPERATING CONDITIONS

- Max. working pressure 6 bar
- Max. working pressure 8 bar (Jet100)
- Liquid temperature up to 35°C
- Ambient temperature up to 40°C
- Total suction lift up to 8 mt.
- Continuous duty

MOTOR

- Two-Pole induction motor (n = 2850 min⁻¹)
- Insulation Class F
- Protection IP 44

MATERIALS

- Pump body Cast Iron
- Motor Support Aluminium
- Impeller Noryl
- Impeller Stainless Steel (Jet100)
- Diffuser Noryl
- Pump flange Stainless Steel
- Shaft with rotor Stainless Steel
- Mechanical seal Carbon/Ceramic

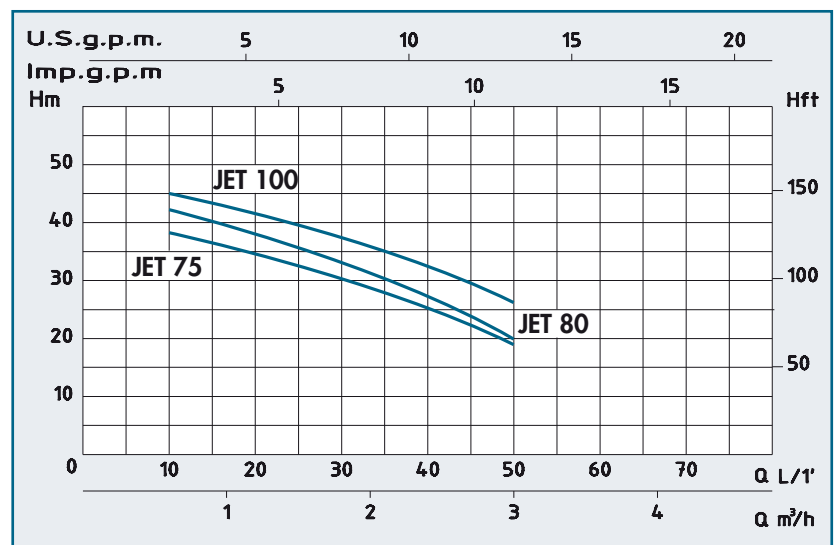

TIPO - TYPE	POTENZA NOMINALE NOMINAL POWER		AMPERE	Q = PORTATA - CAPACITY											Dimensioni Dimensions	
				Monofase Single-phase	m³/h	0,6	0,9	1,2	1,5	1,8	2,1	2,4	2,7	3	3,6	DNA
230V-50Hz	HP	kW	1 x 230V	Prevalenza manometrica totale in m.C.A. - Total head in meters w.c.												
JET 75	0,8	0,6	3,8	H (m)	38	36	34	32	29	27	25	22	19		1"	1"
JET 80	0,8	0,6	3,8		42	38	36	33	30	27	26	23	20		1"	1"
JET 100	1	0,75	5		45	43	40	38	35	33	30	29	26	22	1"	1"

ELETTROPOMPE AUTOADESCANTI JET SELFPRIMING JET PUMPS

LIMITI D'IMPIEGO

- Pressione max. d'esercizio 8 bar
- Temperatura liquido fino a 35° C
- Temperatura ambiente fino a 40° C
- Altezza d'aspirazione manometrica fino a 8 mt.
- Servizio continuo

MOTORE

- Motore elettrico ad induzione a 2 poli ($n = 2850 \text{ min}^{-1}$)
- Isolamento Classe F
- Protezione IP 44

MATERIALI

- Corpo pompa Ghisa
- Supporto motore Ghisa
- Girante Ottone
- Diffusore Noryl
- Flangia portatenuta Acciaio Inox
- Albero motore Acciaio Inox
- Tenute meccaniche Ceramica/Carbone



OPERATING CONDITIONS

- Max. working pressure 8 bar
- Liquid temperature up to 35°C
- Ambient temperature up to 40°C
- Total suction lift up to 8 mt.
- Continuous duty

MOTOR

- Two-Pole induction motor ($n = 2850 \text{ min}^{-1}$)
- Insulation Class F
- Protection IP 44

MATERIALS

- Pump body Cast Iron
- Motor Support Cast Iron
- Impeller Brass
- Diffuser Noryl
- Pump flange Stainless Steel
- Shaft with rotor Stainless Steel
- Mechanical seal Carbon/Ceramic

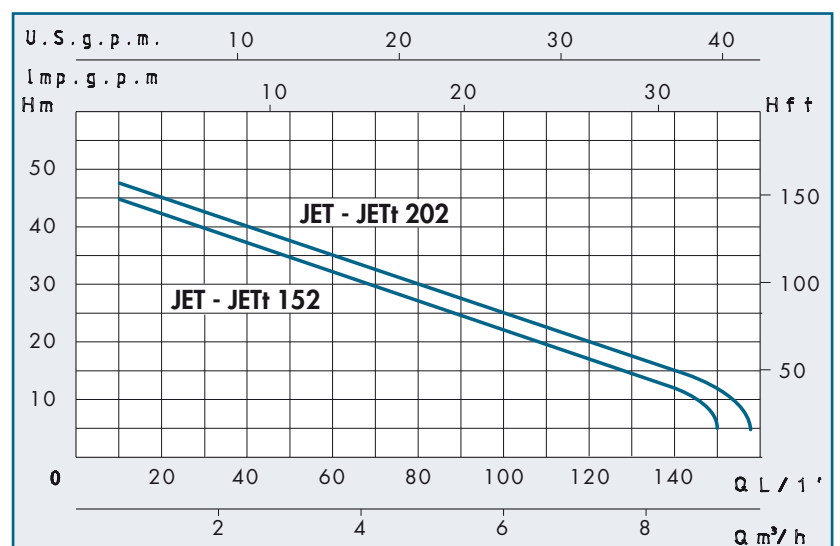

TIPO - TYPE		POTENZA NOMINALE NOMINAL POWER P2		AMPERE		Q = PORTATA - CAPACITY												
Monofase Single-phase	Trifase Three-phase	HP	kW	Monofase Single-phase	Trifase Three-phase	m³/h	0,6	1,2	1,8	2,7	3,6	4,8	5,4	6	7,5	9	Dimensioni Dimensions	
230V-50Hz	230/400V-50Hz			1 x 230V	3 x 400V	lt/1'	10	20	30	45	60	80	90	100	125	150	DNA	DNM
JET 152	JET t 152	1,5	1,1	7	3	H	45	42	40	36	33	27	25	22	16	10	1 1/4	1"
JET 202	JET t 202	2	1,5	9,3	4,2	(m)	47	45	43	39	35	30	27	25	18	13	1 1/4	1"

ELETTROPOMPE AUTOADESCANTI BIGIRANTI TWIN IMPELLER SELFPRIMING PUMPS



LIMITI D'IMPIEGO

- Temperatura liquido fino a 35° C
- Temperatura ambiente fino a 40° C
- Altezza d'aspirazione manometrica fino a 9 mt.
- Servizio continuo

MOTORE

- Motore elettrico ad induzione a 2 poli (n = 2850 min⁻¹)
- Isolamento Classe F
- Protezione IP 44

MATERIALI

- Corpo pompa Ghisa
- Supporto motore Ghisa
- Girante Noryl
- Diffusore Noryl
- Eiettore Ghisa
- Albero motore Acciaio Inox
- Tenute meccaniche Ceramica/Carbone

OPERATING CONDITIONS

- Liquid temperature up to 35°C
- Ambient temperature up to 40°C
- Total suction lift up to 9 mt.
- Continuous duty

MOTOR

- Two-Pole induction motor (n = 2850 min⁻¹)
- Insulation Class F
- Protection IP 44

MATERIALS

- Pump body Cast Iron
- Motor Support Cast Iron
- Impeller Noryl
- Diffuser Noryl
- Ejector Cast Iron
- Shaft with rotor Stainless Steel
- Mechanical seal Carbon/Ceramic

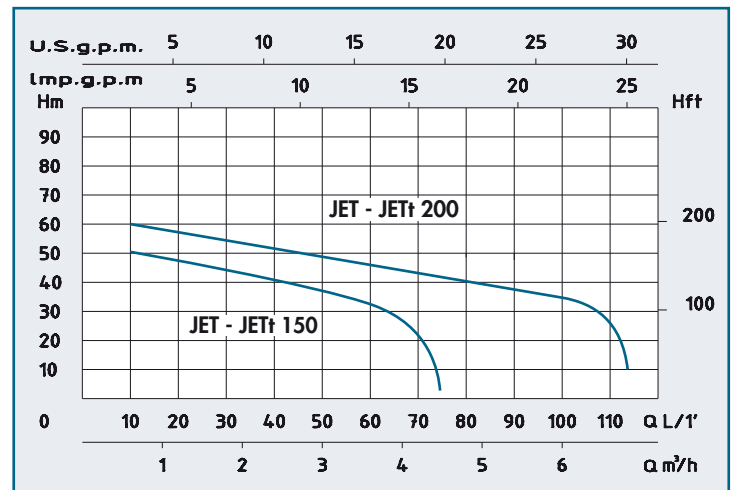

TIPO - TYPE		POTENZA NOMINALE NOMINAL POWER P2		AMPERE		Q = PORTATA - CAPACITY												
Monofase Single-phase	Trifase Three-phase	HP	kW	Monofase Single-phase	Trifase Three-phase	m³/h	0,6	1,2	1,8	2,4	3	3,6	4,2	4,8	5,4	6	Dimensioni Dimensions	
230V-50Hz	230/400V-50Hz			1 x 230V	3 x 400V	lt/1'	10	20	30	40	50	60	70	80	90	100	DNA	DNM
JET 150	JET t 150	1,5	1,1	7	3	H	58	55	51	47	42	40	35				1"½	1"
JET 200	JET t 200	2	1,5	9,3	4,2	(m)	60	57	53	50	47	45	44	40	38	35	1"½	1"

ELETTROPOMPE CENTRIFUGHE BIGIRANTI TWIN IMPELLER CENTRIFUGAL PUMPS

LIMITI D'IMPIEGO

- Temperatura liquido fino a 35°C
- Temperatura ambiente fino a 40°C
- Altezza d'aspirazione manometrica fino a 9 mt.
- Servizio continuo

MOTORE

- Motore elettrico ad induzione a 2 poli ($n = 2850 \text{ min}^{-1}$)
- Isolamento Classe F
- Protezione IP 44

MATERIALI

- Corpo pompa Ghisa
- Supporto motore Ghisa
- Girante Noryl
- Diffusore Noryl
- Albero motore Acciaio Inox
- Tenute meccaniche Ceramica/carbone

OPERATING CONDITIONS

- Liquid temperature up to 35°C
- Ambient temperature up to 40°C
- Total suction lift up to 9 mt.
- Continuous duty

MOTORS

- Two-Pole induction motor ($n = 2850 \text{ min}^{-1}$)
- Insulation Class F
- Protection IP 44

MATERIALS

- Pump body Cast Iron
- Motor Support Cast Iron
- Impeller Noryl
- Diffuser Noryl
- Shaft with rotor Stainless Steel
- Mechanical seal Carbon/Ceramic

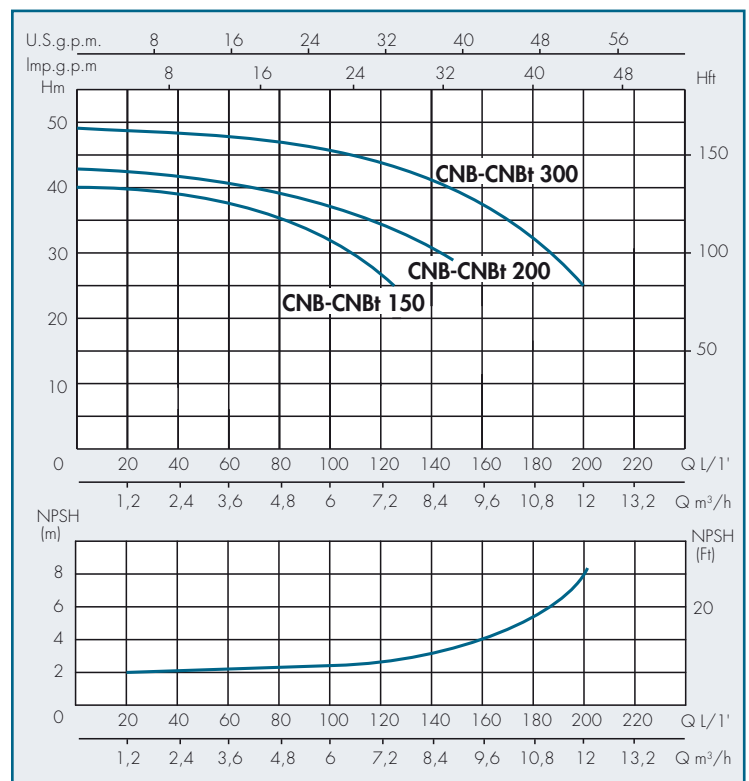

TIPO - TYPE		POTENZA NOMINALE NOMINAL POWER P2		AMPERE		Q = PORTATA - CAPACITY										Dimensioni Dimensions			
Monofase Single-phase	Trifase Three-phase			Monofase Single-phase	Trifase Three-phase	m³/h	0	1,5	3	4,5	6	7,5	9	12	18	21	DNA	DNM	
230V-50Hz	230/400V-50Hz	HP	kW	1 x 230V	3 x 400V	lt/1'	0	25	50	75	100	125	150	200	300	350			
CNB 150	CNBt 150	1,5	1,1	7,5	3,3		40	39	38	36	32	25						1"1/2	1"1/4
CNB 200	CNBt 200	2	1,5	9,5	4		43	42,5	42	40	37,5	35	29					1"1/2	1"1/4
CNB 300	CNBt 300	3	2,2	12	4,6		49	48	47	46,5	46	43	38,5	25				1"1/2	1"1/4

ELETTROPOMPE AUTODESCANTI PER ASPIRAZIONI PROFONDE SELFPRIMING PUMPS FOR DEEP SUCTION



LIMITI D'IMPIEGO

- Temperatura liquido fino a 35°C
- Temperatura ambiente fino a 40°C
- Altezza d'aspirazione manometrica fino a 45 mt.
- Servizio continuo

MOTORE

- Motore elettrico ad induzione a 2 poli ($n = 2850 \text{ min}^{-1}$)
- Isolamento Classe F
- Protezione IP 44

MATERIALI

- Corpo pompa Ghisa
- Supporto motore Alluminio
- Girante Noryl
- Diffusore Noryl
- Eiettore Ghisa
- Flangia portanenna Acciaio Inox
- Albero motore Acciaio Inox
- Tenute meccaniche Ceramica/Carbone

OPERATING CONDITIONS

- Liquid temperature up to 35°C
- Ambient temperature up to 40°C
- Total suction lift up to 45 mt.
- Continuous duty

MOTOR

- Two-Pole induction motor ($n = 2850 \text{ min}^{-1}$)
- Insulation Class F
- Protection IP 44

MATERIALS

- Pump body Cast Iron
- Motor support Aluminium
- Impeller Noryl
- Diffuser Noryl
- Ejector Cast Iron
- Pump flange Stainless steel
- Shaft with rotor Stainless Steel
- Mechanical seal Carbon/Ceramic

La pompa a eiettore separato è sostanzialmente una centrifuga, con la possibilità di diventare una pompa jet autoadescente a profonda aspirazione, con l'applicazione dell'eiettore, nel pozzo, sulla parte finale del tubo di aspirazione. Il ricircolo dell'acqua che attraversa il venturi attrae l'acqua sottostante e la spinge attraverso il tubo di ritorno (aspirazione) creando una pressione sufficiente per portarla in superficie. Per queste applicazioni a profonda aspirazione è necessario il collegamento di due tubi: la mandata verso l'eiettore e lo scarico di ritorno (aspirazione), in questo caso il diametro del pozzo deve essere almeno di 4". Nel caso si debba applicare la pompa in un pozzo da 2" è necessario un eiettore "Jector" a chiusura ermetica sul pozzo, che funziona con solo il tubo di ritorno (aspirazione) sfruttando lo spazio che rimane fra esso e il pozzo di 2" come secondo tubo di ricircolo.

The separate ejector pump is basically a centrifuge with the possibility of becoming a self-priming jet pump with deep suction by fitting the ejector in the well onto the end of the suction pipe. Recirculation of water passing through the Venturi attracts water from below and pushes it through the return (suction) pipe creating enough pressure to take it up to the surface. For these deep suction applications two pipes need to be connected: the delivery pipe to the ejector and the return (suction) outlet, in this case the diameter of the well must be at least 4". If the pump has to go in a 2" well, a special ejector with an airtight lock on the well is necessary. It works with just the return (suction) pipe by exploiting the space remaining between itself and the 2" well as a second recirculation pipe.

TIPO - TYPE		POTENZA NOMINALE		AMPERE				Q = PORTATA - CAPACITY													
Monofase Single-phase	Trifase Three-phase	NOMINAL POWER P2		Monofase Single phase 1 x 230V	Trifase Three phase 3 x 400V	Tipo eiettore Ejector	Profon. aspiraz. m. Suction depth m.	0,18	0,36	0,6	0,9	1,2	1,5	1,8	2,1	3	3,6	Dimensioni Dimensions			
		HP	kW					3	6	10	15	20	25	30	35	50	60	DNA	DNM		
230V-50Hz	230/400V-50Hz							Prevalenza manometrica totale in m.C.A. - Total head in meters w.c.													
JAP 100	JAPt 100	1	0,75	5	2,5	P 20	15	38	36	32	29	27	24	20	15				1"1/4	1"	
							20	36	32	28	24	20	16								
							25	29	25	19	13	10									
							30	12	8												
							35	11	4												

ELETTROPOMPE AUTODESCANTI PER ASPIRAZIONI PROFONDE SELFPRIMING PUMPS FOR DEEP SUCTION

LIMITI D'IMPIEGO

- Temperatura liquido fino a 35°C
- Temperatura ambiente fino a 40°C
- Altezza d'aspirazione manometrica fino a 45 mt.
- Servizio continuo

MOTORE

- Motore elettrico ad induzione a 2 poli ($n = 2850 \text{ min}^{-1}$)
- Isolamento Classe F
- Protezione IP 44

MATERIALI

- Corpo pompa Ghisa
- Supporto motore Ghisa
- Girante Noryl
- Diffusore Noryl
- Eiettore Ghisa
- Albero motore Acciaio Inox
- Tenute meccaniche Ceramica/Carbone



OPERATING CONDITIONS

- Liquid temperature up to 35°C
- Ambient temperature up to 40°C
- Total suction lift up to 45 mt.
- Continuous duty

MOTOR

- Two-Pole induction motor ($n = 2850 \text{ min}^{-1}$)
- Insulation Class F
- Protection IP 44

MATERIALS

- Pump body Cast Iron
- Motor support Cast Iron
- Impeller Noryl
- Diffuser Noryl
- Ejector Cast Iron
- Shaft with rotor Stainless Steel
- Mechanical seal Carbon/Ceramic

La pompa a eiettore separato è sostanzialmente una centrifuga, con la possibilità di diventare una pompa jet autoadescante a profonda aspirazione, con l'applicazione dell'eiettore, nel pozzo, sulla parte finale del tubo di aspirazione. Il ricircolo dell'acqua che attraverso il venturi attrae l'acqua sottostante e la spinge attraverso il tubo di ritorno (aspirazione) creando una pressione sufficiente per portarla in superficie. Per queste applicazioni a profonda aspirazione è necessario il collegamento di due tubi: la mandata verso l'eiettore e lo scarico di ritorno (aspirazione), in questo caso il diametro del pozzo deve essere almeno di 4".

The separate ejector pump is basically a centrifuge with the possibility of becoming a self-priming jet pump with deep suction by fitting the ejector in the well onto the end of the suction pipe. Recirculation of water passing through the Venturi attracts water from below and pushes it through the return (suction) pipe creating enough pressure to take it up to the surface. For these deep suction applications two pipes need to be connected: the delivery pipe to the ejector and the return (suction) outlet, in this case the diameter of the well must be at least 4".

TIPO - TYPE		POTENZA NOMINALE NOMINAL POWER P2		AMPERE				Q = PORTATA - CAPACITY																	
Monofase Single-phase	Trifase Three-phase	HP	kW	Monofase Single phase	Trifase Three phase	Tipo eiettore	Profon. aspiraz. m.	m ³ /h	0,18	0,36	0,6	0,9	1,2	1,5	1,8	2,1	3	3,6	Dimensioni Dimensions						
230V-50Hz	230/400V-50Hz			1 x 230V	3 x 400V	Ejector	Suction depth m.	lt/1'	3	6	10	15	20	25	30	35	50	60	DNA	DNM					
JAP 150	JAPt 150	1,5	1,1	7	3	P 20	15									42	35	25	21	1"1/4	1"				
							20						50	37	30	21									
							25						45	34	27										
							35				49	41	20												
							40			48	40														
							50		49	43	20														
JAP 200	JAPt 200	2	1,5	9,3	4,2	P 20	15									46	35	30	1"1/4	1"					
							20						48	43	32	27									
							25					50	44	40	28	23									
							35						28	20											
							40			46	30														
							50		49	40															

ELETTROPOMPE CENTRIFUGHE MONOGIRANTI
SINGLE IMPELLER CENTRIFUGAL PUMPS



LIMITI D'IMPIEGO

- Temperatura liquido fino a 60°C
- Temperatura ambiente fino a 40°C
- Altezza d'aspirazione manometrica fino a 7 mt.
- Servizio continuo

MOTORE

- Motore elettrico ad induzione a 2 poli ($n = 2850 \text{ min}^{-1}$)
- Isolamento Classe F
- Protezione IP 44

MATERIALI

- Corpo pompa Ghisa
- Supporto motore Ghisa
- Girante Ottone
- Albero motore Acciaio Inox
- Tenute meccaniche Ceramica/Carbone

OPERATING CONDITIONS

- Liquid temperature up to 60°C
- Ambient temperature up to 40°C
- Total suction lift up to 7 mt.
- Continuous duty

MOTOR

- Two-Pole induction motor ($n = 2850 \text{ min}^{-1}$)
- Insulation Class F
- Protection IP 44

MATERIALS

- Pump body Cast Iron
- Motor Support Cast Iron
- Impeller Brass
- Shaft with rotor Stainless Steel
- Mechanical seal Carbon/Ceramic

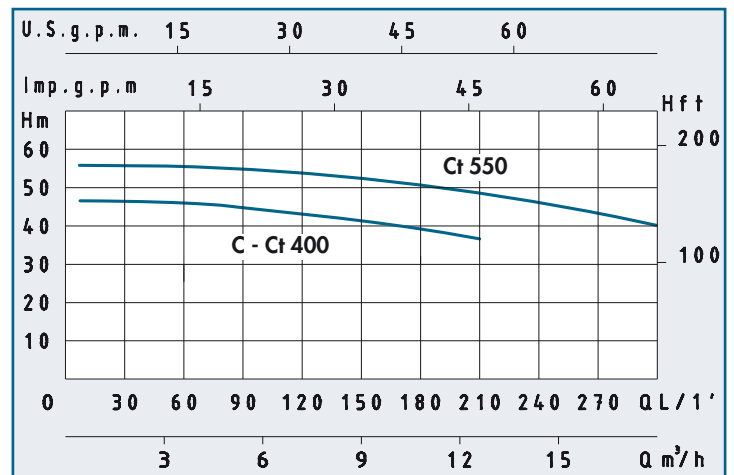
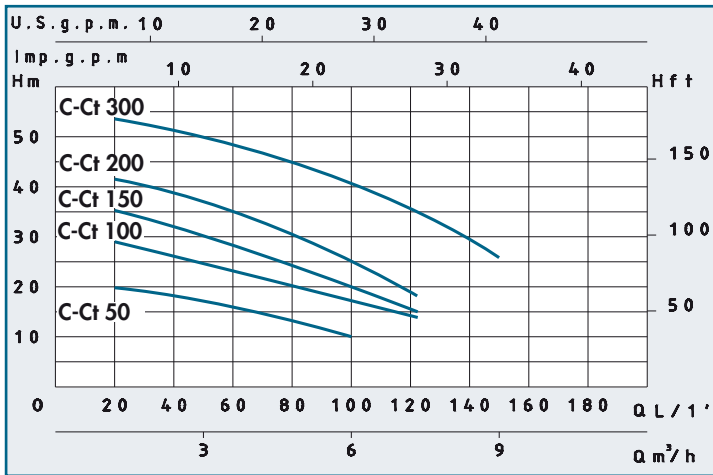

TIPO - TYPE		POTENZA NOMINALE NOMINAL POWER P2		AMPERE		Q = PORTATA - CAPACITY														
Monofase Single-phase	Trifase Three-phase	HP	kW	Monofase Single-phase	Trifase Three-phase	m³/h	0,6	1,2	2,7	3,6	5,4	6	7,5	9	12	18	Dimensioni Dimensions			
230V-50Hz	230/400V-50Hz			1 x 230V	3 x 400V	lt/1'	10	20	45	60	90	100	125	150	200	300	DNA	DNM		
C 50	Ct 50	0,5	0,37	2,8	1,2	H (m)	20	18	17	16	12	10						1"	1"	
C 100	Ct 100	1	0,75	5,5	2,3		29	28	26	23	20	18	14						1"	1"
C 150	Ct 150	1,5	1,1	7,5	3,1		36	33	30	28	24	22	15						1 1/4"	1"
C 200	Ct 200	2	1,5	9,3	4,2		43	42	37	35	27	25	18						1 1/4"	1"
C 300	Ct 300	3	2,2	14,5	5,9		54	53	50	48	45	42	36	26					1 1/4"	1"
C 400	Ct 400	4	3	21	7,6		47	46	45	44	43,5	43	42	41	38				2"	1 1/4"
	Ct 550	5,5	4		9,6		57	56	55,5	55	54,5	54	53	52	50	40			2"	1 1/4"

ELETTROPOMPE CENTRIFUGHE BIGIRANTI TWIN IMPELLER CENTRIFUGAL PUMPS

LIMITI D'IMPIEGO

- Pressione max. d'esercizio 6 bar (25/130A; 25/160C; 25/160B)
- Pressione max. d'esercizio 10 bar (32/210B; 32/210A; 32/215A)
- Pressione max. d'esercizio 16 bar (25/130A; 25/160C; 25/160B)
- Temperatura liquido fino a 35°C (25/130A; 25/160C; 25/160B)
- Temperatura liquido fino a 90°C (25/130A; 25/160C; 25/160B)
- Temperatura ambiente fino a 40°C
- Altezza d'aspirazione manometrica fino a 7 mt.
- Servizio continuo

MOTORE

- Motore elettrico ad induzione a 2 poli (n = 2850 min⁻¹)
- Isolamento Classe F
- Protezione IP 44

MATERIALI

- Corpo pompa Ghisa
- Supporto motore Ghisa
- Girante Ottone
- Albero motore Acciaio Inox
- Tenute meccaniche Ceramica/Grafite

OPERATING CONDITIONS

- Max. working pressure 6 bar (25/130A; 25/160C; 25/160B)
- Max. working pressure 10 bar (32/210B; 32/210A; 32/215A)
- Max. working pressure 16 bar (25/130A; 25/160C; 25/160B)
- Liquid temperature up to 35°C (25/130A; 25/160C; 25/160B)
- Liquid temperature up to 90°C (25/130A; 25/160C; 25/160B)
- Ambient temperature up to 40°C
- Total suction lift up to 7 mt.
- Continuous duty

MOTORS

- Two-Pole induction motor (n = 2850 min⁻¹)
- Insulation Class F
- Protection IP 44

MATERIALS

- Pump body Cast Iron
- Motor Support Cast Iron
- Impeller Brass
- Shaft with rotor Stainless Steel
- Mechanical seal Ceramic/Graphite



TIPO - TYPE		POTENZA NOMINALE NOMINAL POWER P2		AMPERE		Q = PORTATA - CAPACITY													
Monofase Single-phase	Trifase Three-phase	HP	kW	Monofase Single-phase	Trifase Three-phase	m ³ /h	0	1,5	3	6	9	12	15	18	24	30	Dimensioni Dimensions		
				1 x 230V	3 x 400V	lt/1'	0	25	50	100	150	200	250	300	400	500	DNA	DNM	
230V-50Hz	230/400V-50Hz					Prevalenza manometrica totale in m.C.A. - Total head in meters w.c.													
CB 25/130A	CBt 25/130A	1	0,75	5,5	2,5	44	41	37										1"	1"
CB 25/160C	CBt 25/160C	1,5	1,1	10	3,8	55	52	49	35									1"1/4	1"
CB 25/160B	CBt 25/160B	2	1,5	11	4,2	58	56	54	40									1"1/4	1"
	CBt 25/160A	3	2,2		5,2	64	62	60	54	45								1"1/4	1"
	CBt 25/180A	4	3		7	72	70	68	60	52	39							1"1/4	1"
	CBt 32/190C	3	2,2		5,2	64	62	60	54	45	42							1"1/2	1"1/4
	CBt 32/190B	4	3		7,5	73,5	72	69,5	63	55	43							1"1/2	1"1/4
	CBt 32/190A	5,5	4		9,3	88	86	84	77	68	56							1"1/2	1"1/4
	CBt 32/210D	5,5	4		9,3	79	78,8	78,5	75,5	70	62	50						2"	1"1/4
	CBt 32/210C	7,5	5,5		13	90	89,5	89	87	82,5	76	64	49					2"	1"1/4
	CBt 32/210B	10	7,5		16	105,5	105,3	105	102,5	98	91	82	68					2"	1"1/4
	CBt 32/210A	12,5	9,2		18,5	117	116,8	116,5	114,5	110	103	94	82					2"	1"1/4
	CBt 32/215A	15	11		21	120	119,8	119,5	117,5	112	105	96	84					2"	1"1/4
	CBt 40/180D	5,5	4		9,3	60	59,5	59	58	56,5	54	50	45	34				2"	1"1/2
	CBt 40/180C	7,5	5,5		13	71	70,9	70,7	70,5	69	67	63,5	60	50	35			2"	1"1/2
	CBt 40/180B	10	7,5		16	87	86	85,5	85	83	81	77,5	75	65	51			2"	1"1/2
	CBt 40/180A	12,5	9,2		18,5	93,5	93,4	93,3	93	92	90	87	82	71	58			2"	1"1/2
	CBt 40/200A	15	11		21	96	95,9	95,8	95,5	94,5	92,5	89,5	85,5	76,5	65			2"	1"1/2

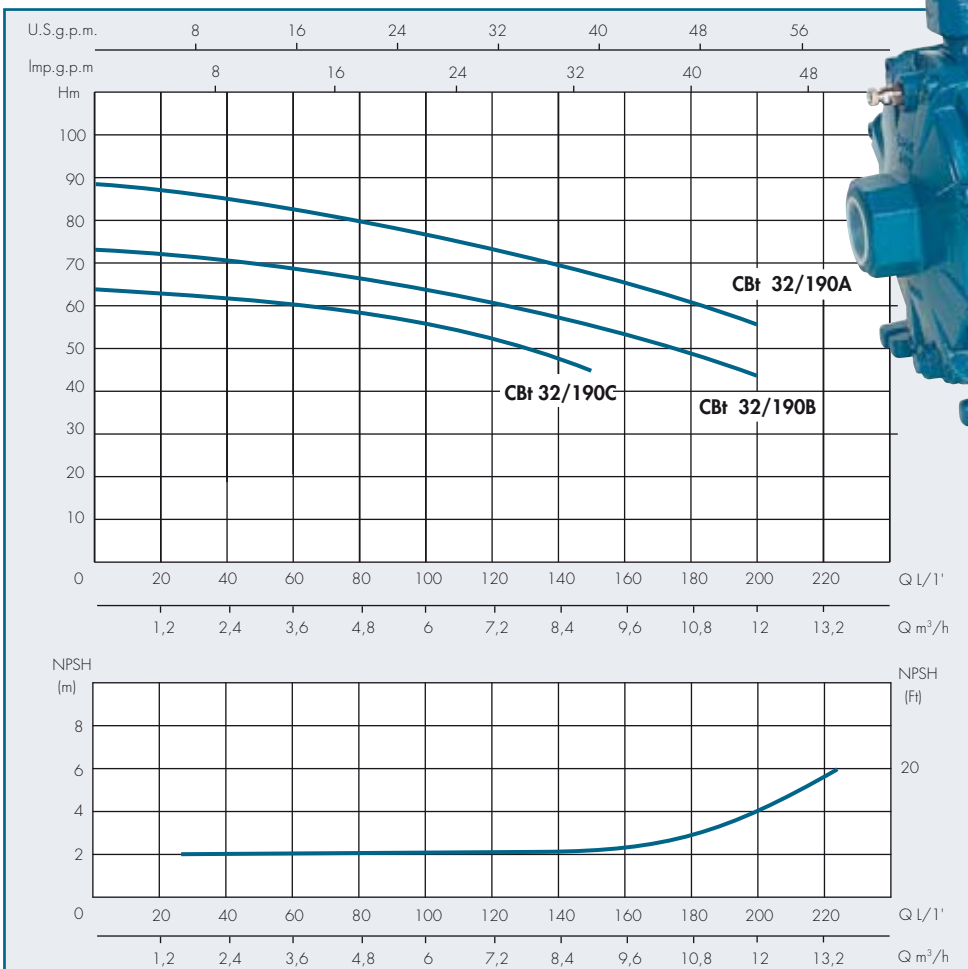
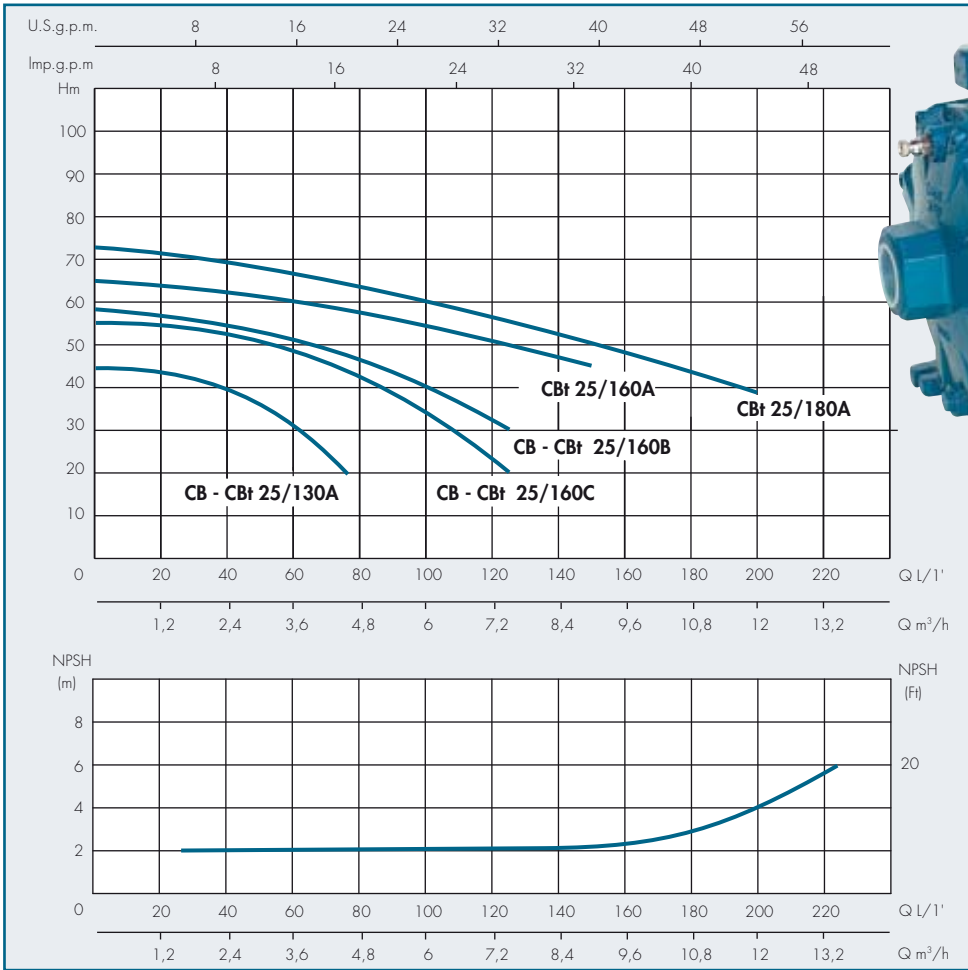

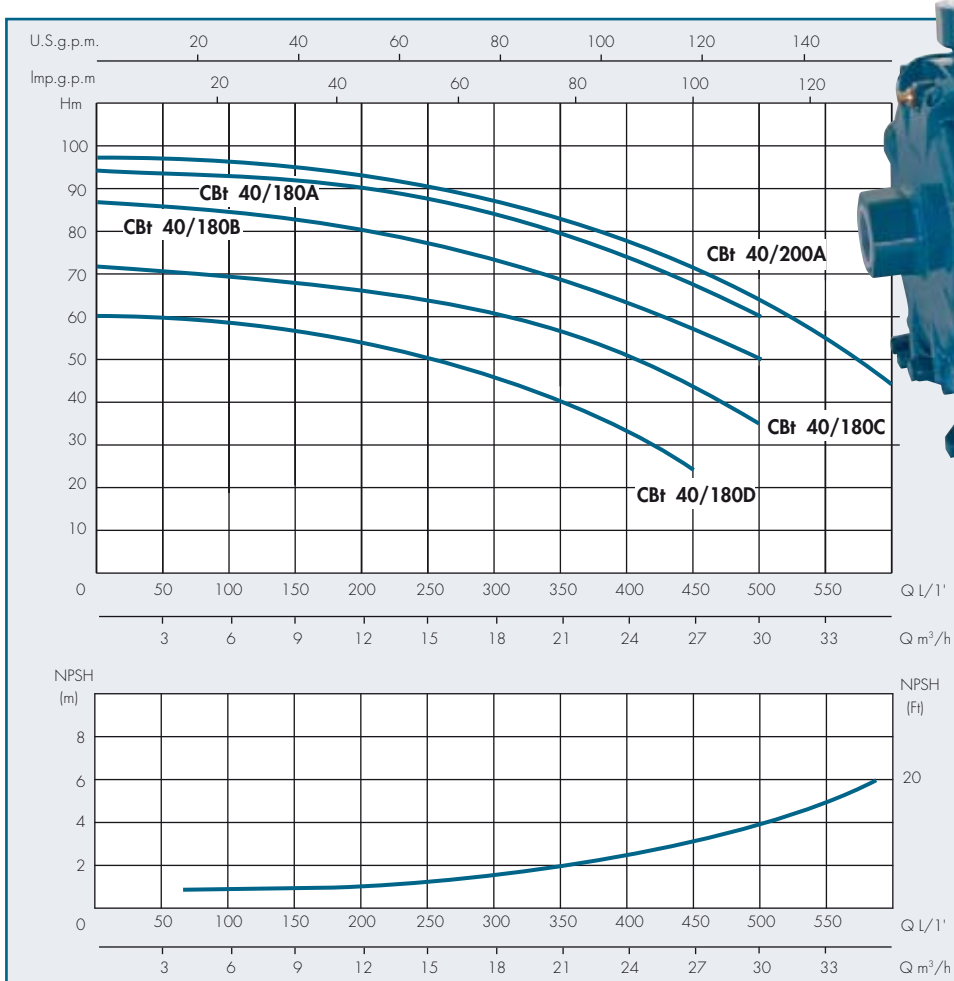
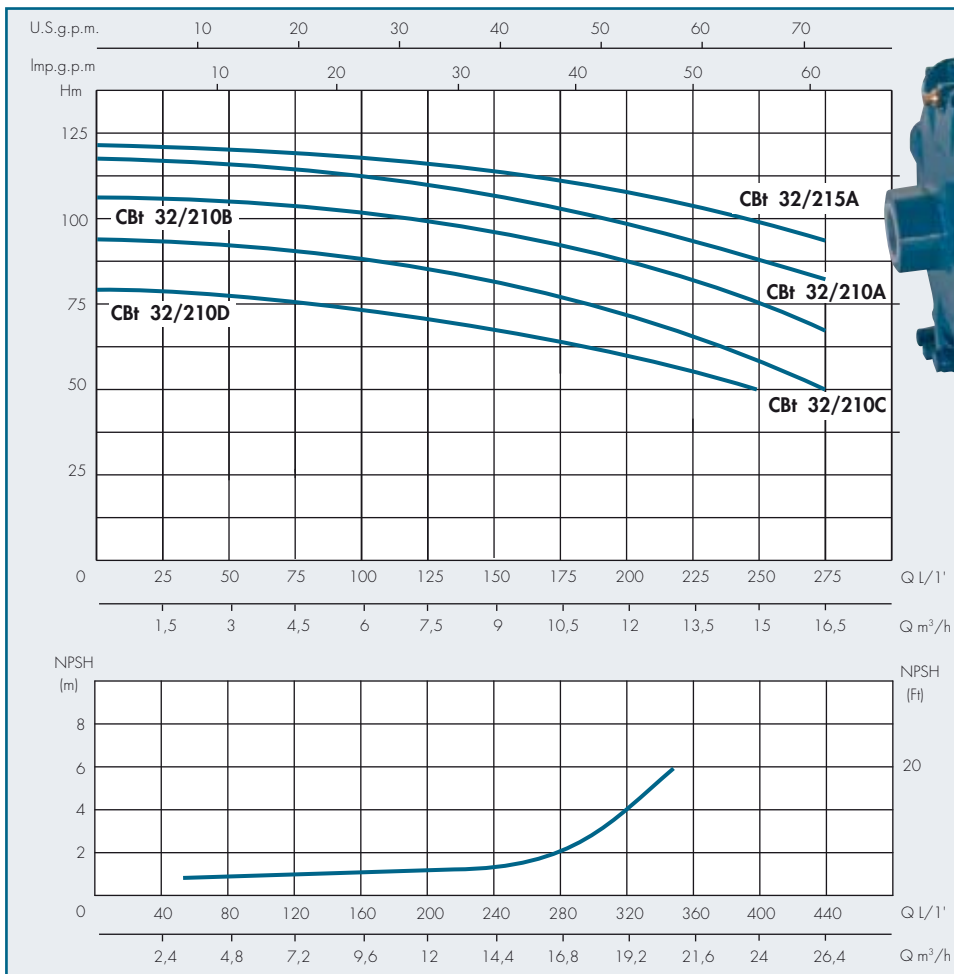

ELETTROPOMPE CENTRIFUGHE MONOGIRANTI SINGLE IMPELLER CENTRIFUGAL PUMPS

LIMITI D'IMPIEGO

- Pressione max. d'esercizio 10 bar
- Temperatura liquido fino a 90° C
- Temperatura ambiente fino a 40° C
- Altezza d'aspirazione manometrica fino a 7 mt.
- Servizio continuo

MOTORE

- Motore elettrico ad induzione a 2 poli (n = 2850 min⁻¹)
- Isolamento Classe F
- Protezione IP 44
- Esecuzione secondo IEC 34

MATERIALI

- Corpo pompa Ghisa
- Supporto motore Ghisa
- Girante Ghisa
- Albero motore Acciaio Inox
- Tenute meccaniche Ceramica/Grafite



OPERATING CONDITIONS

- Max. working pressure 10 bar
- Liquid temperature up to 90°C
- Ambient temperature up to 40°C
- Total suction lift up to 7 mt.
- Continuous duty

MOTOR

- Two-Pole induction motor (n = 2850 min⁻¹)
- Insulation Class F
- Protection IP 44
- IEC 34 construction standard

MATERIALS

- Pump body Cast Iron
- Motor Support Cast Iron
- Impeller Cast Iron
- Shaft with rotor Stainless Steel
- Mechanical seal Ceramic/Graphite

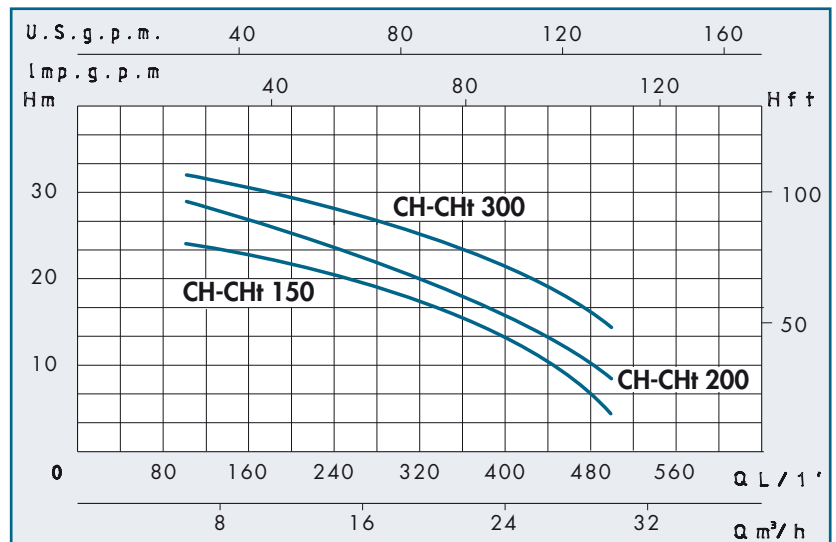

TIPO - TYPE		POTENZA NOMINALE NOMINAL POWER P2		AMPERE		Q = PORTATA - CAPACITY												
Monofase Single-phase	Trifase Three-phase	HP	kW	Monofase Single-phase	Trifase Three-phase	m³/h	0	6	9	12	15	18	21	24	27	30	Dimensioni Dimensions	
				1 x 230V	3 x 400V	lt/1'	0	100	150	200	250	300	350	400	450	500		
230V-50Hz	230/400V-50Hz					Prevalenza manometrica totale in m.C.A. - Total head in meters w.c.											DNA	DNM
CH 150	CHt 150	1,5	1,1	9,2	3,4	H (m)	24,5	24	23,5	22	20	18	15	12	8	4	2"	2"
CH 200	CHt 200	2	1,5	11,5	4,2		28,5	28	27	25,5	23	21,4	18,6	15,8	12	8	2"	2"
CH 300	CHt 300	3	2,2	13,6	5,3		32,5	32	31	29,5	27	26	23	20	17	14	2"	2"

ELETTROPOMPE CENTRIFUGHE MONOGIRANTI SINGLE IMPELLER CENTRIFUGAL PUMPS



LIMITI D'IMPIEGO

- Pressione max. d'esercizio 10 bar
- Temperatura liquido fino a 90° C
- Temperatura ambiente fino a 40° C
- Altezza d'aspirazione manometrica fino a 7 mt.
- Servizio continuo

MOTORE

- Motore elettrico ad induzione a 2 poli (n = 2850 min⁻¹)
- Isolamento Classe F
- Protezione IP 44
- Esecuzione secondo IEC 34

MATERIALI

- Corpo pompa Ghisa
- Supporto motore Ghisa
- Girante Ghisa
- Albero motore Acciaio Inox
- Tenute meccaniche Ceramica/Grafite

OPERATING CONDITIONS

- Max. working pressure 10 bar
- Liquid temperature up to 90°C
- Ambient temperature up to 40°C
- Total suction lift up to 7 mt.
- Continuous duty

MOTOR

- Two-Pole induction motor (n = 2850 min⁻¹)
- Insulation Class F
- Protection IP 44
- IEC 34 construction standard

MATERIALS

- Pump body Cast Iron
- Motor Support Cast Iron
- Impeller Cast Iron
- Shaft with rotor Stainless Steel
- Mechanical seal Ceramic/Graphite

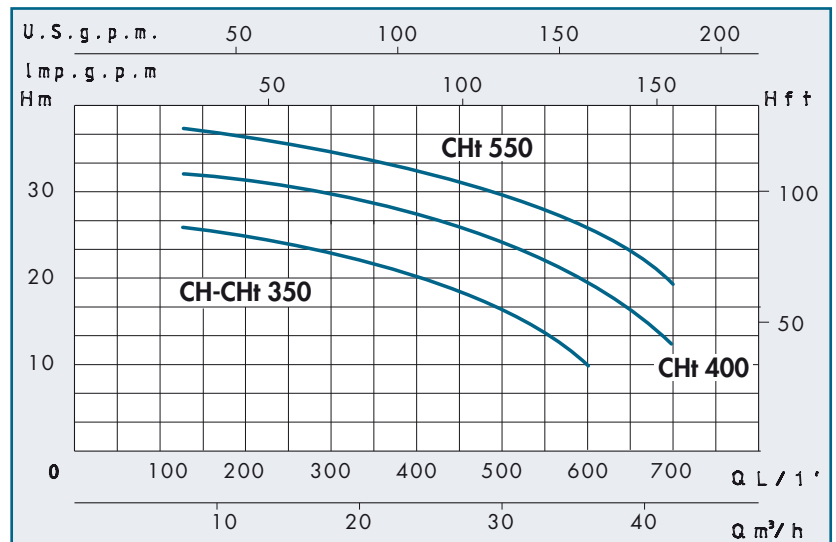

TIPO - TYPE		POTENZA NOMINALE NOMINAL POWER P2		AMPERE		Q = PORTATA - CAPACITY													
Monofase Single-phase	Trifase Three-phase	HP	kW	Monofase Single-phase	Trifase Three-phase	m³/h	0	6	9	12	15	18	24	30	36	42	Dimensioni Dimensions		
230V-50Hz	230/400V-50Hz			1 x 230V	3 x 400V	lt/1'	0	100	150	200	250	300	400	500	600	700			
CH 350	CHt 350	3	2,2	13,6	5,3	H (m)	26,5	26	25,5	25	24	23	20	16	11		3"	2"	
	CHt 400	4	3		7,6		32,5	32	31,8	31,6	30	29,8	27,7	23	19	13		3"	2"
	CHt 550	5,5	4		10		37,5	37	36,9	36,8	36	35,5	33	29,5	25	19		3"	2"

ELETTROPOMPE CENTRIFUGHE DI SCORRIMENTO CENTRIFUGAL IRRIGATION PUMPS



LIMITI D'IMPIEGO

- Pressione max. d'esercizio 6 bar
- Temperatura liquido fino a 60° C
- Temperatura ambiente fino a 40° C
- Altezza d'aspirazione manometrica fino a 7 mt.
- Servizio continuo

MOTORE

- Motore elettrico ad induzione a 2 poli (n = 2850 min⁻¹)
- Isolamento Classe F
- Protezione IP 44

MATERIALI

- Corpo pompa Ghisa
- Supporto motore Ghisa
- Girante Ghisa
- Albero motore Acciaio Inox
- Tenute meccaniche Ceramica/Carbone

OPERATING CONDITIONS

- Max. working pressure 6 bar
- Liquid temperature up to 60°C
- Ambient temperature up to 40°C
- Total suction lift up to 7 mt.
- Continuous duty

MOTOR

- Two-Pole induction motor (n = 2850 min⁻¹)
- Insulation Class F
- Protection IP 44

MATERIALS

- Pump body Cast Iron
- Motor Support Cast Iron
- Impeller Cast Iron
- Shaft with rotor Stainless Steel
- Mechanical seal Carbon/Ceramic

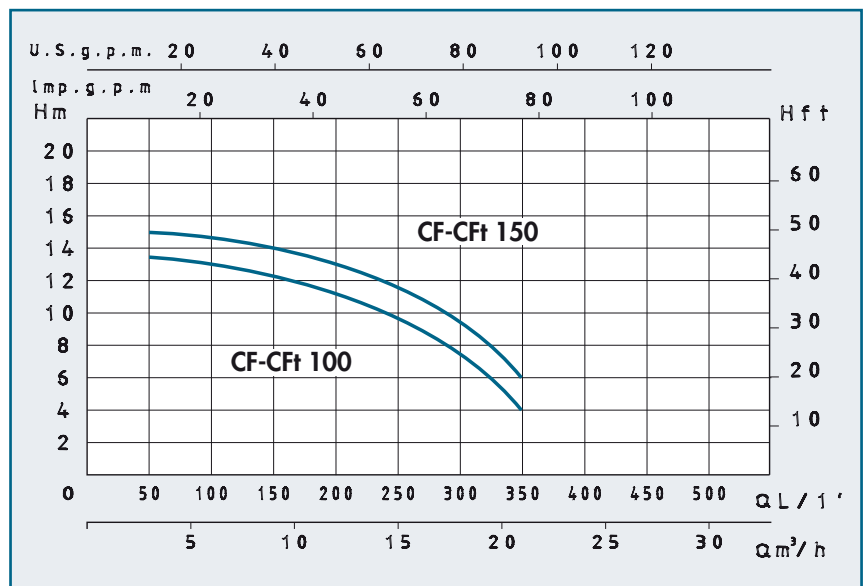

TIPO - TYPE		POTENZA NOMINALE NOMINAL POWER P2		AMPERE		Q = PORTATA - CAPACITY												
Monofase Single-phase	Trifase Three-phase	HP	kW	Monofase Single-phase	Trifase Three-phase	m³/h	3	6	9	12	15	18	21	24	27	30	Dimensioni Dimensions	
230V-50Hz	230/400V-50Hz			1 x 230V	3 x 400V	lt/1'	50	100	150	200	250	300	350	400	450	500	DNA	DNM
CF 100	CFt 100	1	0,75	5,3	2,2	H	13	12,8	12,2	11,5	10	7	4				2"	2"
CF 150	CFt 150	1,5	1,1	6,8	3	(m)	15	14,8	14,3	13,8	13	9	6				2"	2"

LIMITI D'IMPIEGO

- Pressione max. d'esercizio 10 bar
- Temperatura liquido fino a 90° C
- Temperatura ambiente fino a 40° C
- Altezza d'aspirazione manometrica fino a 7 mt.
- Servizio continuo

MOTORE

- Motore elettrico ad induzione a 2 poli (n = 2850 min⁻¹)
- Isolamento Classe F
- Protezione IP 44

MATERIALI

- Corpo pompa Ghisa
- Supporto motore Ghisa
- Girante Ghisa
- Girante Ghisa
- Albero motore Acciaio Inox
- Tenute meccaniche Ceramica/Grafite

OPERATING CONDITIONS

- Max. working pressure 10 bar
- Liquid temperature up to 90°C
- Ambient temperature up to 40°C
- Total suction lift up to 7 mt.
- Continuous duty

MOTOR

- Two-Pole induction motor (n = 2850 min⁻¹)
- Insulation Class F
- Protection IP 44

MATERIALS

- Pump body Cast Iron
- Motor Support Cast Iron
- Impeller Cast Iron
- Impeller Cast Iron
- Shaft with rotor Stainless Steel
- Mechanical seal Ceramic/Graphite

ELETTROPOMPE CENTRIFUGHE DI SCORRIMENTO CENTRIFUGAL IRRIGATION PUMPS

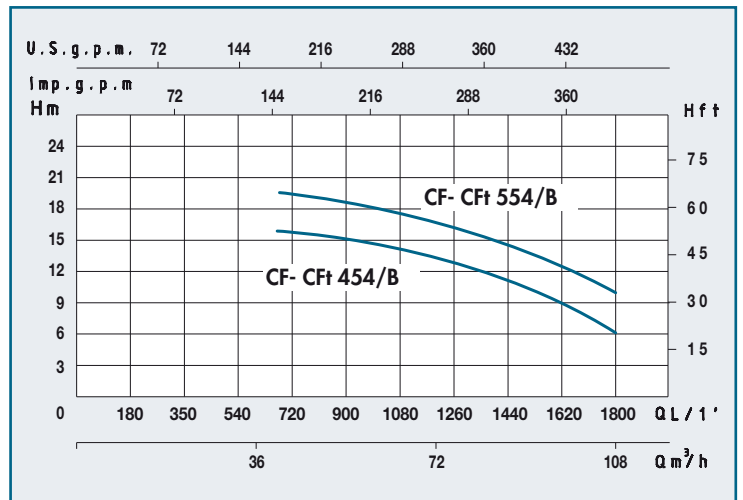
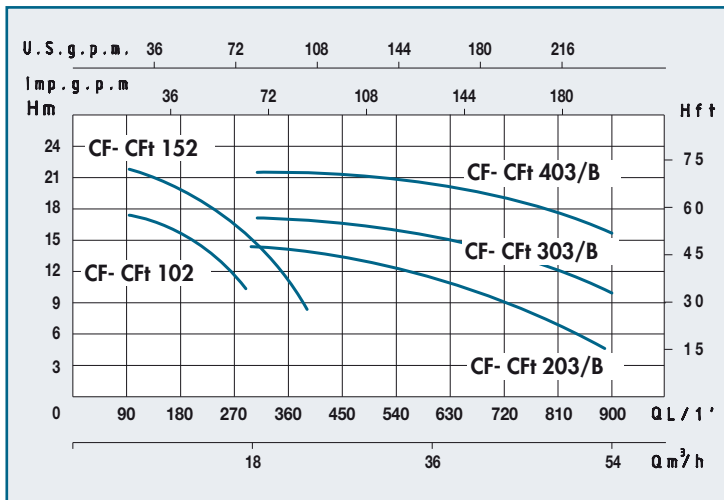

TIPO - TYPE		POTENZA NOMINALE NOMINAL POWER P2		AMPERE		Q = PORTATA - CAPACITY													
Monofase Single-phase	Trifase Three-phase	HP	kW	Monofase Single-phase	Trifase Three-phase	m³/h	6	12	18	24	30	42	54	72	96	108	Dimensioni Dimensions		
230V-50Hz	230/400V-50Hz			1 x 230V	3 x 400V	lt/1'	100	200	300	400	500	700	900	1200	1600	1800	DNA	DNM	
CF 102	CFt 102	1	0,75	5,5	2,5	H (m)	17,5	15,2	10,5									2"	2"
CF 152	CFt 152	1,5	1,1	8,5	3,5		21,5	19,2	15,3	8,8								2"	2"
CF 203/B	CFt 203/B	2	1,5	11	3,6				14	13,5	12,8	12	4,8					3"	3"
CF 303/B	CFt 303/B	3	2,2	15	5,5				17,4	17,3	16,4	14,2	10,2					3"	3"
CF 403/B	CFt 403/B	4	3	20	6,8				21,4	21,3	20,5	18,5	16	9				3"	3"
CF 454/B	CFt 454/B	4	3	20	6,8							15,3	14,8	12,5	8,5	6		4"	4"
CF 554/B	CFt 554/B	5,5	4	30	9							18,3	17,9	16	12	10		4"	4"

ELETTROPOMPE CENTRIFUGHE MONOBLOCCO
MONOBLOCK CENTRIFUGAL PUMPS

TIPO TYPE	POTENZA NOMINALE NOMINAL POWER P2		AMPERE	Q = PORTATA - CAPACITY										
	HP	kW	Trifase Three-phase	0	6	7,5	9	12	15	18	21	24	27	
			3 x 400V	0	100	125	150	200	250	300	350	400	450	
Prevalenza manometrica totale in m.C.A. - Total head in meters w.c.														
CN 32-160 C	2	1,5	4,8		25,5	25,3	25	24	23	21,5	20	18	15,5	
CN 32-160 B	3	2,2	5,7		28,8	28,5	28	27	26	24,5	23	21,5	18,5	
CN 32-160 A	4	3	7		36,5	36	35,5	34,5	33	31,5	30	28,5	26	
CN 32-200 C	5,5	4	8,8		40,7	40,5	40	39,5	39	38	36,5	35	33	
CN 32-200 B	7,5	5,5	14		55,7	55,5	55	54,5	54	53	51,5	50	48	
CN 32-200 A	10	7,5	15		60,7	60,5	60	59,5	58,5	57	55,5	54	52	
CN 32-250 C	12,5	9,2	18,5			70	69,5	68,5	67,5	66	64,5	62,5	59,5	
CN 32-250 B	15	11	21,5			81	80,5	79,5	78,5	77	75,5	73,5	71	
CN 32-250 A	20	15	25			90,5	90	89,5	89	87,5	86	84	81,5	
CN 40-160 B	4	3	7,5				32,7	32,5	32,3	32	31,5	30,5	29,5	
CN 40-160 A	5,5	4	8,8				36,2	36	35,8	35,5	35	34	33	
CN 40-200 B	7,5	5,5	14				46,5	46	45,5	45	44,5	43,5	42,5	
CN 40-200 A	10	7,5	18				56	55,5	55	54,5	54	53	52	
CN 40-250 B	15	11	22,5				74	73,9	73,8	73,7	73,5	73	72	
CN 40-250 A	20	15	29				91,5	91,4	91,3	91,2	91	90,5	90	
CN 50-160 D	4	3	7,5									25	24,5	24
CN 50-160 C	5,5	4	8,8									29,5	29,2	28,8
CN 50-160 B	7,5	5,5	13,2									37	36,8	36,5
CN 50-160 A	10	7,5	15									40	39,8	39,5
CN 50-200 C	12,5	9,2	18,5										48,7	48,5
CN 50-200 B	15	11	21										52,7	52,5
CN 50-200 A	20	15	28										64,5	64
CN 50-250 C	20	15	32											71,3
CN 50-250 B	25	18,5	36,5											80,8
CN 50-250 A	30	22,5	43											90
CN 65-160 E	7,5	5,5	13,2											
CN 65-160 D	10	7,5	16											
CN 65-160 C	12,5	9,2	18,5											
CN 65-160 B	15	11	21											
CN 65-160 A	20	15	26											
CN 65-200 C	20	15	32											
CN 65-200 B	25	18,5	36,5											
CN 65-200 A	30	22,5	43											
CN 65-250 B	40	30	54											
CN 65-250 A	50	37	62											
CN 80-160 D	15	11	20,5											
CN 80-160 C	20	15	24											
CN 80-160 B	25	18,5	30											
CN 80-160 A	30	22,5	35											
CN 80-200 B	40	30	54											
CN 80-200 A	50	37	62											

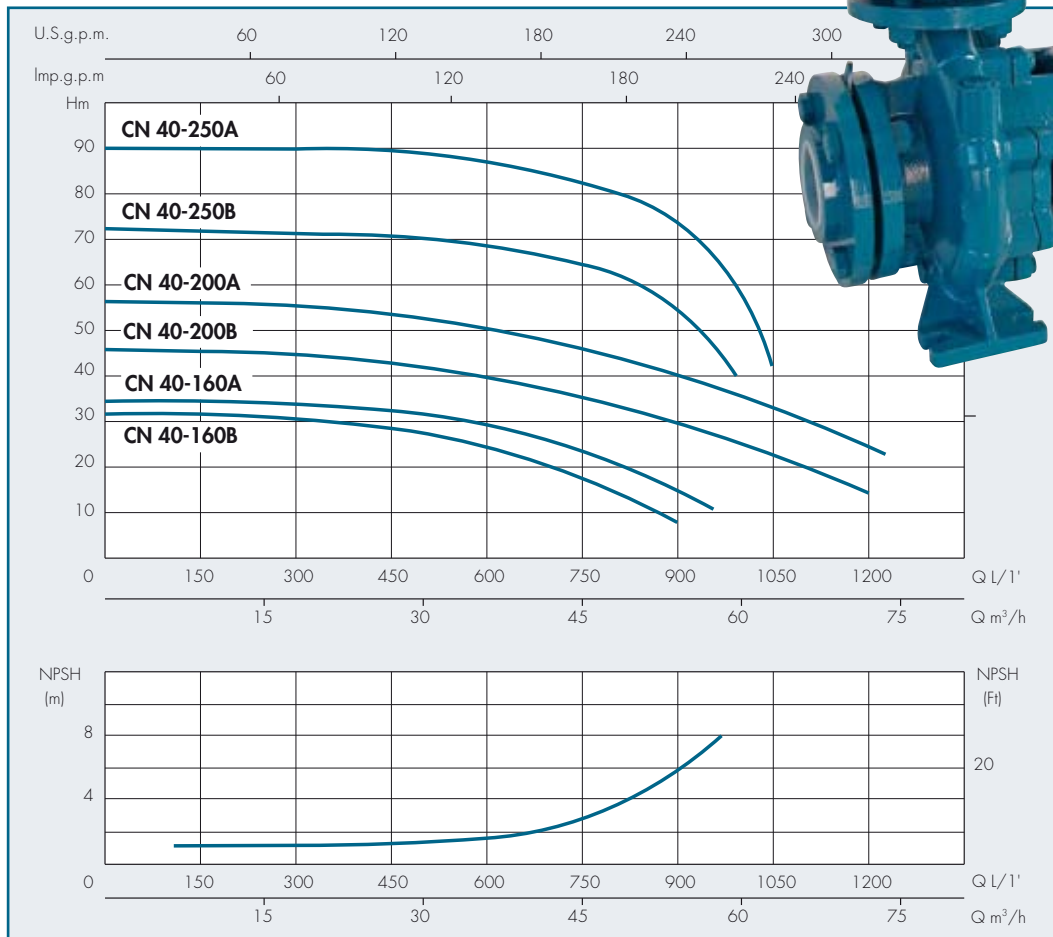
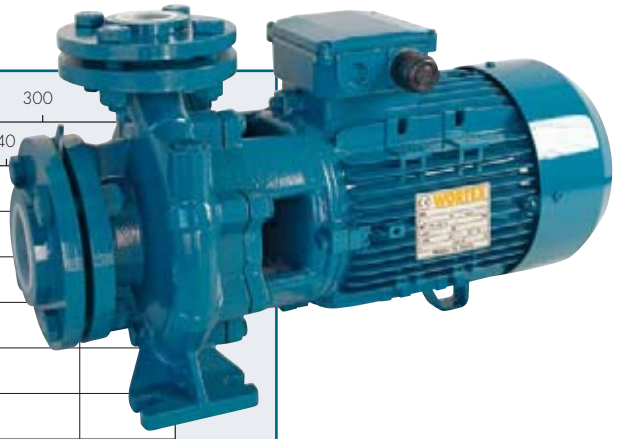
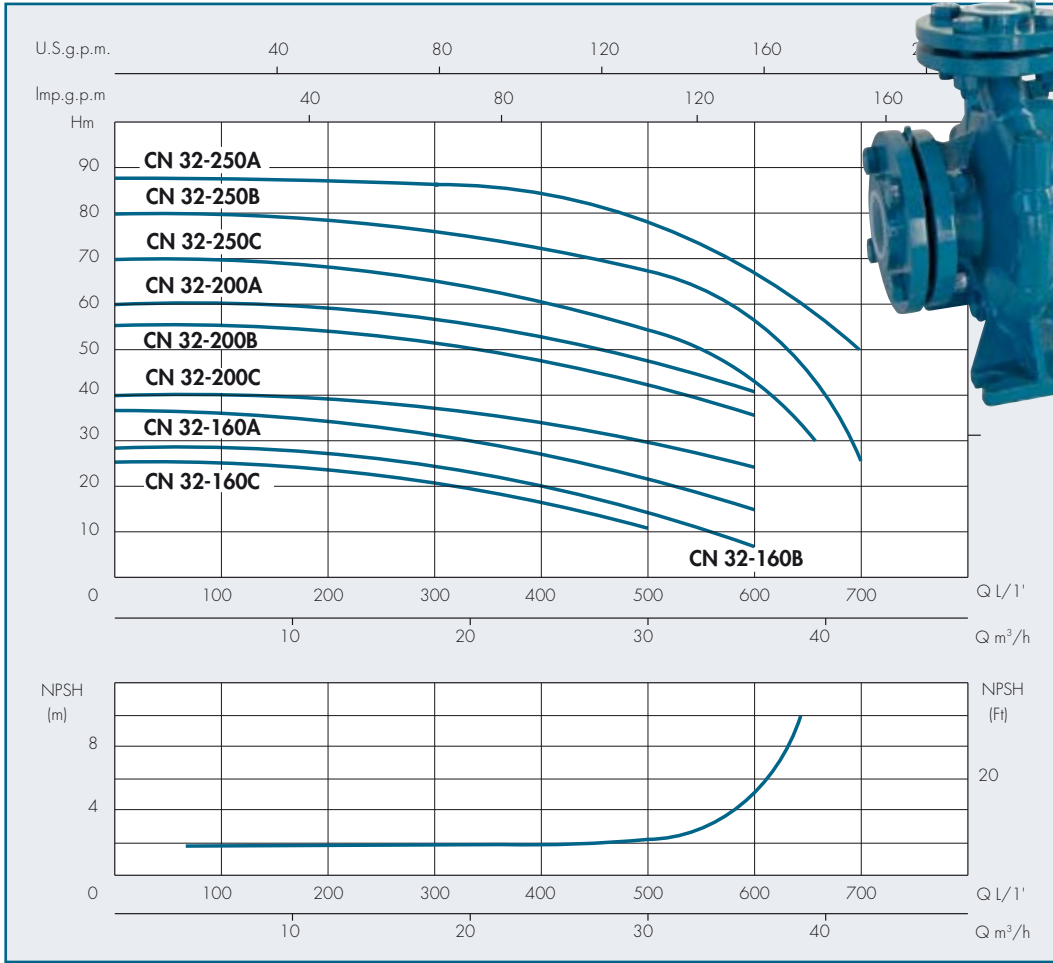

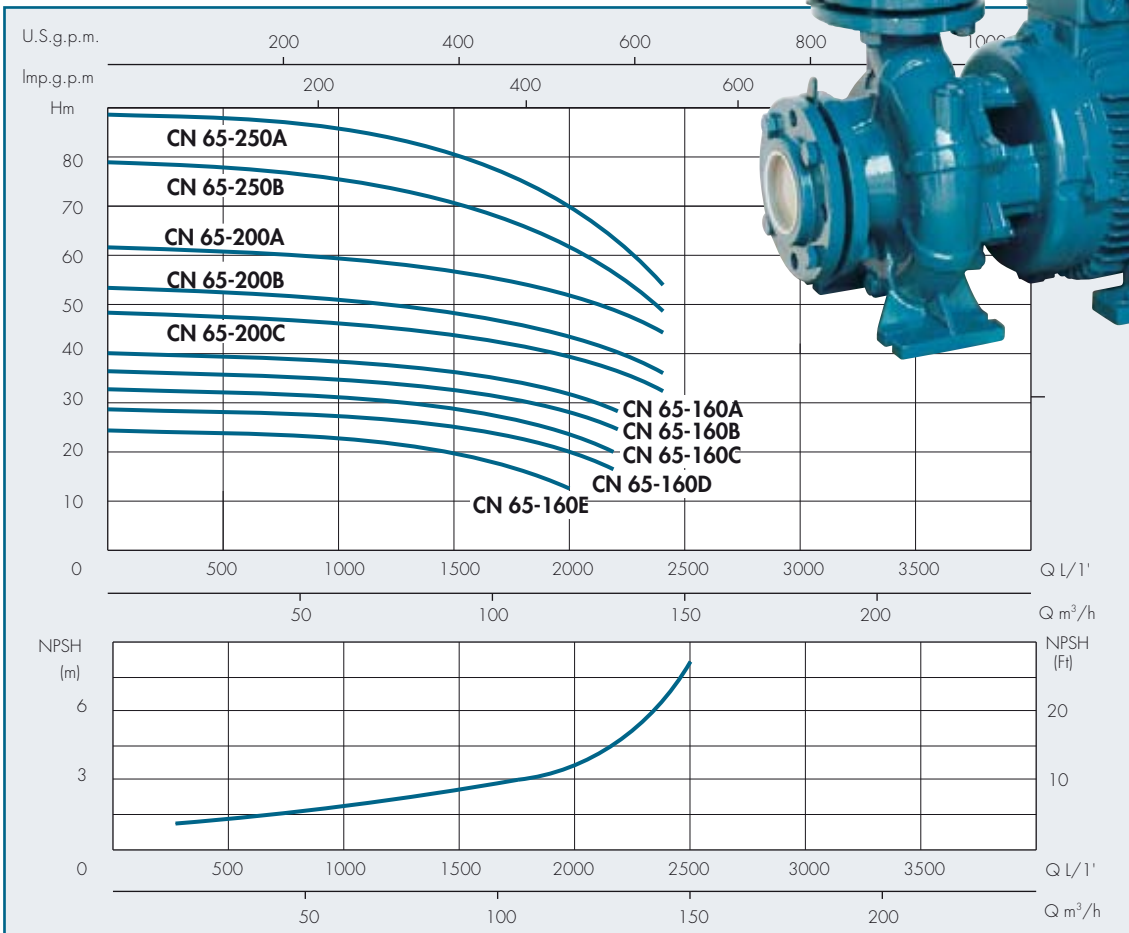
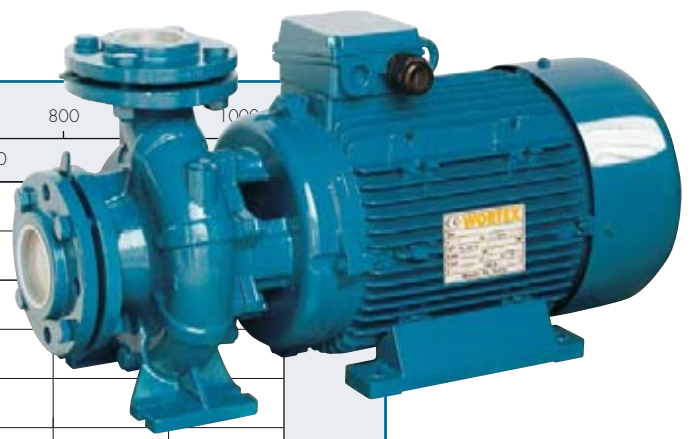
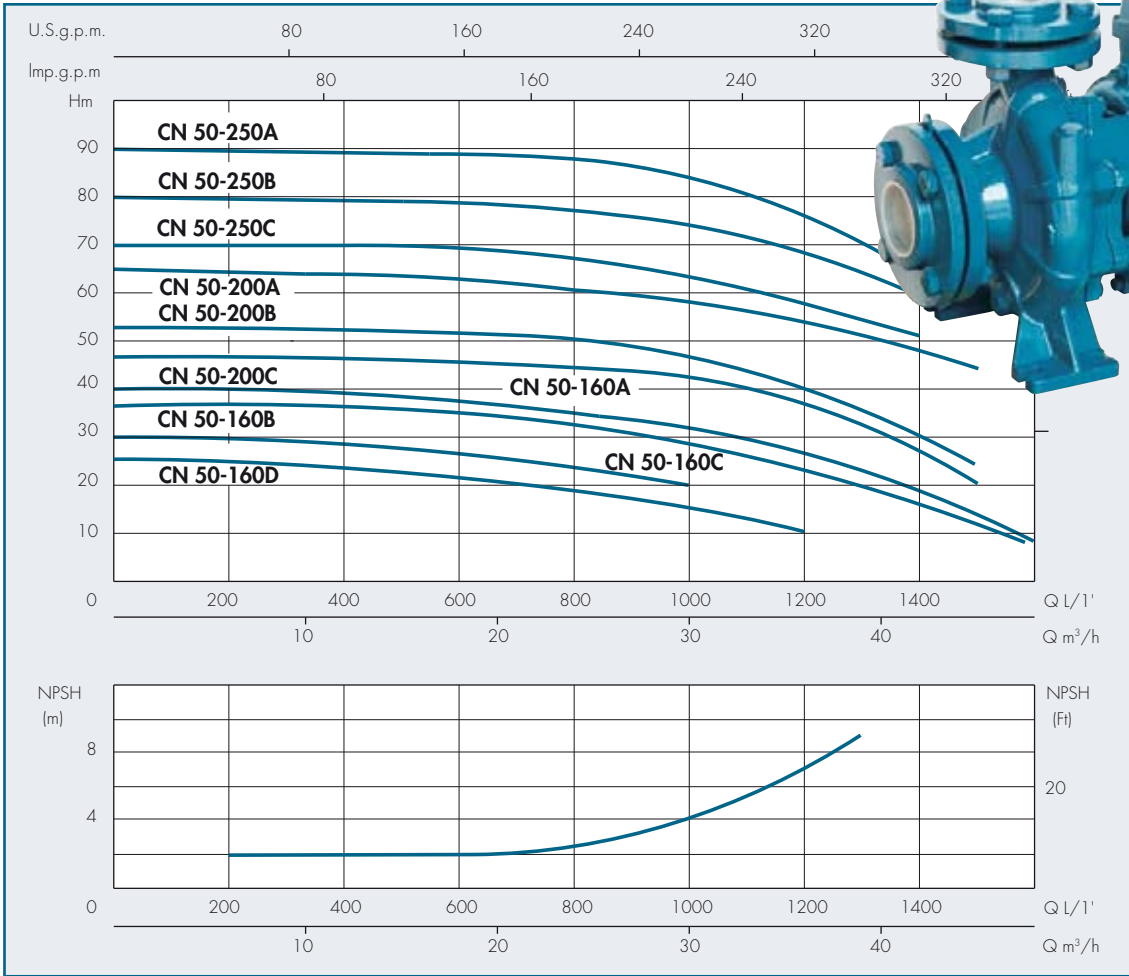

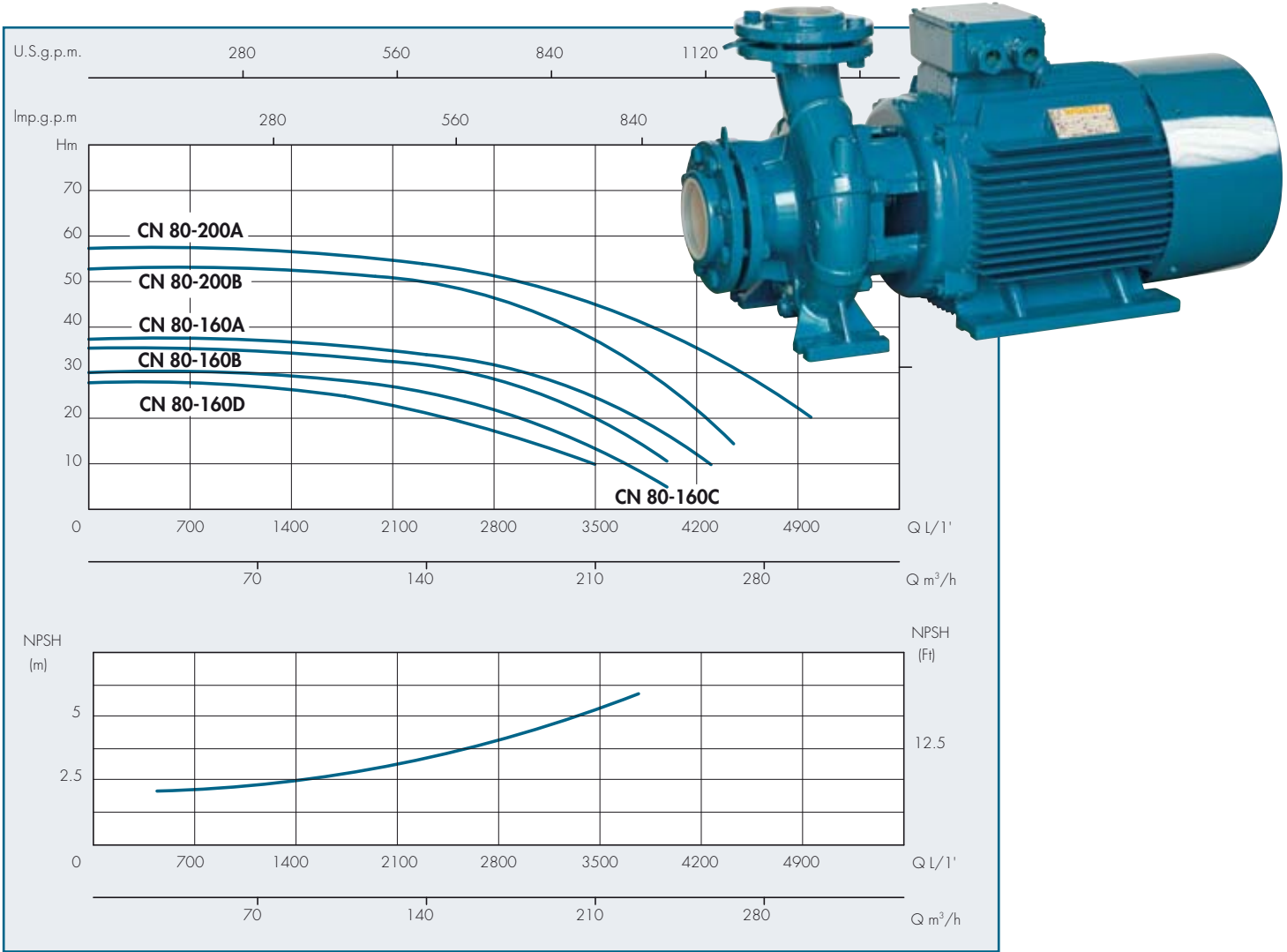

LIMITI D'IMPIEGO

- Pressione max. d'esercizio 10 bar
- Temperatura liquido fino a 90° C
- Temperatura ambiente fino a 40° C
- Altezza d'aspirazione manometrica fino a 7 mt.
- Servizio continuo

MOTORE

- Motore elettrico ad induzione a 2 poli (n = 2850 min⁻¹)
- Isolamento Classe F
- Protezione IP 44
- Esecuzione secondo IEC 34

MATERIALI

- Corpo pompa in Ghisa, dimensionato secondo le norme DIN 24255 - NF E 44-III UNI 7467, con bocche di aspirazione e di mandata flangiante (secondo le norme UNI 2236 PN 10), con controflange del tipo filettato;
- Supporto corpo pompa-motore in ghisa;
- Girante in ghisa;
- Albero in acciaio inossidabile;
- Tenuta meccanica in Ceramica/Grafite;

OPERATING CONDITIONS

- Max. working pressure 10 bar
- Liquid temperature up to 90°C
- Ambient temperature up to 40°C
- Total suction lift up to 7 mt.
- Continuous duty

MOTOR

- Two-Pole induction motor (n = 2850 min⁻¹)
- Insulation Class F
- Protection IP 44
- IEC 34 construction standard

MATERIALS

- Pump body in Cast Iron, dimensioned to DIN 24255 - NF E 44-III - UNI 7467 standards, with flanged inlet and delivery openings (to UNI 2238 PN 10 standards) and threaded counter-flanges;
- Pump body-motor support in cast iron;
- Impeller in cast iron;
- Shaft in stainless steel;
- Mechanical Seal in Carbon/Graphite;

FLANGE - FLANGES

DIMENSIONI mm - DIMENSIONS mm				
DN	DE	K	fori - holes	
			n°	∅
32	140	100	4	18
40	150	110	4	18
50	165	125	4	18
65	185	145	4	18
80	200	160	4	18
100	220	180	8	18

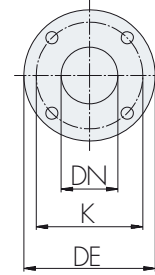
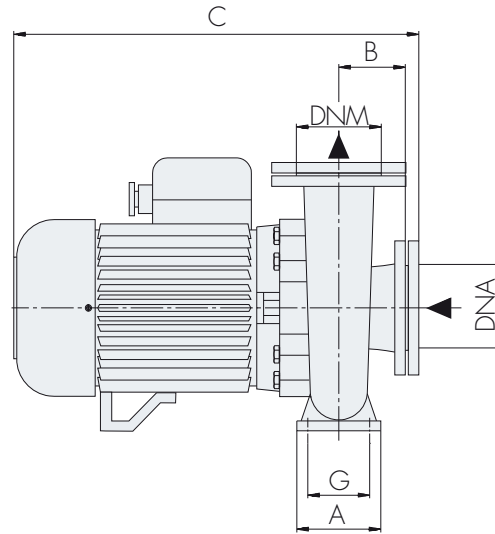
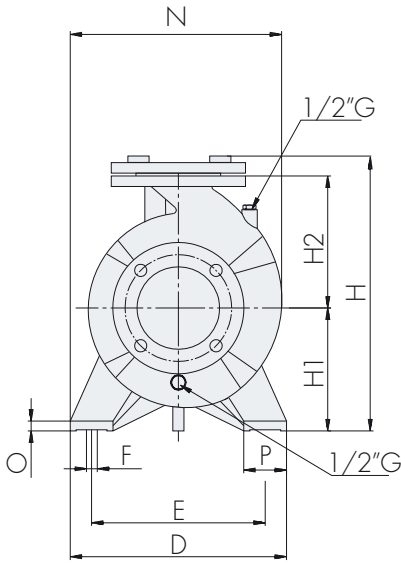

DIMENSIONI E PESI - DIMENSIONS AND WEIGHTS

TIPO TYPE	DIMENSIONI mm - DIMENSIONS mm															Dimensioni Dimensions mm			Peso Weight Kg
	A	B	C	D	E	F	G	H	H1	H2	N	O	P	DNA	DNM	P	L	H	
CN 32-160 C	100	80	480	240	190	15	70	322	132	160	240	13,5	50	50	32	250	520	360	36
CN 32-160 B	100	80	480	240	190	15	70	322	132	160	240	13,5	50	50	32	250	520	360	39
CN 32-160 A	100	80	510	240	190	15	70	322	132	160	240	13,5	50	50	32	250	520	360	42
CN 32-200 C	100	80	550	240	190	15	70	370	160	180	273	15	50	50	32	300	660	390	52
CN 32-200 B	100	80	630	240	190	15	70	370	160	180	273	15	50	50	32	300	660	390	63
CN 32-200 A	100	80	630	240	190	15	70	370	160	180	273	15	50	50	32	300	660	390	69
CN 32-250 C	125	100	745	320	250	15	95	445	180	225	335	18	65	50	32	355	790	455	83
CN 32-250 B	125	100	745	320	250	15	95	445	180	225	335	18	65	50	32	355	790	455	90
CN 32-250 A	125	100	745	320	250	15	95	445	180	225	335	18	65	50	32	355	790	455	120
CN 40-160 B	100	80	550	240	190	15	70	322	132	160	240	15	50	65	40	250	560	370	47
CN 40-160 A	100	80	550	240	190	15	70	322	132	160	240	15	50	65	40	250	560	370	50
CN 40-200 B	100	100	640	265	212	15	70	370	160	180	281	15	50	65	40	300	660	390	65
CN 40-200 A	100	100	640	265	212	15	70	370	160	180	281	15	50	65	40	300	660	390	71
CN 40-250 B	125	100	745	320	250	15	95	435	180	225	335	18	65	65	40	355	790	455	91
CN 40-250 A	125	100	745	320	250	15	95	435	180	225	335	18	65	65	40	355	790	455	121
CN 50-160 D	100	100	570	265	212	15	70	372	160	180	268	15	50	65	50	300	660	390	50
CN 50-160 C	100	100	570	265	212	15	70	372	160	180	268	15	50	65	50	300	660	390	60
CN 50-160 B	100	100	650	265	212	15	70	372	160	180	268	15	50	65	50	300	660	390	65
CN 50-160 A	100	100	650	265	212	15	70	372	160	180	268	15	50	65	50	300	660	390	71
CN 50-200 C	100	100	745	265	212	15	70	425	160	200	335	18	50	65	50	355	790	455	82
CN 50-200 B	100	100	745	265	212	15	70	425	160	200	335	18	50	65	50	355	790	455	89
CN 50-200 A	100	100	745	265	212	15	70	425	160	200	335	18	50	65	50	355	790	455	122
CN 50-250 C	125	100	750	320	250	15	95	435	180	225	340	18	65	65	50	355	790	455	125
CN 50-250 B	125	100	795	320	250	15	95	435	180	225	340	18	65	65	50	355	790	455	140
CN 50-250 A	125	100	825	320	250	15	95	455	180	225	360	18	65	65	50	380	850	465	149
CN 65-160 E	125	100	610	280	212	15	95	395	160	200	295	18	65	80	65	355	790	455	70
CN 65-160 D	125	100	610	280	212	15	95	395	160	200	295	18	65	80	65	355	790	455	80
CN 65-160 C	125	100	750	280	212	15	95	425	160	200	340	18	65	80	65	355	790	455	84
CN 65-160 B	125	100	750	280	212	15	95	425	160	200	340	18	65	80	65	355	790	455	90
CN 65-160 A	125	100	750	280	212	15	95	425	160	200	340	18	65	80	65	355	790	455	120
CN 65-200 C	125	100	745	320	250	15	95	445	180	225	335	18	65	80	65	355	790	455	122
CN 65-200 B	125	100	790	320	250	15	95	445	180	225	335	18	65	80	65	355	790	455	138
CN 65-200 A	125	100	825	320	250	15	95	455	180	225	360	18	65	80	65	380	850	465	148
CN 65-250 B	160	100	825	360	280	18	120	485	200	250	370	18	85	80	65	380	920	485	235
CN 65-250 A	160	100	825	360	280	18	120	485	200	250	370	18	85	80	65	380	920	485	250
CN 80-160 D	125	125	790	320	250	15	95	445	180	225	350	18	65	100	80	380	850	465	99
CN 80-160 C	125	125	790	320	250	15	95	445	180	225	350	18	65	100	80	380	850	465	129
CN 80-160 B	125	125	835	320	250	15	95	445	180	225	350	18	65	100	80	380	850	465	143
CN 80-160 A	125	125	870	320	250	15	95	445	180	225	360	18	65	100	80	380	920	485	152
CN 80-200 B	125	125	900	345	280	15	95	470	180	250	360	18	65	100	80	380	920	485	233
CN 80-200 A	125	125	900	345	280	15	95	470	180	250	360	18	65	100	80	380	920	485	247

ELETTROPOMPE AUTODESCANTI JET INOX SELFPRIMING JET INOX PUMPS

LIMITI D'IMPIEGO

- Pressione max. d'esercizio 6 bar
- Pressione max. d'esercizio 8 bar (130-160)
- Temperatura liquido fino a 35° C
- Temperatura ambiente fino a 40° C
- Altezza d'aspirazione manometrica fino a 8 mt.
- Servizio continuo

MOTORE

- Motore elettrico ad induzione a 2 poli (n = 2850 min⁻¹)
- Isolamento Classe F
- Protezione IP 44

MATERIALI

- Corpo pompa Acciaio Inox
- Supporto motore Alluminio
- Girante Noryl
- Girante Acciaio Inox (130-160)
- Diffusore Noryl
- Flangia portatenuta Acciaio Inox
- Albero motore Acciaio Inox
- Tenute meccaniche Ceramica/Carbone

OPERATING CONDITIONS

- Max. working pressure 6 bar
- Max. working pressure 8 bar (130-160)
- Liquid temperature up to 35°C
- Ambient temperature up to 40°C
- Total suction lift up to 8 mt.
- Continuous duty

MOTOR

- Two-Pole induction motor (n = 2850 min⁻¹)
- Insulation Class F
- Protection IP 44

MATERIALS

- Pump body Stainless Steel
- Motor Support Aluminium
- Impeller Noryl
- Impeller Stainless Steel (130-160)
- Diffuser Noryl
- Pump flange Stainless Steel
- Shaft with rotor Stainless Steel
- Mechanical seal Carbon/Ceramic



80/100



130/160

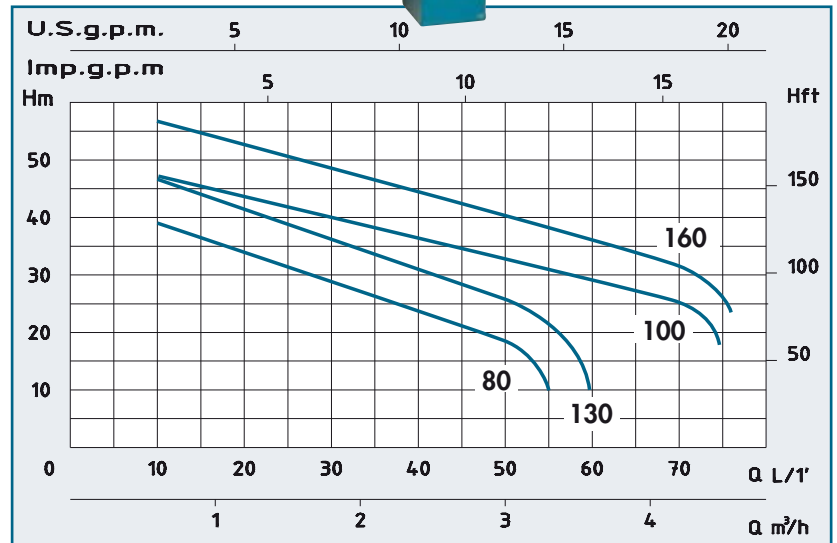

TIPO - TYPE		POTENZA NOMINALE NOMINAL POWER P2		AMPERE		Q = PORTATA - CAPACITY													
Monofase Single-phase	Trifase Three-phase	HP	kW	Monofase Single-phase	Trifase Three-phase	m³/h	0,6	0,9	1,2	1,5	1,8	2,1	2,4	2,7	3	3,6	3,6	Dimensionsi Dimensions	
230V-50Hz	230/400V-50Hz			1 x 230V	3 x 400V	lt/1'	10	15	20	25	30	35	40	45	50	60	DNA	DNM	
JX 80	JXt 80	0,8	0,6	3,8	1,9	H (m)	38	36	34	32	29	27	24	22	19			1"	1"
JX 100	JXt 100	1	0,75	5	2,5		46	43	40	38	35	32	30	29	26			1"	1"

TIPO - TYPE		POTENZA NOMINALE NOMINAL POWER P2		AMPERE		Q = PORTATA - CAPACITY												
Monofase Single-phase	Trifase Three-phase	HP	kW	Monofase Single-phase	Trifase Three-phase	m³/h	0,6	0,9	1,2	1,5	1,8	2,1	2,4	3	3,6	4,2	Dimensionsi Dimensions	
230V-50Hz	230/400V-50Hz			1 x 230V	3 x 400V	lt/1'	10	15	20	25	30	35	40	50	60	70	DNA	DNM
JX 130	JXt 130	1,3	1	5,8	2,8	H (m)	47	45	44	41	39	37	35	32	28	26	1"	1"
JX 160	JXt 160	1,6	1,1	7,5	3,5		56	53	50	48	46	44	42	36	34	32	1"1/4	1"

ELETTROPOMPA CENTRIFUGA AUTOADESCANTE MULTISTADIO CENTRIFUGAL SELFPRIMING MULTISTAGE PUMP



103



135



LIMITI D'IMPIEGO

- Pressione max. d'esercizio 6 bar
- Pressione max. d'esercizio 8 bar (135)
- Temperatura liquido fino a 35° C
- Temperatura ambiente fino a 40° C
- Altezza d'aspirazione manometrica fino a 8 mt.
- Servizio continuo

MOTORE

- Motore elettrico ad induzione a 2 poli ($n = 2850 \text{ min}^{-1}$)
- Isolamento Classe F
- Protezione IP 44

MATERIALI

- Corpo pompa: Acciaio Inox
- Supporto motore: Alluminio
- Girante: Noryl
- Diffusore Noryl
- Flangia portatenuta: Acciaio Inox
- Albero motore: Acciaio Inox
- Tenute meccaniche: Ceramica/Carbone

OPERATING CONDITIONS

- Max. working pressure 6 bar
- Max. working pressure 8 bar (135)
- Liquid temperature up to 35°C
- Ambient temperature up to 40°C
- Total suction lift up to 8 mt.
- Continuous duty

MOTOR

- Two-Pole induction motor ($n = 2850 \text{ min}^{-1}$)
- Insulation Class F
- Protection IP 44

MATERIALS

- Pump body: Stainless Steel
- Motor Support: Aluminium
- Impeller: Noryl
- Diffuser Noryl
- Pump flange: Stainless Steel
- Shaft with rotor: Stainless Steel
- Mechanical seal: Carbon/Ceramic

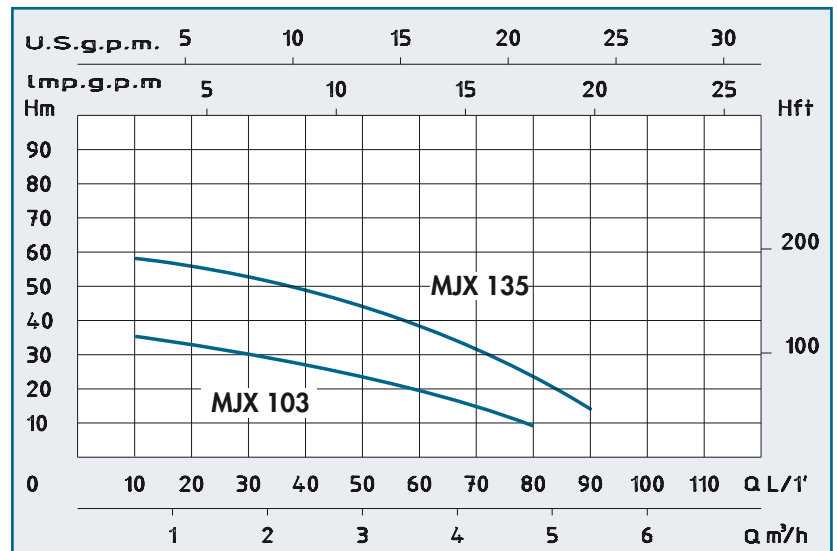

TIPO - TYPE	POTENZA NOMINALE		AMPERE	Q = PORTATA - CAPACITY												
	NOMINAL POWER P2			Monofase Single-phase	m³/h	0,6	1,2	1,8	2,4	3	3,6	4,2	4,8	5,4	6	Dimensioni Dimensions
230V-50Hz	HP	kW	1 x 230V		lt/1'	10	20	30	40	50	60	70	80	90	100	DNA
MJX 103	0,9	0,7	4	H (m)	34	32	30	28	24	20	15	10			1"	1"
MJX 135	1,3	1	5,8	H (m)	58	56	52	48	44	39	31	23	15		1"	1"

GRUPPO DI PRESSURIZZAZIONE A FUNZIONAMENTO AUTOMATICO AUTOMATIC WORKING PRESSURE SYSTEM



75/22

LIMITI D'IMPIEGO

- Temperatura liquido fino a 35°C
- Temperatura ambiente fino a 40°C
- Altezza d'aspirazione manometrica fino a 8 mt.
- Pressostato pre-tarato 1,4÷2,8 bar
- Pressostato pre-tarato 1,6÷3,2 bar (100/25)
- Servizio continuo

MOTORE

- Motore elettrico ad induzione a 2 poli ($n = 2850 \text{ min}^{-1}$)
- Isolamento Classe F
- Protezione IP 44

COMPONENTI

- Serbatoio a membrana
- Tubo flessibile raccordato
- Pressostato con cavi pre-tarato
- Manometro
- Raccordo ottone

OPERATING CONDITIONS

- Liquid temperature up to 35°C
- Ambient temperature up to 40°C
- Total suction lift up to 8 mt.
- Adjusted switch on/off pressure 1,4÷2,8 bar
- Adjusted switch on/off pressure 1,6÷3,2 bar (100/25)
- Continuous duty

MOTOR

- Two-Pole induction motor ($n = 2850 \text{ min}^{-1}$)
- Insulation Class F
- Protection IP 44

COMPONENTS

- Membrane tank
- Flexible hose with connection
- Pre-set pressure switch with cable
- Pressure gauge
- Brass connection



100/25

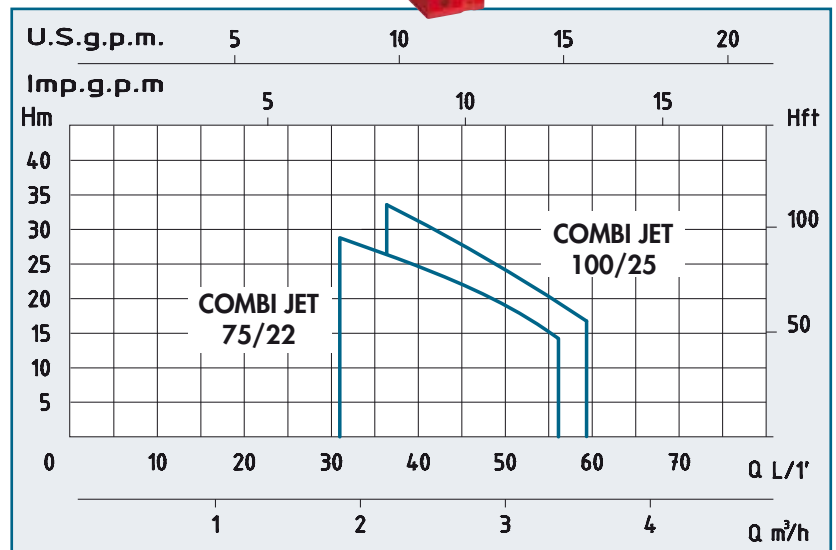

TIPO - TYPE	POTENZA NOMINALE NOMINAL POWER P2		AMPERE	Pressostato pre-tarato Adjusted switch on/off pressure	Q = PORTATA - CAPACITY													
	HP	kW			Monofase Single-phase	1 x 230V	Bar	m³/h	0,6	0,9	1,2	1,5	1,8	2,1	2,4	2,7	3	3,6
Monofase Single-phase																		
230V-50Hz																		
COMBI JET 75/22	0,8	0,6	3,8	1,4 ÷ 2,8	H (m)	38	36	34	32	29	27	25	22	19			1"	1"
COMBI JET 100/25	1	0,75	5	1,6 ÷ 3,2		45	43	40	38	35	33	30	29	26	22		1"	1"

GRUPPO DI PRESSURIZZAZIONE A FUNZIONAMENTO AUTOMATICO AUTOMATIC WORKING PRESSURE SYSTEM



200/60

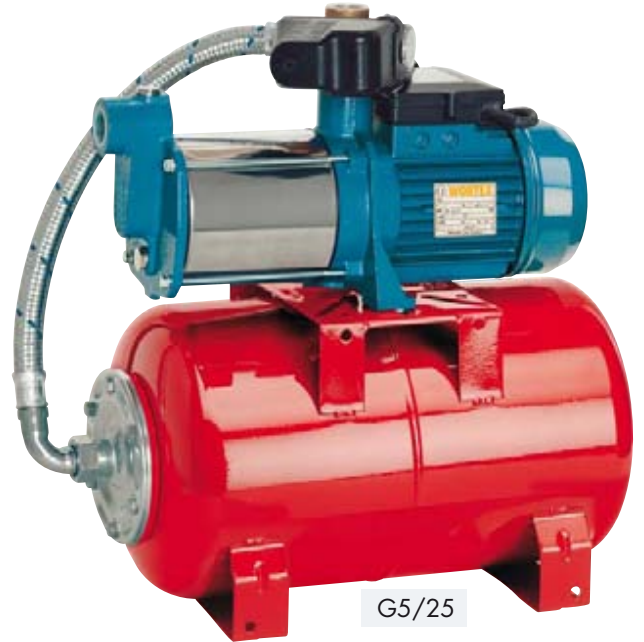

G5/25

LIMITI D'IMPIEGO

- Temperatura liquido fino a 35°C
- Temperatura ambiente fino a 40°C
- Altezza d'aspirazione manometrica fino a 8 mt.
- Pressostato pre-tarato 1,6÷3,2 bar
- Servizio continuo

OPERATING CONDITIONS

- Liquid temperature up to 35°C
- Ambient temperature up to 40°C
- Total suction lift up to 8 mt.
- Adjusted switch on/off pressure 1,6÷3,2 bar
- Continuous duty

MOTORE

- Motore elettrico ad induzione a 2 poli (n = 2850 min⁻¹)
- Isolamento Classe F
- Protezione IP 44

MOTOR

- Two-Pole induction motor (n = 2850 min⁻¹)
- Insulation Class F
- Protection IP 44

COMPONENTI

- Serbatoio a membrana
- Tubo flessibile raccordato
- Pressostato con cavi pre-tarato
- Manometro
- Raccordo ottone

COMPONENTS

- Membrane tank
- Flexible hose with connection
- Pre-set pressure switch with cable
- Pressure gauge
- Brass connection

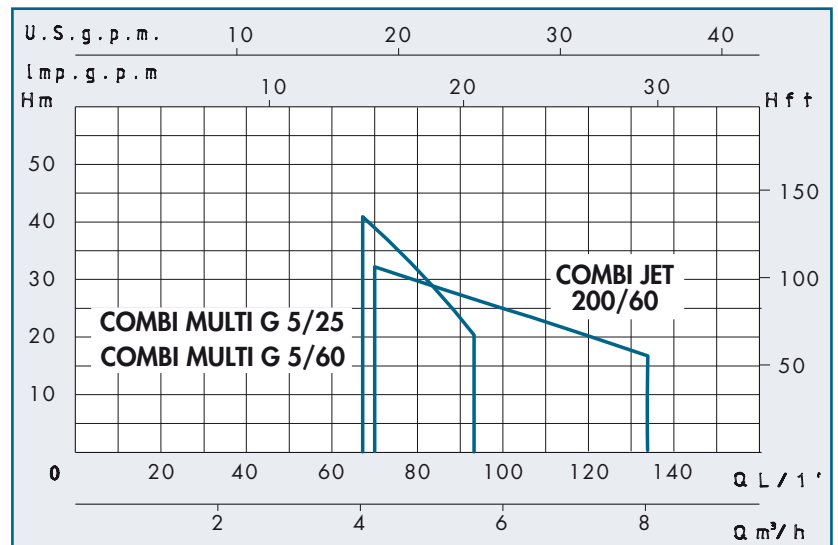

TIPO - TYPE	POTENZA NOMINALE NOMINAL POWER P2		AMPERE	Pressostato pre-tarato Adjusted switch on/off pressure	Q = PORTATA - CAPACITY													
	HP	kW			Monofase Single-phase	Bar	m³/h	0,6	1,2	1,8	2,7	3,6	4,8	5,4	6	7,5	9	Dimensioni Dimensions
Monofase Single-phase																		
230V-50Hz			1 x 230V	Bar	Prevalenza manometrica totale in m.C.A. - Total head in meters w.c.											DNA	DNM	
COMBI JET 200/60	2	1,5	9,3	1,6 ÷ 3,2	H (m)	47	45	43	39	35	30	27	25	18	13	1"	1"	

TIPO - TYPE	POTENZA NOMINALE NOMINAL POWER P2		AMPERE	Pressostato pre-tarato Adjusted switch on/off pressure	Q = PORTATA - CAPACITY													
	HP	kW			Monofase Single-phase	Bar	m³/h	0,6	0,9	1,2	1,5	1,8	2,1	2,4	2,7	3	3,6	Dimensioni Dimensions
Monofase Single-phase																		
230V-50Hz			1 x 230V	Bar	Prevalenza manometrica totale in m.C.A. - Total head in meters w.c.											DNA	DNM	
COMBI MULTI G 5/25	1,5	1,1	6,2	1,6 ÷ 3,2	H (m)	62	61	60	58	55	54	52	50	45	40	1"	1"	
COMBI MULTI G 5/60	1,5	1,1	6,2	1,6 ÷ 3,2		62	61	60	58	55	54	52	50	45	40	1"	1"	

GRUPPO DI PRESSURIZZAZIONE A FUNZIONAMENTO AUTOMATICO AUTOMATIC WORKING PRESSURE SYSTEM



80/22

LIMITI D'IMPIEGO

- Temperatura liquido fino a 35°C
- Temperatura ambiente fino a 40°C
- Altezza d'aspirazione manometrica fino a 8 mt.
- Pressostato pre-tarato 1,4÷2,8 bar
- Pressostato pre-tarato 1,6÷3,2 bar (100/25)
- Servizio continuo

MOTORE

- Motore elettrico ad induzione a 2 poli ($n = 2850 \text{ min}^{-1}$)
- Isolamento Classe F
- Protezione IP 44

COMPONENTI

- Serbatoio a membrana
- Tubo flessibile raccordato
- Pressostato con cavi pre-tarato
- Manometro
- Raccordo ottone

OPERATING CONDITIONS

- Liquid temperature up to 35°C
- Ambient temperature up to 40°C
- Total suction lift up to 8 mt.
- Adjusted switch on/off pressure 1,4÷2,8 bar
- Adjusted switch on/off pressure 1,6÷3,2 bar (100/25)
- Continuous duty

MOTOR

- Two-Pole induction motor ($n = 2850 \text{ min}^{-1}$)
- Insulation Class F
- Protection IP 44

COMPONENTS

- Membrane tank
- Flexible hose with connection
- Pre-set pressure switch with cable
- Pressure gauge
- Brass connection



100/25

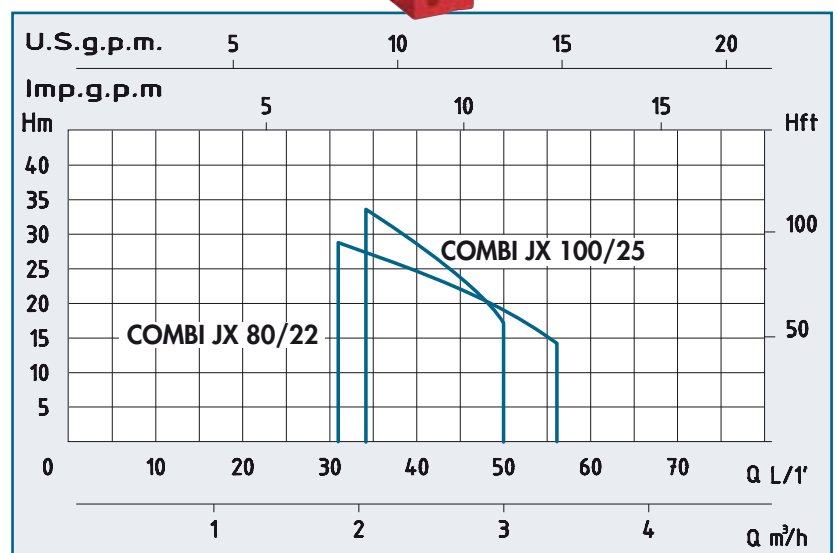

TIPO - TYPE	POTENZA NOMINALE NOMINAL POWER P2		AMPERE	Pressostato pre-tarato Adjusted switch on/off pressure	Q = PORTATA - CAPACITY												
	HP	kW			Monofase Single-phase	Bar	m³/h	0,6	0,9	1,2	1,5	1,8	2,1	2,4	2,7	3	3,6
Monofase Single-phase																	
230V-50Hz			1 x 230V	Bar	Prevalenza manometrica totale in m.C.A. - Total head in meters w.c.												
COMBI JX 80/22	0,8	0,6	3,1	1,4 ÷ 2,8	H (m)	38	32	30	27	25	22	19	17	15		1"	1"
COMBI JX 100/25	1	0,75	5	1,6 ÷ 3,2		46	43	40	38	35	32	30	29	26		1"	1"

GRUPPO DI PRESSURIZZAZIONE
A FUNZIONAMENTO AUTOMATICO
AUTOMATIC WORKING
PRESSURE SYSTEM



130/25



130/25-X

LIMITI D'IMPIEGO

- Temperatura liquido fino a 35°C
- Temperatura ambiente fino a 40°C
- Altezza d'aspirazione manometrica fino a 8 mt.
- Pressostato pre-tarato 1,6÷3,2 bar
- Servizio continuo

MOTORE

- Motore elettrico ad induzione a 2 poli ($n = 2850 \text{ min}^{-1}$)
- Isolamento Classe F
- Protezione IP 44

COMPONENTI

- Serbatoio a membrana
- Tubo flessibile raccordato
- Pressostato con cavi pre-tarato
- Manometro
- Raccordo ottone

OPERATING CONDITIONS

- Liquid temperature up to 35°C
- Ambient temperature up to 40°C
- Total suction lift up to 8 mt.
- Adjusted switch on/off pressure 1,6÷3,2 bar
- Continuous duty

MOTOR

- Two-Pole induction motor ($n = 2850 \text{ min}^{-1}$)
- Insulation Class F
- Protection IP 44

COMPONENTS

- Membrane tank
- Flexible hose with connection
- Pre-set pressure switch with cable
- Pressure gauge
- Brass connection

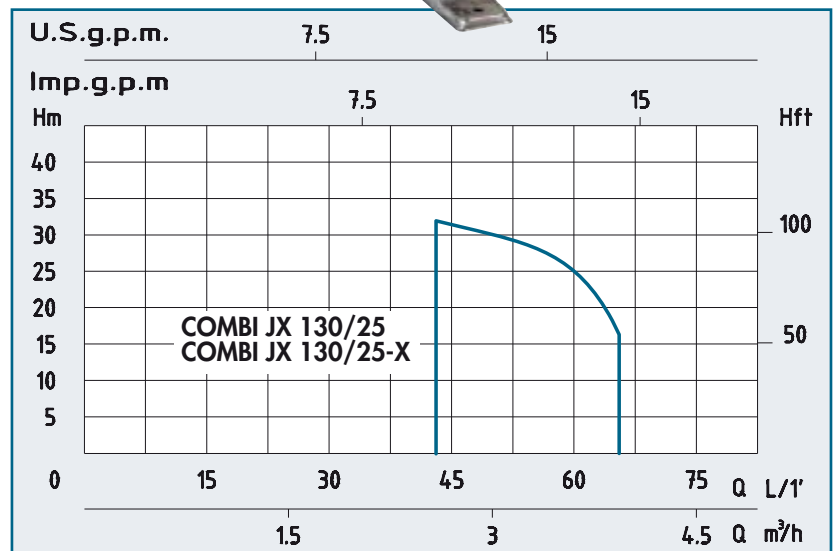

TIPO - TYPE	POTENZA NOMINALE NOMINAL POWER P2		AMPERE	Pressostato pre-tarato Adjusted switch on/off pressure	Q = PORTATA - CAPACITY													
	HP	kW			Monofase Single-phase	1 x 230V	Bar	m³/h	0,6	0,9	1,2	1,5	1,8	2,1	2,4	2,7	3	3,6
Monofase Single-phase																		
230V-50Hz																		
COMBI JX 130/25	1,3	1	5,8	1,6 ÷ 3,2														
COMBI JX 130/25-X	1,3	1	5,8	1,6 ÷ 3,2														

ELETTROPOMPE CENTRIFUGHE MULTIGIRANTI CENTRIFUGAL MULTI-IMPELLER PUMPS

LIMITI D'IMPIEGO

- Pressione max. d'esercizio: 10 bar
- Temperatura liquido fino a 35°C
- Temperatura ambiente fino a 40°C
- Altezza d'aspirazione manometrica fino a 7 mt.
- Servizio continuo

MOTORE

- Motore elettrico ad induzione a 2 poli (n = 2850 min-1)
- Isolamento Classe F
- Protezione IP 44

MATERIALI

- Corpo pompa Ghisa
- Supporto motore Ghisa
- Girante Noryl
- Diffusori Noryl
- Camicia pompa Acciaio Inox
- Albero motore Acciaio Inox
- Tenute meccaniche Ceramica/Grafite



OPERATING CONDITIONS

- Max working pressure: 10 bar
- Liquid temperature up to 35°C
- Ambient temperature up to 40°C
- Total suction lift up to 7 mt.
- Continuous duty

MOTOR

- Two-Pole induction motor (n = 2850 min-1)
- Insulation Class F
- Protection IP 44

MATERIALS

- Pump body Cast Iron
- Motor support Cast Iron
- Impeller Noryl
- Diffusers Noryl
- Pump casing Stainless Steel
- Shaft with rotor Stainless Steel
- Mechanical seal Ceramic/Graphite

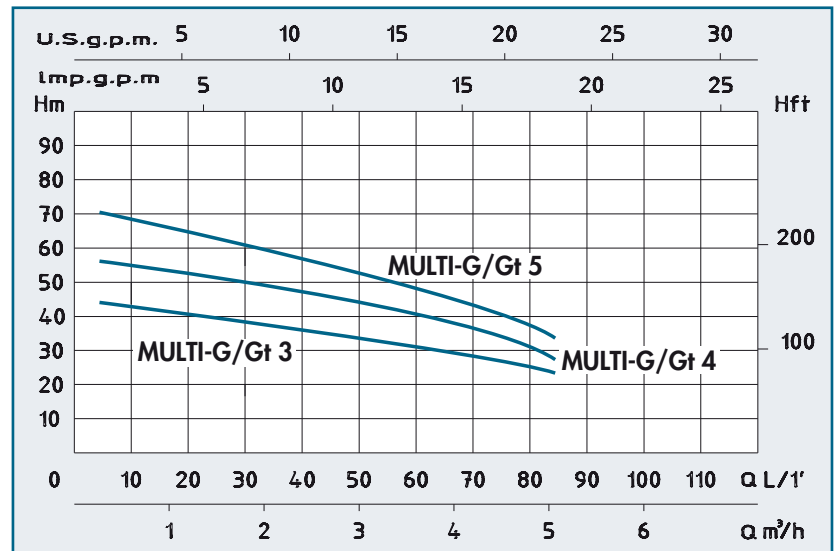

TIPO - TYPE		POTENZA NOMINALE NOMINAL POWER P2		AMPERE		Q = PORTATA - CAPACITY													
Monofase Single-phase	Trifase Three-phase	HP	kW	Monofase Single-phase	Trifase Three-phase	m³/h	0,6	1,2	1,8	2,7	3,6	4,5	5,4	7,2	8,4	9,6	Dimensioni Dimensions		
230V-50Hz	230/400V-50Hz			1 x 230V	3 x 400V	lt/1'	10	20	30	45	60	75	90	120	140	160	DNA	DNM	
MULTI-G3	MULTI-Gt3	0,8	0,6	3,5	1,8	H (m)	34	33	31	28	23	18	13					1"	1"
MULTI-G4	MULTI-Gt4	1	0,7	4,8	2,2		45	44	43	38	33	25	18					1"	1"
MULTI-G5	MULTI-Gt5	1,5	1,1	6,2	3		60	56	53	47	40	33	24					1"	1"

ELETTROPOMPE CENTRIFUGHE MULTIGIRANTI CENTRIFUGAL MULTI-IMPELLER PUMPS

LIMITI D'IMPIEGO

- Pressione max. d'esercizio: 10 bar
- Temperatura liquido fino a 35°C
- Temperatura ambiente fino a 40°C
- Altezza d'aspirazione manometrica fino a 7 mt.
- Servizio continuo

MOTORE

- Motore elettrico ad induzione a 2 poli (n = 2850 min-1)
- Isolamento Classe F
- Protezione IP 44

MATERIALI

- Corpo pompa Ghisa
- Supporto motore Ghisa
- Girante Noryl
- Diffusori Noryl
- Camicia pompa Acciaio Inox
- Albero motore Acciaio Inox
- Tenute meccaniche Silicio/Silicio



OPERATING CONDITIONS

- Max working pressure: 10 bar
- Liquid temperature up to 35°C
- Ambient temperature up to 40°C
- Total suction lift up to 7 mt.
- Continuous duty

MOTOR

- Two-Pole induction motor (n = 2850 min-1)
- Insulation Class F
- Protection IP 44

MATERIALS

- Pump body Cast Iron
- Motor support Cast Iron
- Impeller Noryl
- Diffusers Noryl
- Pump casing Stainless Steel
- Shaft with rotor Stainless Steel
- Mechanical seal Silicon/Silicon

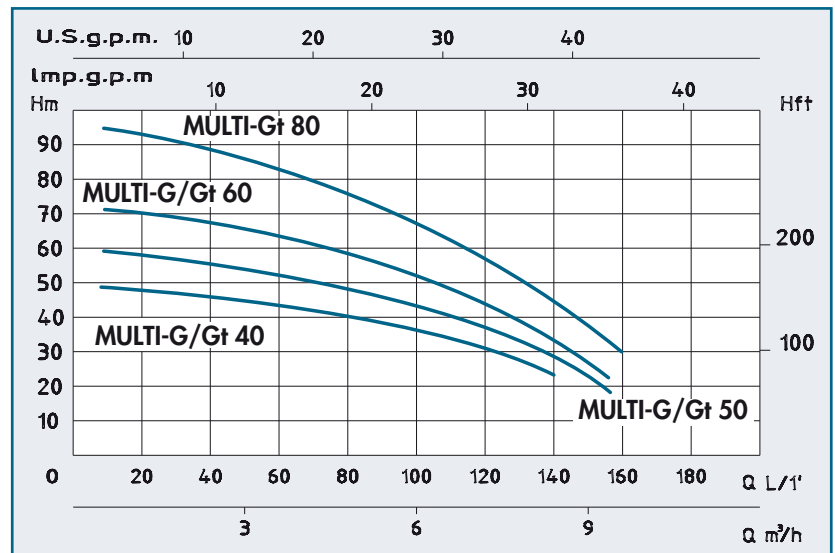

TIPO - TYPE		POTENZA NOMINALE NOMINAL POWER P2		AMPERE		Q = PORTATA - CAPACITY												
Monofase Single-phase	Trifase Three-phase	HP	kW	Monofase Single-phase	Trifase Three-phase	m³/h	0,6	1,2	1,8	2,7	3,6	4,5	5,4	7,2	8,4	9,6	Dimensioni Dimensions	
230V-50Hz	230/400V-50Hz			1 x 230V	3 x 400V	lt/1'	10	20	30	45	60	75	90	120	140	160	DNA	DNM
MULTI-G40	MULTI-Gt40	2	1,5	9,3	4,2	H (m)	49	48	47	44	43	40	37	30	23	15	1 1/4	1"
MULTI-G50	MULTI-Gt50	2,5	1,9	10	4,6		59	57	56	55	52	48	44	34	25	18	1 1/4	1"
MULTI-G60	MULTI-Gt60	3	2,2	12	5,3		71	68	67	65	64	58	53	41	32	22	1 1/4	1"
	MULTI-Gt80	4	3		6,6		95	92	90	88	83	78	73	58	46	30	1 1/4	1"

ELETTROPOMPE AUTOADESCANTI CENTRIFUGHE MULTIGIRANTI SELF PRIMING CENTRIFUGAL MULTI-IMPELLER PUMPS

LIMITI D'IMPIEGO

- Pressione max. d'esercizio: 10 bar
- Temperatura liquido fino a 35°C
- Temperatura ambiente fino a 40°C
- Altezza d'aspirazione manometrica fino a 7 mt.
- Servizio continuo

MOTORE

- Motore elettrico ad induzione a 2 poli (n = 2850 min-1)
- Isolamento Classe F
- Protezione IP 44

MATERIALI

- Corpo pompa Ghisa
- Supporto motore Ghisa
- Girante Noryl
- Diffusori Noryl
- Camicia pompa Acciaio Inox
- Albero motore Acciaio Inox
- Tenute meccaniche Ceramica/Grafite



OPERATING CONDITIONS

- Max working pressure: 10 bar
- Liquid temperature up to 35°C
- Ambient temperature up to 40°C
- Total suction lift up to 7 mt.
- Continuous duty

MOTOR

- Two-Pole induction motor (n = 2850 min-1)
- Insulation Class F
- Protection IP 44

MATERIALS

- Pump body Cast Iron
- Motor support Cast Iron
- Impeller Noryl
- Diffusers Noryl
- Pump casing Stainless Steel
- Shaft with rotor Stainless Steel
- Mechanical seal Ceramic/Graphite

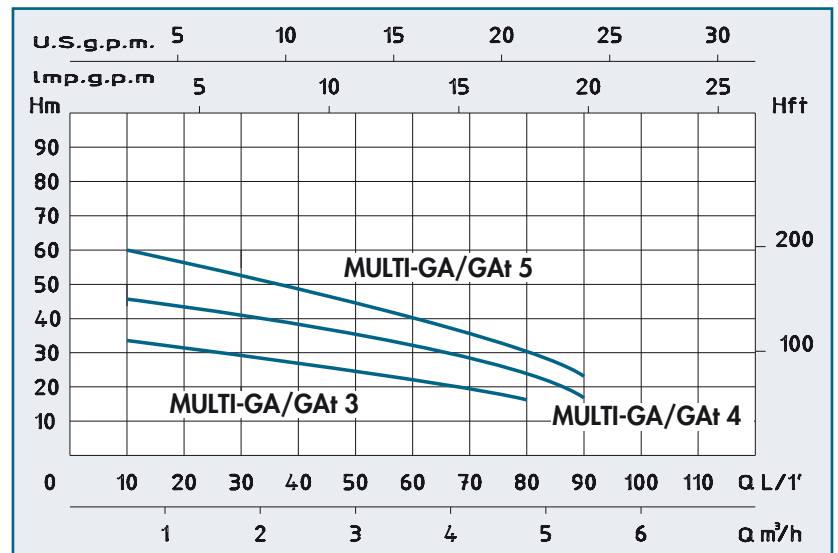

TIPO - TYPE		POTENZA NOMINALE NOMINAL POWER P2		AMPERE		Q = PORTATA - CAPACITY													
Monofase Single-phase	Trifase Three-phase	HP	kW	Monofase Single-phase	Trifase Three-phase	m³/h	0,6	1,2	1,8	2,7	3,6	4,5	5,4	7,2	8,4	9,6	Dimensioni Dimensions		
230V-50Hz	230/400V-50Hz			1 x 230V	3 x 400V	lt/1'	10	20	30	45	60	75	90	120	140	160	DNA	DNM	
MULTI-GA3	MULTI-GA43	0,8	0,6	3,6	2	H (m)	34	33	31	28	23	18	13					1"	1"
MULTI-GA4	MULTI-GA44	1	0,7	5	2,2		45	44	43	38	33	25	18					1"	1"
MULTI-GA5	MULTI-GA45	1,5	1,1	6,2	3		60	56	53	47	40	33	24					1"	1"

ELETTROPOMPE MULTISTADIO AD ASSE VERTICALE MULTISTAGE VERTICAL ELECTRIC PUMPS

LIMITI D'IMPIEGO

- Pressione max. d'esercizio: 10 bar
- Temperatura liquido fino a 35°C
- Temperatura ambiente fino a 40°C
- Altezza d'aspirazione manometrica fino a 7 mt.
- Servizio continuo

OPERATING CONDITIONS

- Max working pressure: 10 bar
- Liquid temperature up to 35°C
- Ambient temperature up to 40°C
- Total suction lift up to 7 mt.
- Continuous duty

MOTORE

- Motore elettrico ad induzione a 2 poli (n = 2850 min-1)
- Isolamento Classe F
- Protezione IP 55

MOTOR

- Two-Pole induction motor (n = 2850 min-1)
- Insulation Class F
- Protection IP 55

MATERIALI

- Corpo pompa Ghisa
- Supporto motore Ghisa
- Girante Noryl
- Diffusore Noryl
- Camicia pompa Acciaio Inox
- Albero motore Acciaio Inox
- Tenute meccaniche Silicio/Silicio

MATERIALS

- Pump body Cast Iron
- Motor Support Cast Iron
- Impeller Noryl
- Diffuser Noryl
- Pump casing Stainless Steel
- Shaft with rotor Stainless Steel
- Mechanical seal Silicon/Silicon

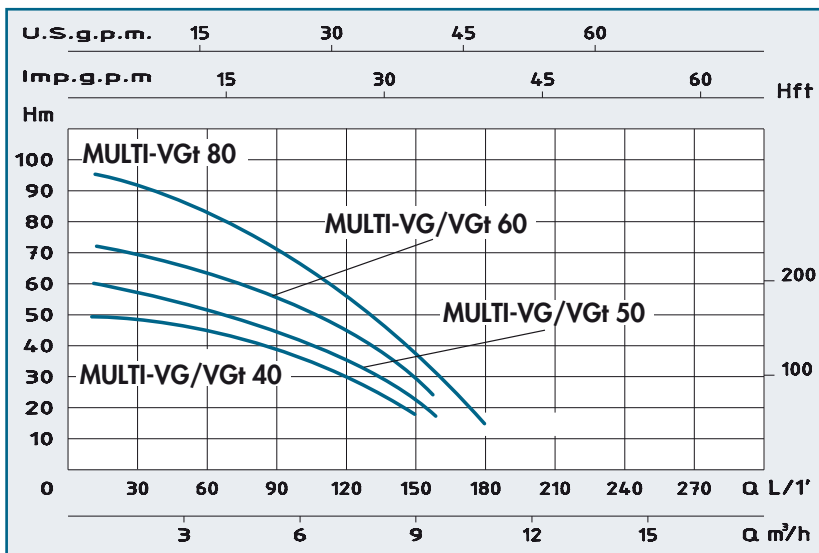

TIPO - TYPE		POTENZA NOMINALE NOMINAL POWER P2		AMPERE		Q = PORTATA - CAPACITY													
Monofase Single-phase	Trifase Three-phase	HP	kW	Monofase Single-phase	Trifase Three-phase	m³/h	0	1,2	2,4	3,6	4,8	6	7,2	8,4	9,6	10,8	Dimensioni Dimensions		
						lt/1'	0	20	40	60	80	100	120	140	160	180			
230V-50Hz	230/400V-50Hz			1 x 230V	3 x 400V	Prevalenza manometrica totale in m.C.A. - Total head in meters w.c.											DNA	DNM	
MULTI-VG 40	MULTI-VG† 40	2	1,5	9,3	4,2	H (m)	50	48	45	43	39	35	30	23	15			1"1/4	1"
MULTI-VG 50	MULTI-VG† 50	2,5	1,85	10	4,6		60	57	54	52	47	41	34	25	18			1"1/4	1"
MULTI-VG 60	MULTI-VG† 60	3	2,2	12	5,3		73	68	66	64	57	49	41	32	22			1"1/4	1"
	MULTI-VG† 80	4	3		6,6		97	92	87	83	77	69	58	46	30	15		1"1/4	1"

ELETTROPOMPE AUTOADESCANTI MONOBLOCCO SELFPRIMING MONOBLOCK PUMPS



LIMITI D'IMPIEGO

- Temperatura liquido fino a 60° C
- Temperatura ambiente fino a 40° C
- Altezza d'aspirazione manometrica fino a 7 mt.
- Servizio continuo

MOTORE

- Motore elettrico ad induzione a 2 poli (n = 2850 min-1)
- Isolamento Classe F
- Protezione IP 44

MATERIALI

- Corpo pompa Ghisa
- Supporto motore Ghisa
- Girante Ghisa
- Albero motore Acciaio Inox
- Tenute meccaniche Ceramica/Carbone

OPERATING CONDITIONS

- Max working pressure: 10 bar
- Liquid temperature up to 90°C
- Ambient temperature up to 40°C
- Total suction lift up to 7 mt.
- Continuous duty

MOTOR

- Two-Pole induction motor (n = 2850 min-1)
- Insulation Class F
- Protection IP 44

MATERIALS

- Pump body Cast Iron
- Motor Support Cast Iron
- Impeller Cast Iron
- Shaft with motor Stainless Steel
- Mechanical seal Carbon/Ceramic

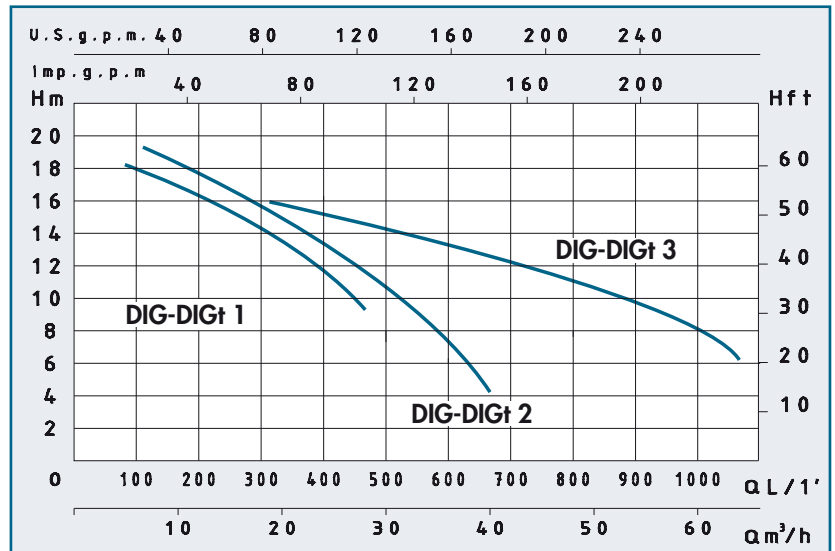

TIPO - TYPE		POTENZA NOMINALE NOMINAL POWER P2		AMPERE		Q = PORTATA - CAPACITY													
Monofase Single-phase	Trifase Three-phase	HP	kW	Monofase Single-phase	Trifase Three-phase	m³/h	1,5	3	6	12	18	24	36	48	60	72	Dimensioni Dimensions		
				1 x 230V	3 x 400V	lit/1'	25	50	100	200	300	400	600	800	1000	1200			
230V-50Hz	230/400V-50Hz					Prevalenza manometrica totale in m.C.A. - Total head in meters w.c.											DNA	DNM	
DIG 1	DIGt 1	1,5	1,1	7	3	H (m)	18	17	16	15	12	9					2"	2"	
DIG 2	DIGt 2	2	1,5	9,3	4,2			19	18	16	14	11	4					2"	2"
DIG 3	DIGt 3	3	2,2	12	5,3				17	16	15	14	13	10	6			3"	3"

ELETTROPOMPE AUTOADESCANTI IN BRONZO SELFPRIMING BRONZE PUMPS



LIMITI D'IMPIEGO

- Temperatura liquido fino a 35°C
- Temperatura ambiente fino a 40°C
- Altezza d'aspirazione manometrica fino a 6 mt.
- Servizio continuo

MOTORE

- Motore elettrico ad induzione a 2 poli (n = 2850 min-1)
- Isolamento Classe F
- Protezione IP 44

MATERIALI

- Corpo pompa Bronzo
- Supporto motore Ghisa
- Girante Bronzo
- Albero motore Acciaio Inox
- Doppio anello di tenuta

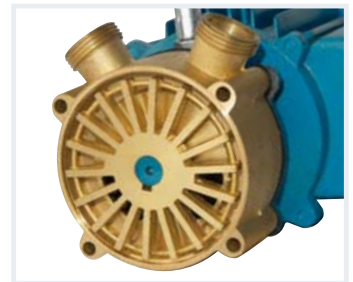

OPERATING CONDITIONS

- Liquid temperature up to 35°C
- Ambient temperature up to 40°C
- Total suction lift up to 6 mt.
- Continuous duty

MOTOR

- Two-Pole induction motor (n = 2850 min-1)
- Insulation Class F
- Protection IP 44

MATERIALS

- Pump body Bronze
- Motor support Cast Iron
- Impeller Bronze
- Shaft with rotor Stainless steel
- Double oil seal

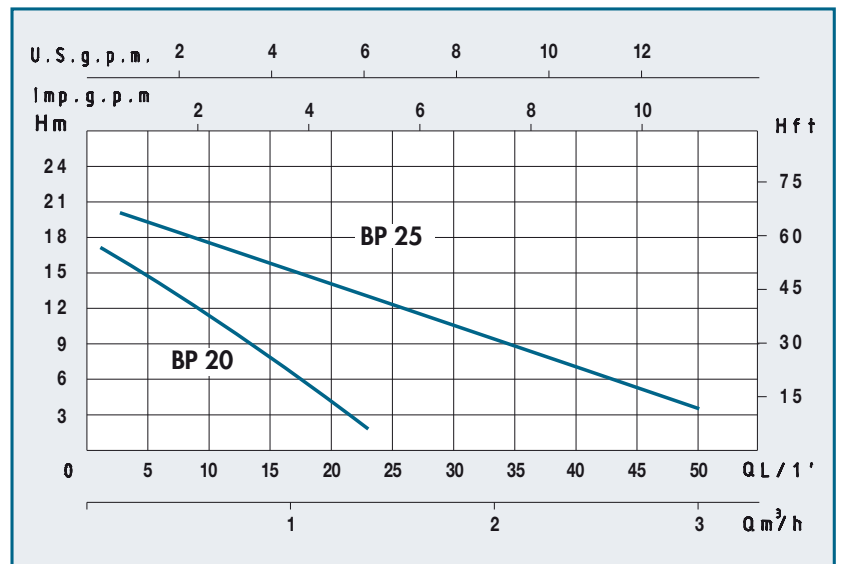

TIPO - TYPE	POTENZA NOMINALE NOMINAL POWER P2		AMPERE	Q = PORTATA - CAPACITY													
	HP	kW		Monofase Single-phase	m³/h	0,3	0,6	0,9	1,2	1,5	1,8	2,1	2,4	3	3,3	Dimensioni Dimensions	
230V-50Hz			1 x 230V	Prevalenza manometrica totale in m.C.A. - Total head in meters w.c.												DNA	DNM
BP 20	0,5	0,37	2	H (m)	14	10	8	4	1							Ø 20	Ø 20
BP 25	1	0,75	4,8		19	17	15	13	11	10	8	6	4	1	Ø 25	Ø 25	

ELETTROPOMPE SOMMERSE PER DRENAGGIO SUBMERSIBLE DRAINAGE PUMPS

LIMITI D'IMPIEGO

- Temperatura liquido fino a 35° C
- Profondità d'immersione 5 mt.
- Passaggio solidi - JD 200 Ø 5 mm
- Passaggio solidi - JD 300 Ø 5 mm
- Passaggio solidi - JD 750 Ø 5 mm
- Livello min. d'asp. - JD 200 Ø 20 mm
- Livello min. d'asp. - JD 300 Ø 30 mm
- Livello min. d'asp. - JD 750 Ø 30 mm

MOTORE

- Protezione amperometrica a riarmo automatico incorporata
- Condensatore permanente inserito
- Isolamento Classe F
- Protezione IP 68

MATERIALI

- Maniglia Polipropilene
- Corpo pompa Polipropilene
- Girante Noryl
- Cassa motore Acciaio Inox
- Albero motore Acciaio Inox
- Tenuta meccanica

OPERATING CONDITIONS

- Liquid temperature up to 35°C
- Submersion depth 5 mt.
- Grain size inlet - JD 200 Ø 5 mm
- Grain size inlet - JD 300 Ø 5 mm
- Grain size inlet - JD 300 Ø 5 mm
- Min. suction level - JD 300 Ø 20 mm
- Min. suction level - JD 300 Ø 30 mm
- Min. suction level - JD 300 Ø 30 mm

MOTOR

- Built-in overload motor protector with automatic reset
- Permanent split capacitor
- Insulation Class F
- Protection IP 68

MATERIALS

- Handle Moplen
- Pump body Moplen
- Impeller Noryl
- Motor casing Stainless Steel
- Shaft with rotor Stainless Steel
- Mechanical seal

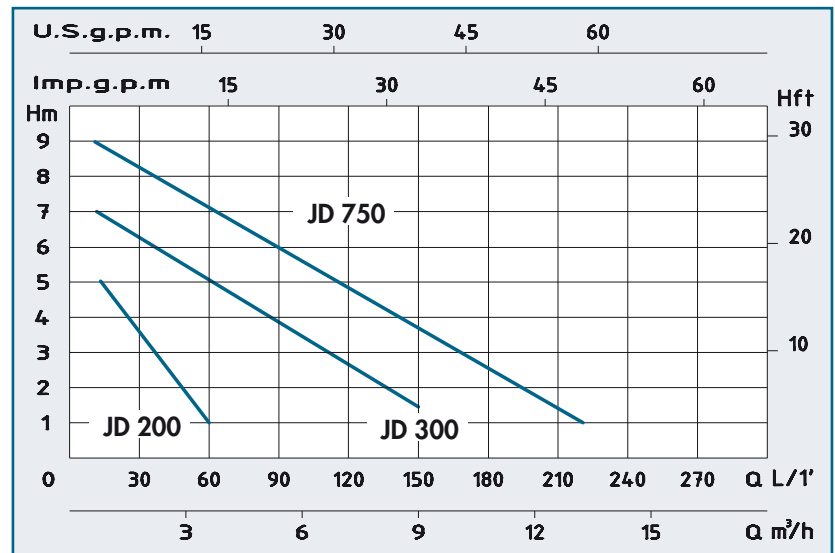

TIPO - TYPE	POTENZA ASSORBITA INPUT POWER P1	AMPERE	Q = PORTATA - CAPACITY												
			Prevalenza manometrica totale in m.C.A. - Total head in meters w.c.												
Con galleggiante With float switch		Monofase Single-phase	m³/h	0	1,5	3	4,5	6	7,8	9	10,8	12	13,8	Dimensioni Dimensions	
			lt/1'	0	25	50	75	100	130	150	180	200	230		
230V-50Hz	Watt	1 x 230V	Prevalenza manometrica totale in m.C.A. - Total head in meters w.c.											DNM	
JD 200	200 W	0,9	H (m)	5	3,5	2,5	1							1"	
JD 300	300 W	1,3		7	6	5	4	3	2	1,5					1"½
JD 750	750 W	3,5		9	8,5	8	7	5,8	5,5	5	3	2	1		1"½

ELETTROPOMPE SOMMERSE PER ACQUE CARICHE SUBMERSIBLE PUMPS FOR DIRTY WATER

LIMITI D'IMPIEGO

- Temperatura liquido fino a 35° C
- Profondità d'immersione 5 mt.
- Passaggio solidi - JV 400 Ø 35 mm
- Passaggio solidi - JV 750 Ø 35 mm
- Passaggio solidi - JV 1000 Ø 35 mm
- Livello min. d'asp. - JV 400 Ø 50 mm
- Livello min. d'asp. - JV 750 Ø 50 mm
- Livello min. d'asp. - JV 1000 Ø 50 mm

MOTORE

- Protezione amperometrica a riarmo automatico incorporata
- Condensatore permanente inserito
- Isolamento Classe F
- Protezione IP 68

MATERIALI

- Maniglia Polipropilene
- Corpo pompa Polipropilene
- Girante Noryl
- Cassa motore Acciaio Inox
- Albero motore Acciaio Inox
- Tenuta meccanica

OPERATING CONDITIONS

- Liquid temperature up to 35°C
- Submersion depth 5 mt.
- Grain size inlet - JV 400 Ø 35 mm
- Grain size inlet - JV 750 Ø 35 mm
- Grain size inlet - JV 1000 Ø 35 mm
- Min. suction level - JV 400 Ø 50 mm
- Min. suction level - JV 750 Ø 50 mm
- Min. suction level - JV 1000 Ø 50 mm

MOTOR

- Built-in overload motor protector with automatic reset
- Permanent split capacitor
- Insulation Class F
- Protection IP 68

MATERIALS

- Handle Moplen
- Pump body Moplen
- Impeller Noryl
- Motor casing Stainless Steel
- Shaft with rotor Stainless Steel
- Mechanical seal

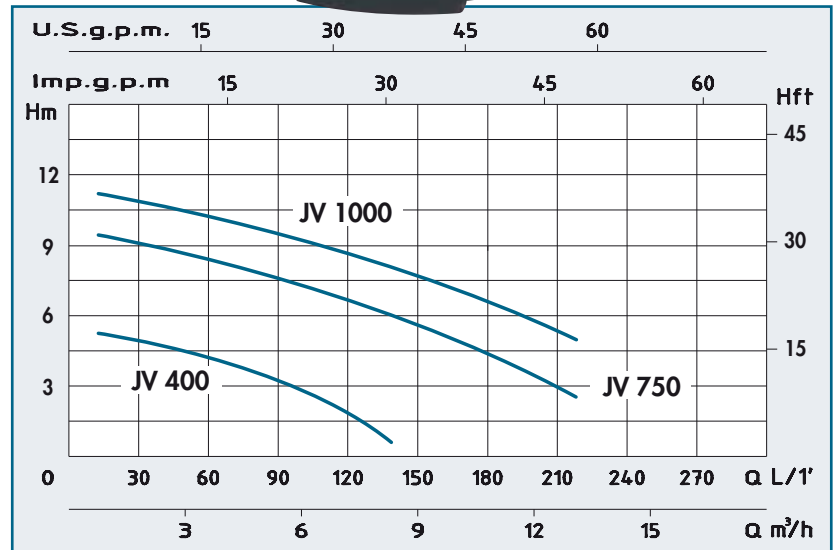

TIPO - TYPE	POTENZA ASSORBITA INPUT POWER P1	AMPERE	Q = PORTATA - CAPACITY											
			Prevalenza manometrica totale in m.C.A. - Total head in meters w.c. DNM											
Con galleggiante With float switch		Monofase Single-phase	m³/h	0	1,5	3	4,5	6	7,8	9	10,8	12	13,8	Dimensioni Dimensions
			lt/1'	0	25	50	75	100	130	150	180	200	230	
230V-50Hz	Watt	1 x 230V												
JV 400	400 W	2,0	H (m)	5	4,5	4	3,5	2,5	1					1"1/2
JV 750	750 W	3,5		9,2	8,8	8,2	8	7	6,5	6	4	3	2	1"1/2
JV 1000	1000 W	4,8		11	11,2	10	9	8	7,5	7	6	5	4	1"1/2

ELETTROPOMPE SOMMERSE INOX PER DRENAGGIO STAINLESS STEEL SUBMERSIBLE DRAINAGE PUMPS

LIMITI D'IMPIEGO

- Temperatura liquido fino a 35° C
- Profondità d'immersione 5 mt.
- Passaggio solidi - JDX 350 Ø 2 mm
- Passaggio solidi - JDX 600 Ø 3 mm
- Livello min. d'asp. - JDX 350 Ø 2 mm
- Livello min. d'asp. - JDX 600 Ø 30 mm

MOTORE

- Protezione amperometrica a riarmo automatico incorporata
- Condensatore permanente inserito
- Isolamento Classe F
- Protezione IP 68

MATERIALI

- Maniglia Polipropilene
- Corpo pompa Acciaio Inox
- Girante Noryl
- Cassa motore Acciaio Inox
- Albero motore Acciaio Inox
- Tenuta meccanica



350

600

OPERATING CONDITIONS

- Liquid temperature up to 35°C
- Submersion depth 5 mt.
- Grain size inlet - JDX 350 Ø 2 mm
- Grain size inlet - JDX 600 Ø 3 mm
- Min. suction level - JDX 350 Ø 2 mm
- Min. suction level - JDX 600 Ø 30 mm

MOTOR

- Built-in overload motor protector with automatic reset
- Permanent split capacitor
- Insulation Class F
- Protection IP 68

MATERIALS

- Handle Moplen
- Pump body Stainless Steel
- Impeller Noryl
- Motor casing Stainless Steel
- Shaft with rotor Stainless Steel
- Mechanical seal

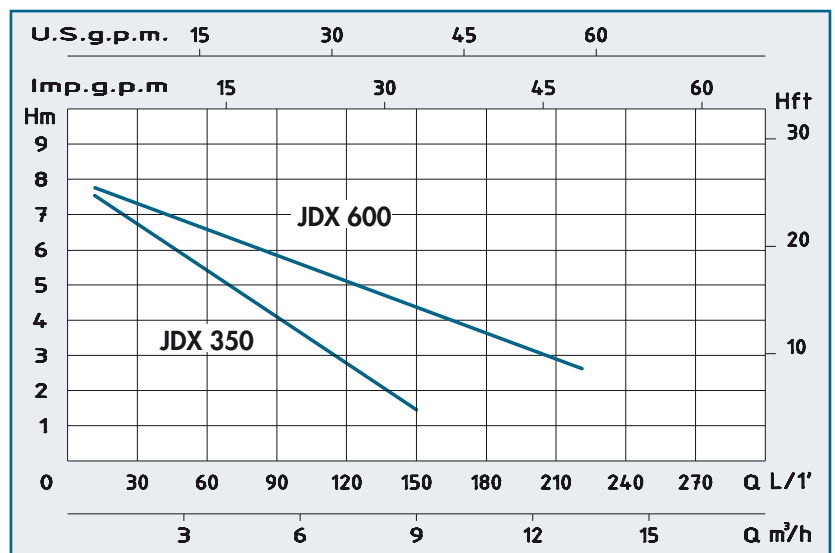

TIPO - TYPE	POTENZA ASSORBITA INPUT POWER P1	AMPERE	Q = PORTATA - CAPACITY											
			m³/h	0	1,5	3	4,5	6	7,8	9	10,5	12	13,5	Dimensioni Dimensions
Con galleggiante With float switch	P1	Monofase Single-phase	lt/1'	0	25	50	75	100	130	150	175	200	225	
230V-50Hz	Watt	1 x 230V	Prevalenza manometrica totale in m.C.A. - Total head in meters w.c. DNM											
JDX 350	350 W	1,4	H (m)	7,5	6,5	5	4,5	3,8	2,5	1,5				1"1/4
JDX 600	600 W	2,8		7,7	7,3	6,8	6,3	5,7	5,2	4,5	4	3,3	2,6	1"1/2

ELETTROPOMPE SOMMERSE INOX PER ACQUE CARICHE STAINLESS STEEL SUBMERSIBLE PUMPS FOR DIRTY WATER

LIMITI D'IMPIEGO

- Temperatura liquido fino a 35° C
- Profondità d'immersione 5 mt.
- Passaggio solidi Ø 20 mm
- Livello min. d'asp. Ø 30 mm

MOTORE

- Protezione amperometrica a riarmo automatico incorporata
- Condensatore permanente inserito
- Isolamento Classe F
- Protezione IP 68

MATERIALI

- Maniglia Polipropilene
- Corpo pompa Acciaio Inox
- Girante Noryl
- Cassa motore Acciaio Inox
- Albero motore Acciaio Inox
- Tenuta meccanica

OPERATING CONDITIONS

- Liquid temperature up to 35°C
- Submersion depth 5 mt.
- Grain size inlet Ø 20 mm
- Min. suction level Ø 30 mm

MOTOR

- Built-in overload motor protector with automatic reset
- Permanent split capacitor
- Insulation Class F
- Protection IP 68

MATERIALS

- Handle Moplen
- Pump body Stainless Steel
- Impeller Noryl
- Motor casing Stainless Steel
- Shaft with rotor Stainless Steel
- Mechanical seal

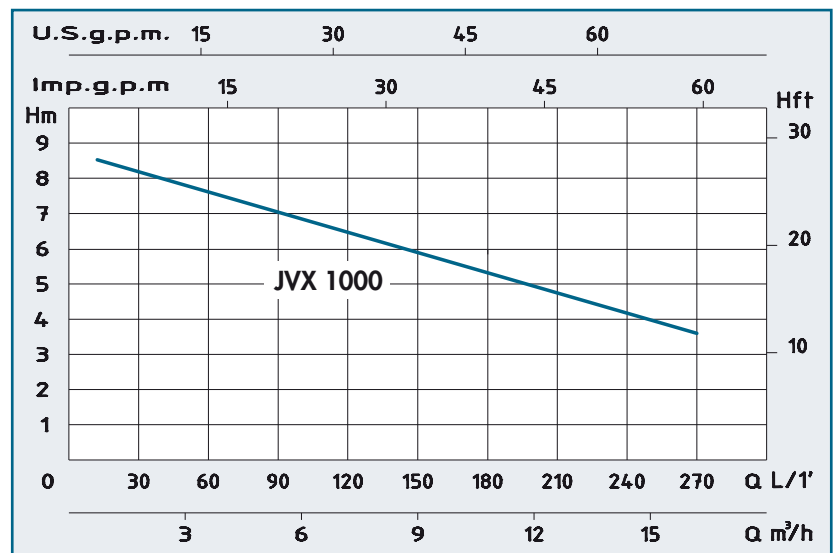

TIPO - TYPE	POTENZA ASSORBITA INPUT POWER P1	AMPERE	Q = PORTATA - CAPACITY											
			m³/h	0	1,8	3,6	5,4	7,2	9	10,8	12,6	14,4	16,2	Dimensioni Dimensions
Con galleggiante With float switch		Monofase Single-phase	lt/1'	0	30	60	90	120	150	180	210	240	270	
230V-50Hz	Watt	1 x 230V	Prevalenza manometrica totale in m.C.A. - Total head in meters w.c. DNM											
JVX 1000	1000 W	4,8	H (m)	8,5	8,2	7,5	7	6,7	6	5,2	4,8	4,2	3,6	1"1/2

ELETTROPOMPE SOMMERSE INOX PER DRENAGGIO STAINLESS STEEL SUBMERSIBLE DRAINAGE PUMPS

LIMITI D'IMPIEGO

- Temperatura liquido fino a 35° C
- Profondità d'immersione 5 mt.
- Passaggio solidi -DXG 400 Ø 8mm
- Passaggio solidi -DXG 600 Ø 10mm
- Livello min. d'asp. -DXG 400 Ø 15mm
- Livello min. d'asp. -DXG 600 Ø 20mm

MOTORE

- Protezione amperometrica a riarmo automatico incorporata
- Condensatore permanente inserito
- Isolamento Classe F
- Protezione IP 68

MATERIALI

- Corpo pompa Acciaio Inox
- Girante Noryl
- Cassa motore Acciaio Inox
- Albero motore Acciaio Inox
- Doppio anello di tenuta

OPERATING CONDITIONS

- Liquid temperature up to 35°C
- Submersion depth 5 mt.
- Grain size inlet -DXG 400 Ø 8mm
- Grain size inlet -DXG 600 Ø 10mm
- Min. suction level -DXG 400 Ø 15mm
- Min. suction level -DXG 600 Ø 20mm

MOTOR

- Built-in overload motor protector with automatic reset
- Permanent split capacitor
- Insulation Class F
- Protection IP 68

MATERIALS

- Pump body Stainless Steel
- Impeller Noryl
- Motor casing Stainless Steel
- Shaft with rotor Stainless Steel
- Double oil seal

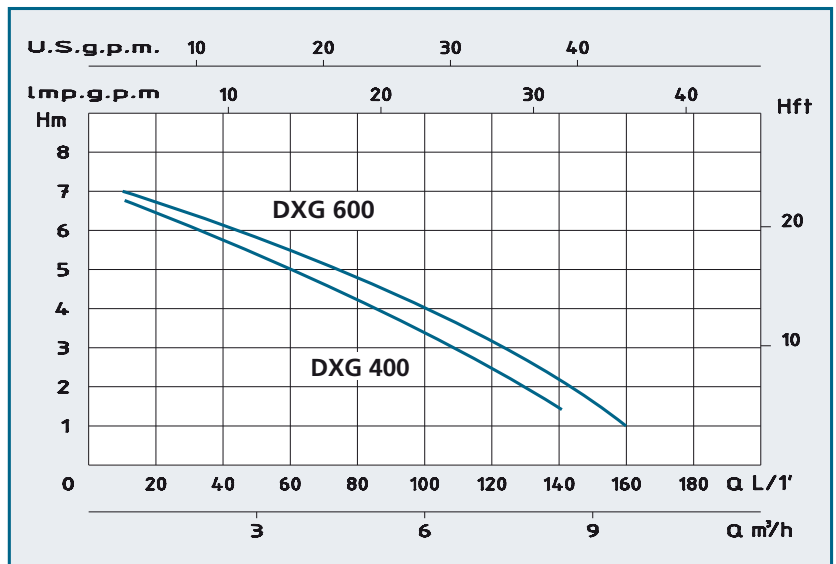

TIPO - TYPE	POTENZA ASSORBITA INPUT POWER P1	AMPERE	Q = PORTATA - CAPACITY											
			m³/h	0,6	1,2	1,8	2,4	3,6	5,4	7,2	8,4	9,6	10,8	Dimensioni Dimensions
Con galleggiante With float switch		Monofase Single-phase	lt/1'	10	20	30	40	60	90	120	140	160	180	
230V-50Hz	Watt	1 x 230V	Prevalenza manometrica totale in m.C.A. - Total head in meters w.c. DNM											
DXG 400	400 W	2	H (m)	6,8	6,5	6,2	5,8	5	3,4	2,2	1,5			1"1/4
DXG 600	550 W	3		7	6,8	6,7	6,5	5,5	4,5	3	2	1		1"1/4

ELETTROPOMPE SOMMERSE INOX PER ACQUE CARICHE STAINLESS STEEL SUBMERSIBLE PUMPS FOR DIRTY WATER

LIMITI D'IMPIEGO

- Temperatura liquido fino a 35° C
- Profondità d'immersione 5 mt.
- Passaggio solidi Ø 35 mm
- Livello min. d'aspiraz. 65 mm
- Servizio continuo

MOTORE

- Doppia camera con motore in bagno d'olio per raffreddamento e lubrificazione cuscinetti
- Tenuta meccanica in bagno d'olio
- Condensatore permanente inserito
- Isolamento Classe F
- Protezione IP 68

MATERIALI

- Maniglia Acciaio Inox
- Cassa motore Acciaio Inox
- Corpo pompa Ghisa (DXG 1100-1200)
- Corpo pompa Acciaio Inox
- Girante Acciaio Inox
- Griglia aspirazione Acciaio Inox
- Albero motore Acciaio Inox

OPERATING CONDITIONS

- Liquid temperature up to 35°C
- Submersion depth 5 mt.
- Grain size inlet Ø 35 mm
- Min. suction level 65 mm
- Continuous duty

MOTOR

- Dual chamber with oil bath motor for cooling and bearing lubrication
- Mechanical seal in oil bath
- Permanent split capacitor
- Insulation Class F
- Protection IP 68

MATERIALS

- Handle Stainless Steel
- Motor casing Stainless Steel
- Pump body Cast Iron (DXG 1100-1200)
- Pump body Stainless Steel
- Impeller Stainless Steel
- Suction grid Stainless Steel
- Shaft with rotor Stainless Steel



1000
1200

1100
1400

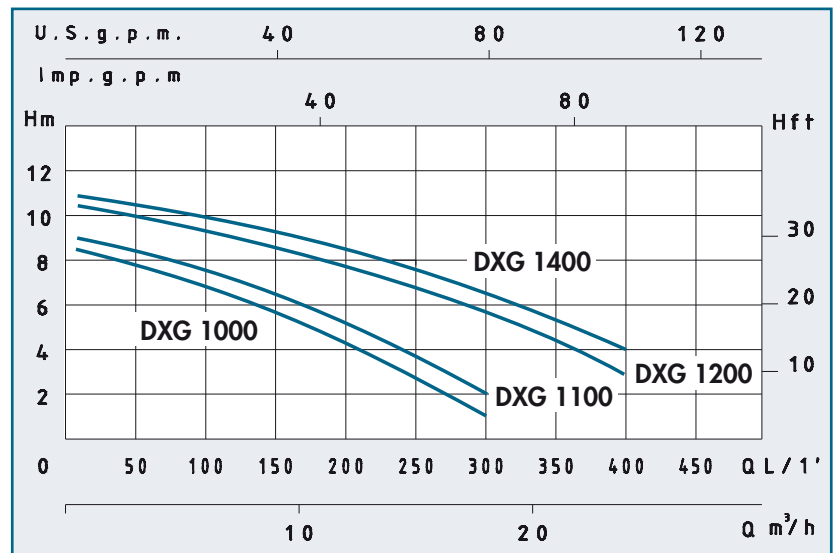

TIPO - TYPE	POTENZA ASSORBITA INPUT POWER P1	AMPERE	Q = PORTATA - CAPACITY											
			m³/h	1,8	3,6	5,4	7,2	9	12	15	18	21	24	Dimensioni Dimensions
Con galleggiante With float switch		Monofase Single-phase	lt/1'	30	60	90	120	150	200	250	300	350	400	
230V-50Hz	Watt	1 x 230V	Prevalenza manometrica totale in m.C.A. - Total head in meters w.c. DNM											
DXG 1000	1100 W	5	H (m)	7,8	7,5	7	6,2	5,8	4,2	3	1			1"1/2
DXG 1200	1400 W	6,5		8,2	8	7,5	7	6,5	5	3,9	2			2"
DXG 1100	1100 W	5		10	9,5	9,2	8,5	8	7,8	6,5	5,8	4,2	3	1"1/2
DXG 1400	1400 W	6,5		10,5	10,2	10	9,2	8,8	8,5	7,8	6,2	5	4	2"

ELETTROPOMPE SOMMERSE PER DRENAGGIO SUBMERSIBLE ELECTRIC PUMP FOR THE DRAINAGE



LIMITI D'IMPIEGO

- Temperatura liquido fino a 35° C
- Profondità d'immersione 20 mt.
- Passaggio solidi Ø 10 mm
- Livello min. d'aspiraz. 100 mm
- Servizio continuo

MOTORE

- Isolamento Classe F
- Protezione IP 68
- Protettore termico

MATERIALI

- Corpo motore Ghisa
- Corpo pompa Ghisa
- Girante Ghisa
- Albero motore Acciaio Inox
- Griglia Acciaio Inox
- Tenuta meccanica Ceramica/Grafite (a richiesta Silicio/Silicio)

OPERATING CONDITIONS

- Liquid temperature up to 35°C
- Submersion depth 20 mt.
- Grain size inlet Ø 10 mm
- Min. suction level 100 mm
- Continuous duty

MOTOR

- Insulation Class F
- Protection IP 68
- Thermic protection

MATERIALS

- Motor body Cast Iron
- Pump body Cast Iron
- Impeller Cast Iron
- Shaft with rotor Stainless Steel
- Suction strainer Stainless Steel
- Mechanical seal Ceramic/Graphite (on request Silicon/Silicon)

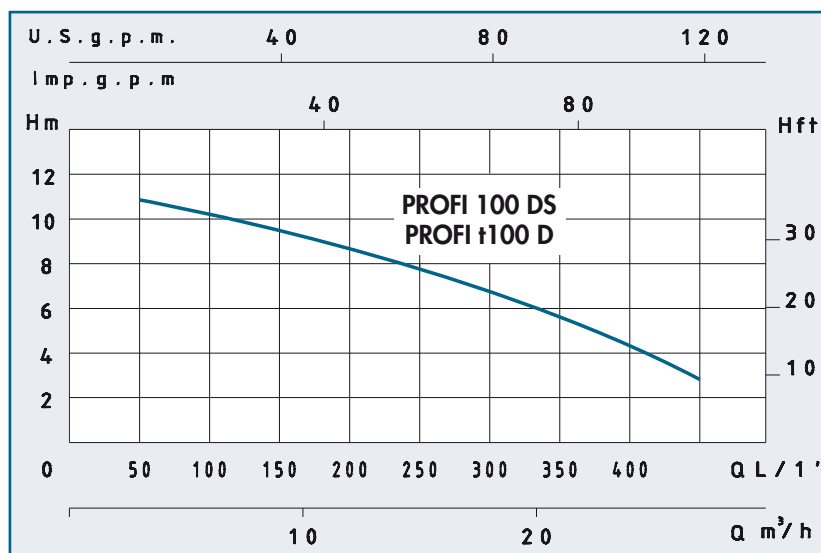

TIPO - TYPE		POTENZA NOMINALE NOMINAL POWER P2		AMPERE		Q = PORTATA - CAPACITY											
Monofase Single-phase	Trifase Three-phase	HP	kW	Monofase Single-phase	Trifase Three-phase	m³/h	3	6	9	12	15	18	21	24	27	30	Dimensioni Dimensions
230V-50Hz	230/400V-50Hz			1 x 230V	3 x 400V	lt/1'	50	100	150	200	250	300	350	400	450	500	
PROFI 100 DS	PROFI t 100 D	1	0,75	4,8	2,2	H (m)	11	10,5	10	9	8	7	6	4,5	3		1"1/2

ELETTROPOMPE SOMMERSE CON GIRANTE VORTEX SUBMERSIBLE PUMPS WITH VORTEX IMPELLER



LIMITI D'IMPIEGO

- Temperatura liquido fino a 35° C
- Profondità d'immersione 20 mt.
- Passaggio solidi Ø 30 mm
- Livello min. d'aspiraz. 100 mm
- Servizio continuo

MOTORE

- Isolamento Classe F
- Protezione IP 68
- Protettore termico

MATERIALI

- Corpo motore Ghisa
- Corpo pompa Ghisa
- Girante Ghisa
- Albero motore Acciaio Inox
- Tenuta meccanica Ceramica/Grafite
(a richiesta Silicio/Silicio)

OPERATING CONDITIONS

- Liquid temperature up to 35°C
- Submersion depth 20 mt.
- Grain size inlet Ø 30 mm
- Min. suction level 100 mm
- Continuous duty

MOTOR

- Insulation Class F
- Protection IP 68
- Thermic protection

MATERIALS

- Motor body Cast Iron
- Pump body Cast Iron
- Impeller Cast Iron
- Shaft with rotor Stainless Steel
- Mechanical seal Ceramic/Graphite
(on request Silicon/Silicon)

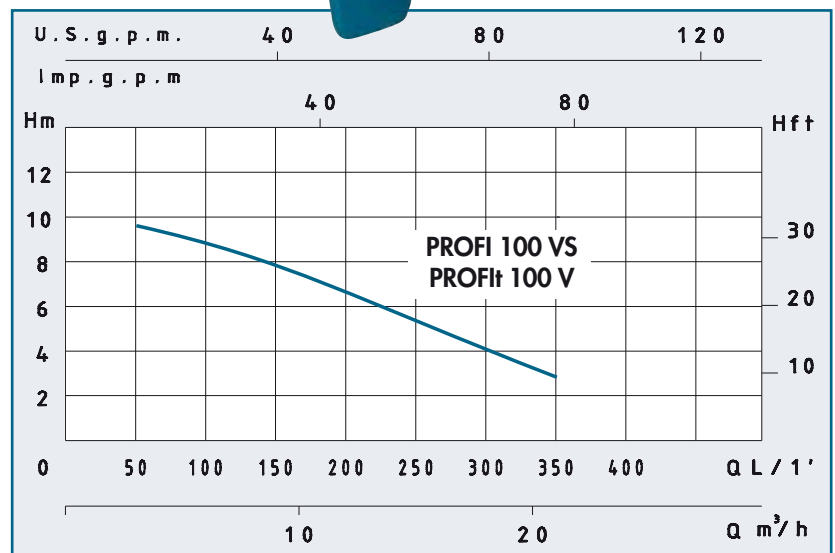

TIPO - TYPE		POTENZA NOMINALE NOMINAL POWER P2		AMPERE		Q = PORTATA - CAPACITY											
Monofase Single-phase	Trifase Three-phase	HP	kW	Monofase Single-phase	Trifase Three-phase	m³/h	3	6	9	12	15	18	21	24	27	30	Dimensioni Dimensions
230V-50Hz	230/400V-50Hz			1 x 230V	3 x 400V	lt/1'	50	100	150	200	250	300	350	400	450	500	
PROFI 100 VS	PROFIt 100 V	1	0,75	4,8	2,2	H (m)	9,5	9	8	6,5	5	4	3				2"

ELETTROPOMPE SOMMERSE CON GIRANTE VORTEX SUBMERSIBLE PUMPS WITH VORTEX IMPELLER

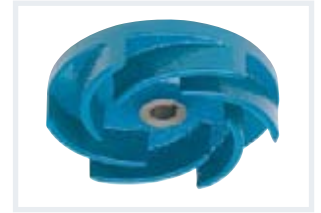

**INCLUSO NEI MODELLI
MONOFASE**
INCLUDED IN THE
SINGLE-PHASE MODELS



LIMITI D'IMPIEGO

- Temperatura liquido fino a 60° C
- Profondità d'immersione 20 mt.
- Passaggio solidi Ø 40 mm
- Livello min. d'aspiraz. 125 mm
- Servizio continuo

MOTORE

- Isolamento Classe F
- Protezione IP 68
- Protettore termico

MATERIALI

- Corpo motore Ghisa
- Corpo pompa Ghisa
- Girante Ghisa
- Albero motore Acciaio Inox
- Tenuta meccanica doppia
Silicio/Silicio + Ceramica/Grafite

OPERATING CONDITIONS

- Liquid temperature up to 60°C
- Submersion depth 20 mt.
- Grain size inlet Ø 40 mm
- Min. suction level 125 mm
- Continuous duty

MOTOR

- Insulation Class F
- Protection IP 68
- Thermic protection

MATERIALS

- Motor body Cast Iron
- Pump body Cast Iron
- Impeller Cast Iron
- Shaft with rotor Stainless Steel
- Double mechanical seal
Silicon/Silicon + Ceramic/Graphite

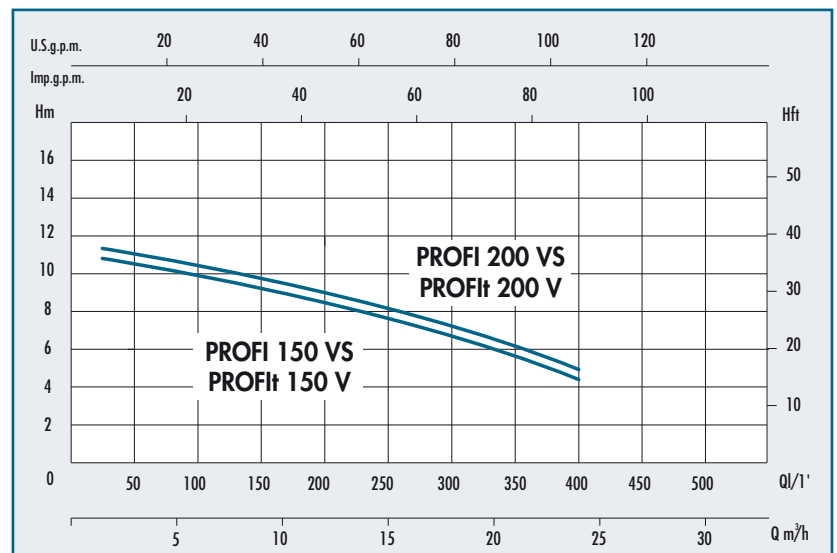

TIPO - TYPE		POTENZA NOMINALE NOMINAL POWER P2		AMPERE		Q = PORTATA - CAPACITY											
Monofase Single-phase	Trifase Three-phase	HP	kW	Monofase Single-phase	Trifase Three-phase	m³/h	3	6	9	12	18	24	30	36	42	48	Dimensioni Dimensions
230V-50Hz	230/400V-50Hz			1 x 230V	3 x 400V	lt/1'	50	100	150	200	300	400	500	600	700	800	
PROFI 150 VS	PROFI 150 V	1,5	1,1	7,5	3,2	H	11	10	9	8	6	4					2"
PROFI 200 VS	PROFI 200 V	2	1,5	8,5	3,5	(m)	11,5	11	10	9	7	5					2"

ELETTROPOMPE SOMMERSE CON GIRANTE VORTEX SUBMERSIBLE PUMPS WITH VORTEX IMPELLER

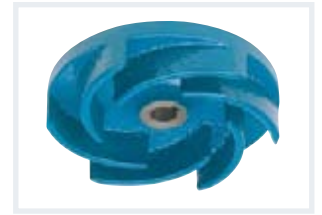

**INCLUSO NEI MODELLI
MONOFASE**
INCLUDED IN THE
SINGLE-PHASE MODELS



LIMITI D'IMPIEGO

- Temperatura liquido fino a 60° C
- Profondità d'immersione 20 mt.
- Passaggio solidi Ø 50 mm
- Livello min. d'aspiraz. 140 mm
- Servizio continuo

MOTORE

- Isolamento Classe F
- Protezione IP 68
- Protettore termico

MATERIALI

- Corpo motore Ghisa
- Corpo pompa Ghisa
- Girante Ghisa
- Albero motore Acciaio Inox
- Tenuta meccanica doppia Silicio/Silicio + Ceramica/Grafite

OPERATING CONDITIONS

- Liquid temperature up to 60°C
- Submersion depth 20 mt.
- Grain size inlet Ø 50 mm
- Min. suction level 140 mm
- Continuous duty

MOTOR

- Insulation Class F
- Protection IP 68
- Thermic protection

MATERIALS

- Motor body Cast Iron
- Pump body Cast Iron
- Impeller Cast Iron
- Shaft with rotor Stainless Steel
- Double mechanical seal Silicon/Silicon + Ceramic/Graphite

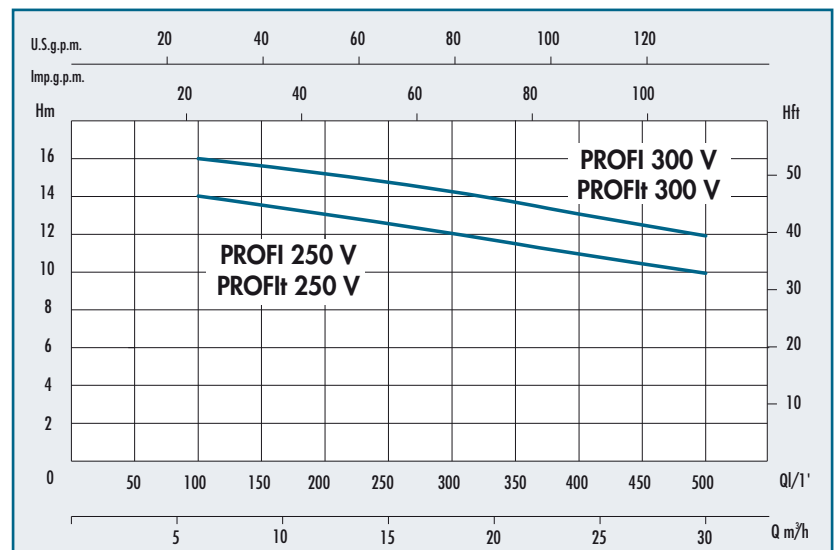

TIPO - TYPE		POTENZA NOMINALE NOMINAL POWER P2		AMPERE		Q = PORTATA - CAPACITY											
Monofase Single-phase	Trifase Three-phase	HP	kW	Monofase Single-phase	Trifase Three-phase	m³/h	3	6	9	12	18	24	30	36	42	48	Dimensioni Dimensions
230V-50Hz	230/400V-50Hz			1 x 230V	3 x 400V	lt/1'	50	100	150	200	300	400	500	600	700	800	
PROFI 250 V	PROFIt 250 V	2,5	1,85	11	4,6	H	15	14	13,5	13	12	11	9	7			2"1/2
PROFI 300 V	PROFIt 300 V	3	2,2	14	5,5	(m)	17	16	15,5	15	14	13	11	9			2"1/2

ELETTROPOMPE SOMMERSE CON GIRANTE VORTEX SUBMERSIBLE PUMPS WITH VORTEX IMPELLER

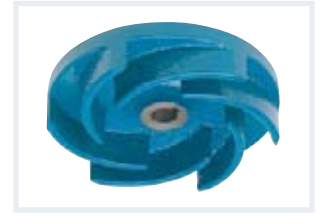

LIMITI D'IMPIEGO

- Temperatura liquido fino a 60° C
- Profondità d'immersione 20 mt.
- Passaggio solidi Ø 70 mm
- Livello min. d'aspiraz. 190 mm
- Servizio continuo

MOTORE

- Isolamento Classe F
- Protezione IP 68
- Protettore termico

MATERIALI

- Corpo motore Ghisa
- Corpo pompa Ghisa
- Girante Ghisa
- Albero motore Acciaio Inox
- Tenuta meccanica doppia Silicio/Silicio + Ceramica/Grafite

OPERATING CONDITIONS

- Liquid temperature up to 60°C
- Submersion depth 20 mt.
- Grain size inlet Ø 70 mm
- Min. suction level 190 mm
- Continuous duty

MOTOR

- Insulation Class F
- Protection IP 68
- Thermic protection

MATERIALS

- Motor body Cast Iron
- Pump body Cast Iron
- Impeller Cast Iron
- Shaft with rotor Stainless Steel
- Double mechanical seal Silicon/Silicon + Ceramic/Graphite

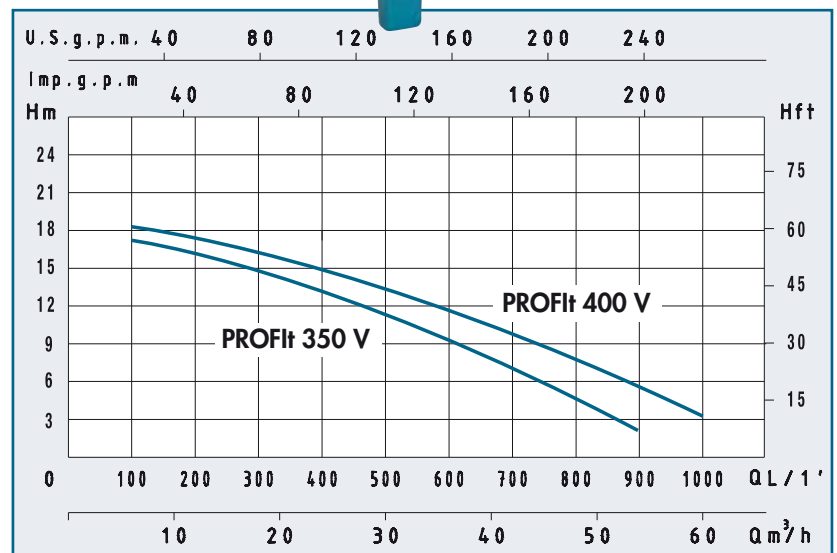

TIPO - TYPE	POTENZA NOMINALE		AMPERE	Q = PORTATA - CAPACITY											
	NOMINAL POWER P2			Trifase Three-phase	m³/h	6	12	18	24	30	36	42	48	54	60
Trifase Three-phase	HP	kW	3 x 400V		lt/1'	100	200	300	400	500	600	700	800	900	1000
230/400V-50Hz				Prevalenza manometrica totale in m.C.A. - Total head in meters w.c.											
PROFIT 350 V	3,5	2,5	6	H (m)	17	16	15	13	11	9	7	5	2	3"	
PROFIT 400 V	4	3	6,8		18	17	16	14	13	11	9	7	4	3"	

ELETTROPOMPE SOMMERSE ACQUE LURIDE SUBMERSIBLE SEWAGE PUMPS



LIMITI D'IMPIEGO

- Temperatura liquido fino a 40°C
- Profondità d'immersione max. 5 mt.
- PH liquido da 4 a 10
- Servizio continuo a pompa completamente sommersa
- Densità liquido 1,2 Kg/dm³

MOTORE

- Isolamento Classe F
- Protezione IP 68
- Protettore termico

MATERIALI

- Corpo motore Ghisa
- Corpo pompa Ghisa
- Girante Ghisa
- Albero motore Acciaio Inox
- Tenuta meccanica Ceramica/Grafite

OPERATING CONDITIONS

- Liquid temperature up to 40°C
- Submersion depth max. 5 mt.
- Liquid PH from 4 to 10
- Continuous duty with completely submersed pump
- Liquid density 1,2 Kg/dm³

MOTOR

- Insulation Class F
- Protection IP 68
- Themic protection

MATERIALS

- Motor body Cast iron
- Pump body Cast iron
- Impeller Cast iron
- Shaft with rotor Stainless steel
- Mechanical seal Ceramic/Graphite

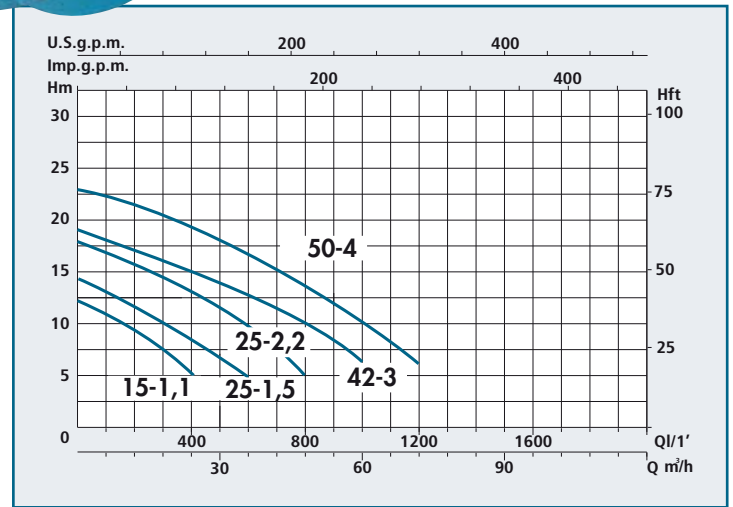
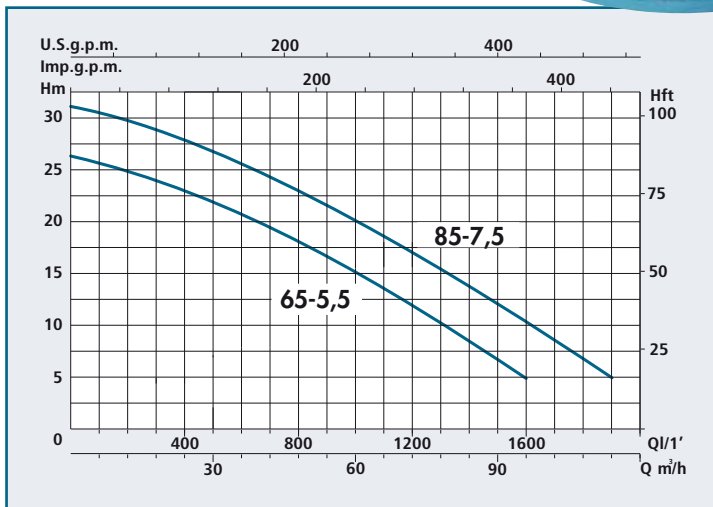

TIPO - TYPE	POTENZA NOMINALE NOMINAL POWER P2		AMPERE	Q = PORTATA - CAPACITY										
	HP	kW		Trifase Three-phase	m³/h	6	12	24	36	48	60	72	84	96
Trifase Three-phase			Trifase Three-phase	6	12	24	36	48	60	72	84	96	114	Dimensioni Dimensions
230/400V-50Hz			3 x 400V	Prevalenza manometrica totale in m.C.A. - Total head in meters w.c.										
PROFIt 15-1,1	1,5	1,1	2,9	11	8	5								2"
PROFIt 25-1,5	2	1,5	3,8	13	11	8	5							2"
PROFIt 25-2,2	3	2,2	5,4	17	16	13	8	5						2"
PROFIt 42-3	4	3	7	18	17	15	13	10	6					3"
PROFIt 50-4	5	4	9,3	22	21	19	16	13	10	6				3"
PROFIt 65-5,5	7,5	5,5	12,3	25	24	23	21	18	15	12	8	5		4"
PROFIt 85-7,5	10	7,5	16,5	31	30	28	25	23	20	18	15	11	5	4"

ELETTROPOMPA SOMMERSA PERIFERICA PER POZZI 4" PERIPHERAL TURBINE SUBMERSIBLE PUMP FOR 4" WELLS

LIMITI D'IMPIEGO

- Temperatura liquido fino a 35° C
- Profondità immersione 30 mt.
- Contenuto di sabbia 10 g/m³
- Partenza/ora 40 max.

MOTORE

- Motore elettrico ad induzione a 2 poli (n = 2850 min-1)
- Protezione termica incorporata
- Isolamento Classe F
- Protezione IP 68
- Condensatore incorporato

MATERIALI

- Bocca mandata Nylon
- Bocca mandata Ghisa nichelata (100-150)
- Flangia aspirazione Ghisa nichelata
- Fondello inferiore Nylon
- Fondello inferiore Ghisa nichelata (100-150)
- Camicia esterna Acciaio Inox
- Girante Ottone
- Filtro Acciaio
- Albero motore Inox
- Piastrine di rasamento acciaio inox
- Tenuta meccanica Acciaio Inox
Ceramica/Grafite

OPERATING CONDITIONS

- Liquid temperature up to 35°C
- Submersion depth 30m
- Sand content 10 g/m³
- Start/hour 40 max

MOTOR

- Two-Pole induction motor (n = 2850 min-1)
- Built-in overload protection
- Insulation Class F
- Protection IP 68
- Built-in capacitor

MATERIALS

- Delivery outlet Nylon
- Delivery outlet Nickered Cast Iron (100-150)
- Suction flange Nickered Cast Iron
- Bottom plate Nylon
- Bottom plate Nickered Cast Iron (100-150)
- External casing Stainless steel
- Impeller Brass
- Filter Stainless steel
- Shaft with rotor Stainless steel
- Antilocking plate Stainless steel
- Mechanical seal Ceramic/Graphite

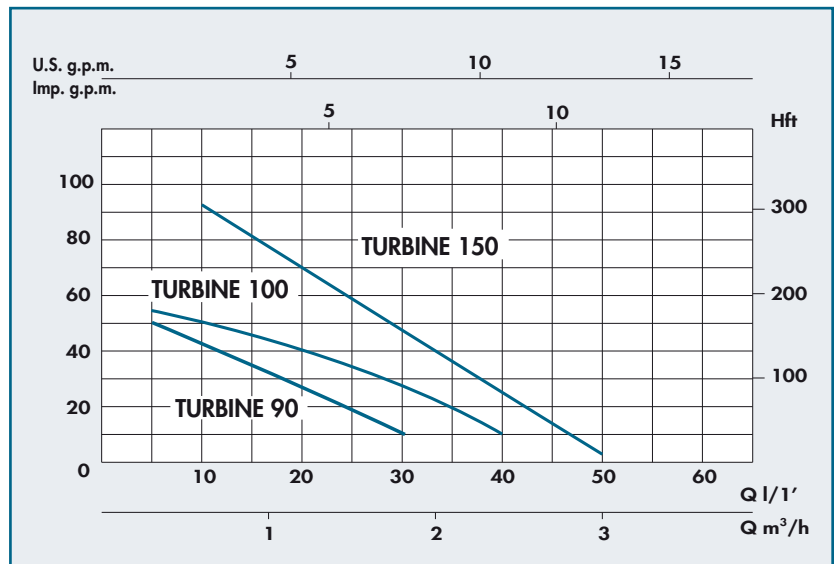

TIPO - TYPE	POTENZA NOMINALE NOMINAL POWER		AMPERE	Q = PORTATA - CAPACITY											
	HP	kW		Monofase Single-phase	m ³ /h	0,3	0,6	0,9	1,2	1,5	1,8	2,1	2,4	2,7	3
Monofase Single-phase	P2		Monofase Single-phase	0,3	0,6	0,9	1,2	1,5	1,8	2,1	2,4	2,7	3		
230V-50Hz	HP	kW	1 x 230V	Prevalenza manometrica totale in m.C.A. - Total head in meters w.c.										DNM	
TURBINE 90	0,9	0,8	4,8	45	39	32	25	18	10	3					1"
TURBINE 100	1	0,75	5,5	53	50	46	41	35	28	20	10	5	2		1"
TURBINE 150	1,5	1,1	7,9	100	91	80	70	59	47	33	25	13	3		1"

ELETTROPOMPA SOMMERSA MULTISTADIO MULTISTAGE SUBMERSIBLE PUMP



LIMITI D'IMPIEGO

- Temperatura liquido fino a 35° C
- Profondità immersione 20 mt.
- Partenza/ora 45 max.

MOTORE

- Motore elettrico ad induzione a 2 poli (n = 2850 min-1)
- Protezione amperometrica a riarmo automatico incorporata
- Isolamento Classe F
- Protezione IP 68

MATERIALI

- Corpo pompa Acciaio Inox
- Griglia Noryl
- Girante e diffusori Noryl
- Supporti Alluminio
- Albero Acciaio
- Corpo motore Alluminio
- Tenuta meccanica Ceramica/grafite

OPERATING CONDITIONS

- Liquid temperature up to 35°C
- Submersion depth 20m
- Start/hour 45 max

MOTOR

- Two-Pole induction motor (n = 2850 min-1)
- Built-in over load motor protector with automatic reset
- Insulation Class F
- Protection IP 68

MATERIALS

- External pump body Stainless Steel
- Suction strainer Noryl
- Impeller and diffusers Noryl
- Bearing brackets Aluminium
- Shaft Stainless Steel
- Motor housing Aluminium
- Mechanical seal Ceramic/Graphite

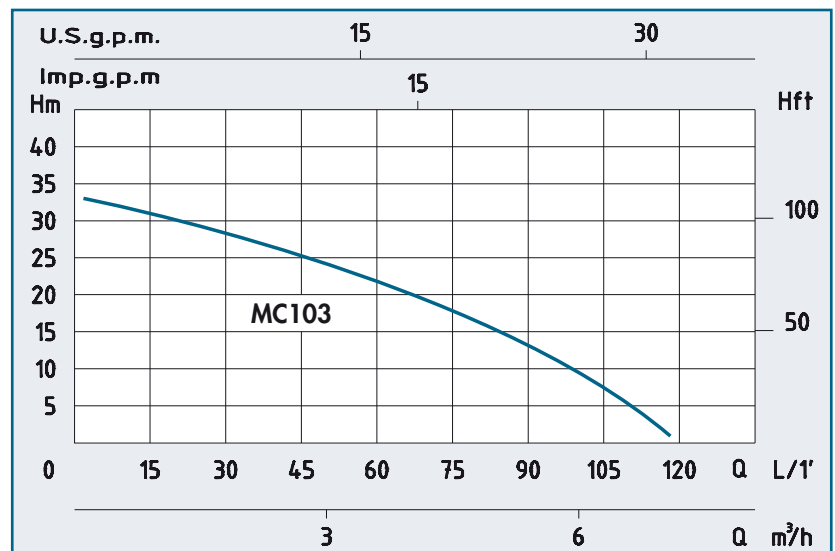

TIPO - TYPE	POTENZA NOMINALE		AMPERE	Q = PORTATA - CAPACITY											
	NOMINAL POWER P2			Monofase Single-phase	m³/h	0	0,6	1,2	1,8	2,7	3,6	4,8	5,4	6	7,2
Monofase Single-phase			Monofase Single-phase		l/1'	0	10	20	30	45	60	80	90	100	120
230V-50Hz	HP	kW	1 x 230V	Prevalenza manometrica totale in m.C.A. - Total head in meters w.c.											DNM
MC 103	0,9	0,8	3,8	H (m)	34	32	31	28	25	22	16	14	8	2	1"

ELETTROPOMPE SOMMERSE MULTISTADIO PER POZZI 6" MULTISTAGE SUBMERSIBLE PUMPS FOR 6" WELLS



LIMITI D'IMPIEGO

- Temperatura liquido fino a 35° C
- Profondità immersione 20 mt.
- Contenuto di sabbia 40 g/m³
- Partenza/ora 45 max.

OPERATING CONDITIONS

- Liquid temperature up to 35°C
- Submersion depth 20m
- Sand content 40 g/m³
- Start/hour 45 max

MOTORE

- Motore elettrico ad induzione a 2 poli (n = 2850 min-1)
- Protezione amperometrica a riarmo automatico incorporata
- Isolamento Classe F
- Protezione IP 68

MOTOR

- Two-Pole induction motor (n = 2850 min-1)
- Built-in over load motor protector with automatic reset
- Insulation Class F
- Protection IP 68

MATERIALI

- Corpo pompa Acciaio Inox
- Griglia Acciaio Inox
- Girante e diffusori Acciaio Inox
- Supporti Ghisa
- Albero Acciaio Inox
- Corpo motore Acciaio Inox
- Tenuta meccanica Silicio/Silicio

MATERIALS

- External pump body Stainless Steel
- Suction strainer Stainless Steel
- Impeller and diffusers Stainless Steel
- Bearing brackets Cast Iron
- Shaft Stainless Steel
- Motor housing Stainless Steel
- Mechanical seal Silicon/Silicon

TIPO - TYPE	POTENZA ASSORBITA INPUT POWER P1	AMPERE	Condensatore Capacitor	Q = PORTATA - CAPACITY											
				m ³ /h	0	1,5	2,5	3,5	4,5	5	6	8	10	11	Dimensioni Dimensions
Monofase Single-phase		Monofase Single-phase		lt/1'	0	25	41,6	58,3	75	83,3	100	133	166	183	
230V-50Hz	Watt	1 x 230V	µf	Prevalenza manometrica totale in m.C.A. - Total head in meters w.c.											
SUB 304	850	4,1	20	H (m)	44	39,5	33,5	25,5	16						1"1/4
SUB 305	1100	5	20		53	47	40	30	19						1"1/4
SUB 307	1350	6,3	30		76,5	67,5	57,5	46	32,5						1"1/4
SUB 604	1300	6	25		43	41	39	36,5	33	30	25,5	13			1"1/4
SUB 605	1550	7	25		53	50	48	45	40	37,5	32	15			1"1/4
SUB 606	1650	7,6	30		66	63	60	56	51,5	49	42	25			1"1/4
SUB 608	2200	10,5	35		88	84	80	75	68,5	65	56	27,5			1"1/4
SUB 904	1950	10	35		45,5	45	43	41	40	39	37	32,5	26,5	22,5	1"1/4

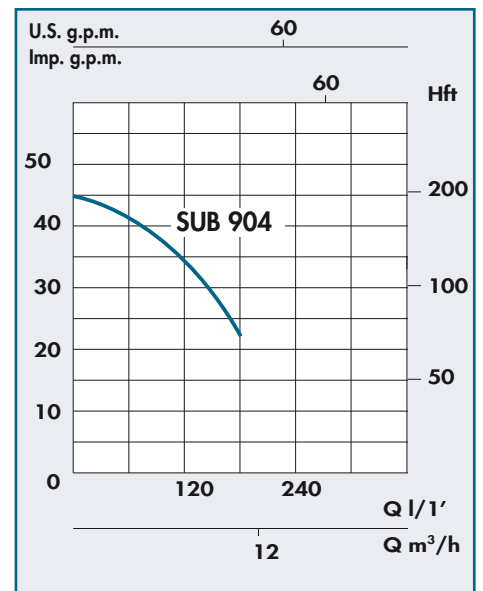
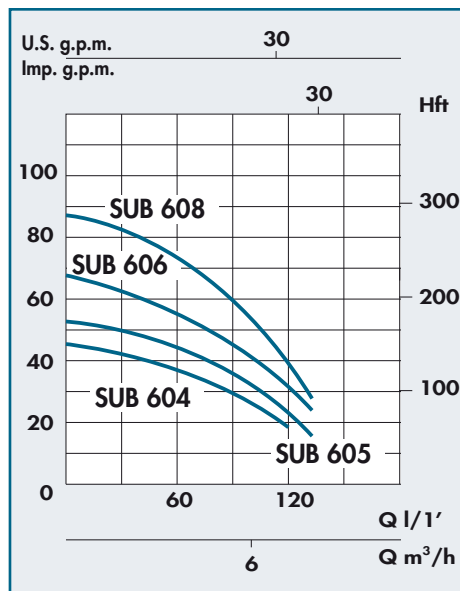
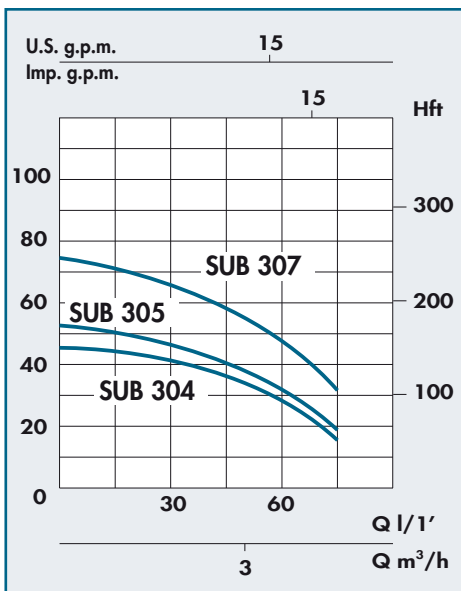



OPERATING CONDITIONS

- Liquid temperature up to 0÷40°C
- Submersion max. depth 30 mt.
- Continuous duty

MOTOR

- Insulation Class F
- Protection IP 68
- Thermic protection
- Dry type

MATERIALS

- Casing
- Upper cover
- Casing cover
- Impeller Cast
- Motor frame
- Shaft with rotor
- Double mechanical seal

Cast Iron
 Cast Iron
 Cast Iron
 Iron
 Stainless Steel
 Stainless Steel
 CA/CE (0,8÷1,3 HP)
 SIC/SIC (2÷3 HP)

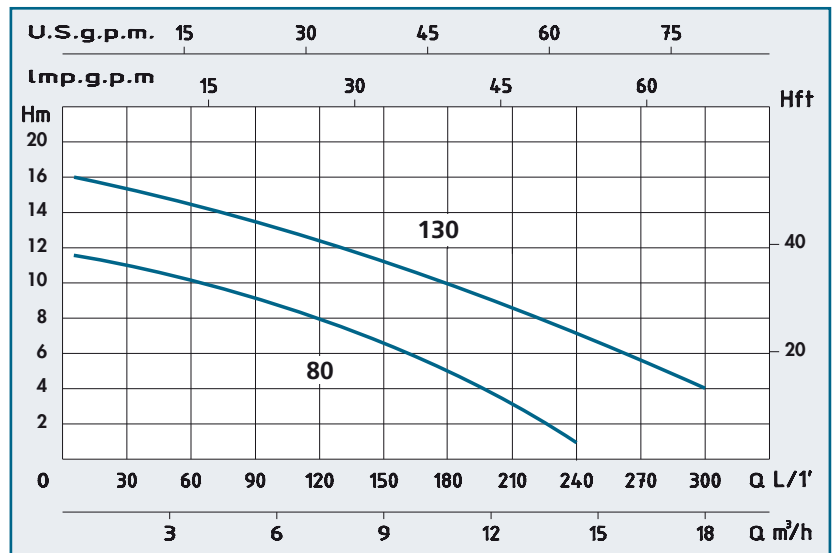

TIPO - TYPE	POTENZA NOMINALE		AMPERE	Q = PORTATA - CAPACITY											
	NOMINAL POWER P2			Monofase Single-phase	m³/h	1,8	3,6	5,4	7,2	9	12	15	18	21	24
230V-50Hz	HP	kW	1 x 230V	Prevalenza manometrica totale in m.C.A. - Total head in meters w.c.											DNM
DRAIN 80-S	0,8	0,7	3	H	11,3	10	9	8	6,3	4	1				2"
DRAIN 130-S	1,3	1,2	4,8	(m)	14,7	14,2	13,5	12,1	11	9	7	4	1		2"

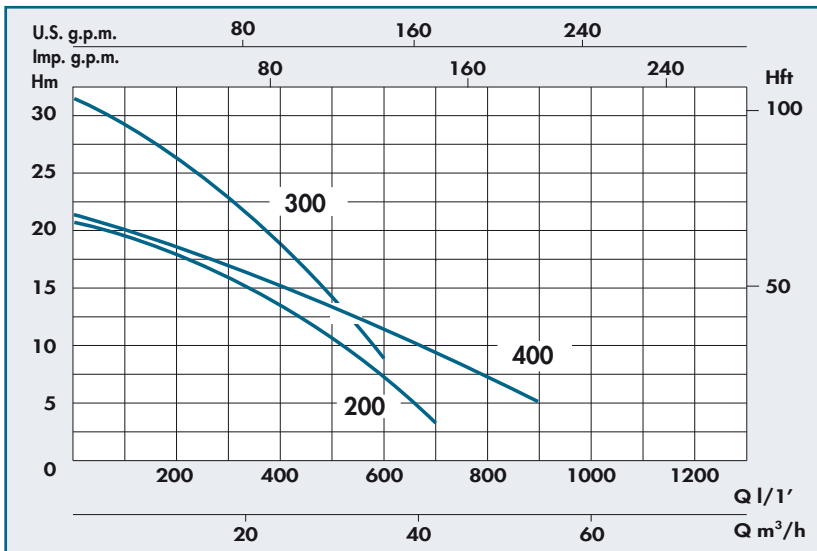
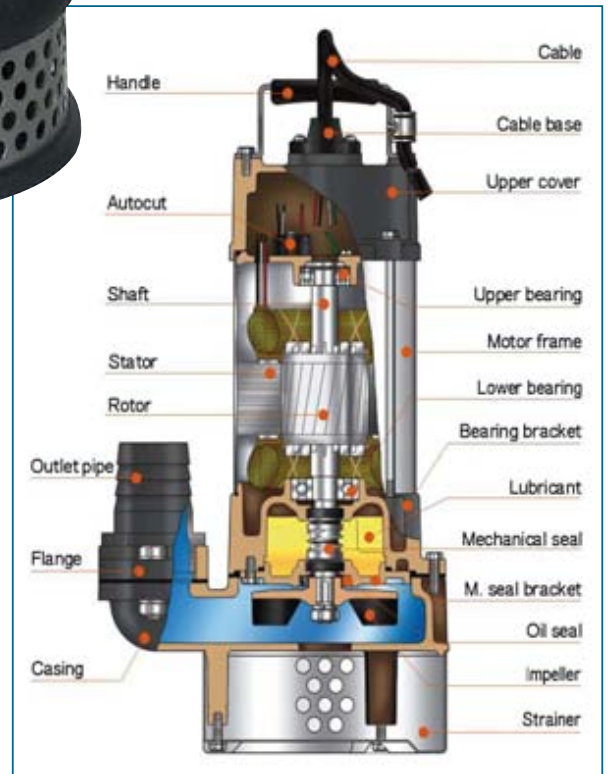

TIPO - TYPE		POTENZA NOMINALE NOMINAL POWER P2		AMPERE		Q = PORTATA - CAPACITY											
Monofase Single-phase	Trifase Three-phase	HP	kW	Monofase Single-phase	Trifase Three-phase	m³/h	1	3	6	12	24	30	36	42	48	54	Dimensioni Dimensions
230V-50Hz	230/400V-50Hz			1 x 230V	3 x 400V	lt/1'	16,6	50	100	200	400	500	600	700	800	900	
DRAIN 200-S	DRAIN 200 †	2	1,5	8,5	3,5	H (m)	21	20	19	18	12	9	6	3			3"
DRAIN 300-S	DRAIN 300 †	3	2,2	14	5,5		32,2	31,3	29,9	26,7	18	12	8				2"
	DRAIN 400 †	3	2,2		5,5		21,6	20,9	19,9	18,6	15	13	12	10	8	5	4"



OPERATING CONDITIONS

- Liquid temperature up to 0÷40°C
- Submersion max. depth 30 mt.
- Continuous duty

MOTOR

- Insulation Class F
- Protection IP 68
- Thermic protection
- Dry type

MATERIALS

- Casing
- Upper cover
- Casing cover
- Impeller Cast
- Motor frame
- Shaft with rotor
- Double mechanical seal

Cast Iron
 Cast Iron
 Cast Iron
 Iron
 Stainless Steel
 Stainless Steel
 CA/CE (0,8÷1,3 HP)
 SIC/SIC (2÷3 HP)

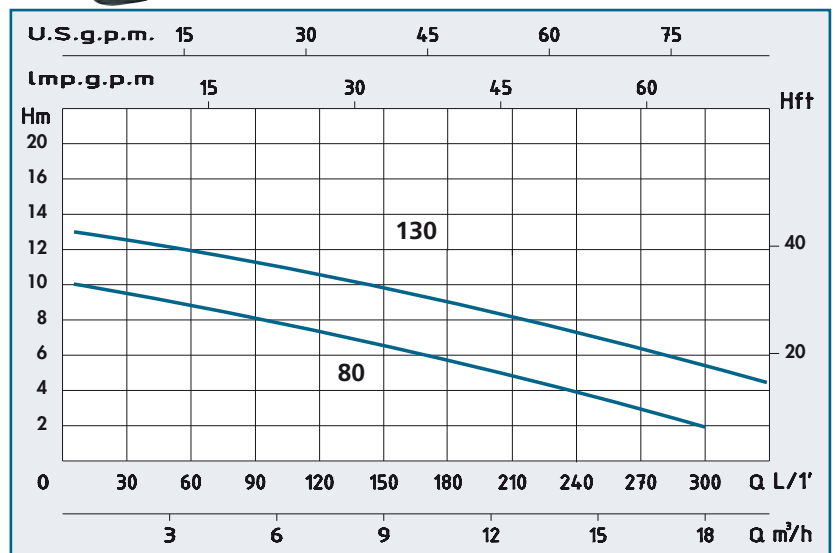

TIPO - TYPE		POTENZA NOMINALE NOMINAL POWER P2		AMPERE		Q = PORTATA - CAPACITY											
Monofase Single-phase	Trifase Three-phase	HP	kW	Monofase Single-phase	Trifase Three-phase	m³/h	1,8	3,6	5,4	7,2	9	12	15	18	21	24	Dimensioni Dimensions
230V-50Hz	230/400V-50Hz			1 x 230V	3 x 400V	lt/1'	30	60	90	120	150	200	250	300	350	400	
VORT 80-S		0,8	0,7	3		H	9,4	9	8	7	6,2	5	4	2			2"
VORT 130-S	VORT 130 †	1,3	1,2	4,8	1,9	(m)	13	12	11	10,5	10	8	7,5	8	4		2"

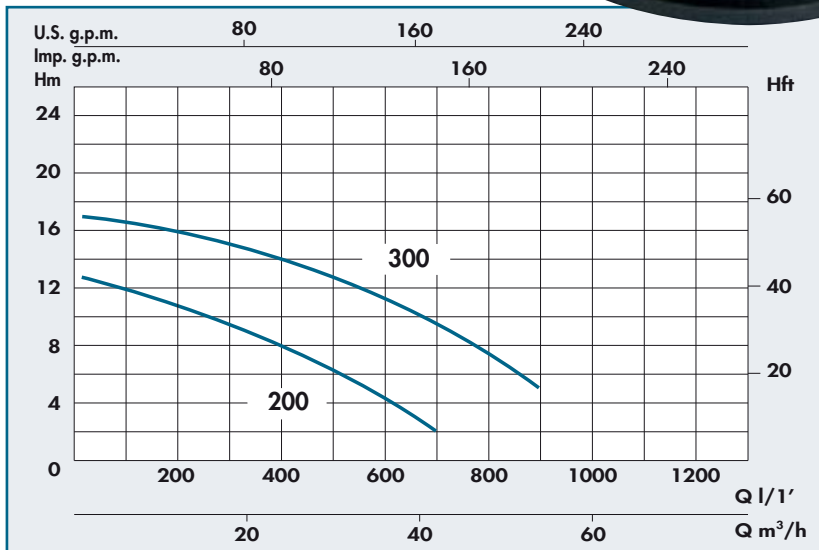

TIPO - TYPE		POTENZA NOMINALE NOMINAL POWER P2		AMPERE		Q = PORTATA - CAPACITY											
Monofase Single-phase	Trifase Three-phase	HP	kW	Monofase Single-phase	Trifase Three-phase	m³/h	1	3	6	12	24	30	36	42	48	54	Dimensioni Dimensions
						lt/1'	16,6	50	100	200	400	500	600	700	800	900	
230V-50Hz	230/400V-50Hz			1 x 230V	3 x 400V	Prevalenza manometrica totale in m.C.A. - Total head in meters w.c.										DNM	
VORT 200-S	VORT 200 †	2	1,5	8,5	3,5	H	12,5	12,3	12	11,3	8	6	3	2			3"
VORT 300-S	VORT 300 †	3	2,2	14	5,5	(m)	16,9	16,6	16,3	15,5	14	12	10	8,5	7	5	3"



OPERATING CONDITIONS

- Liquid temperature up to 0÷40°C
- Submersion max. depth 30 mt.
- Continuous duty

MOTOR

- Insulation Class F
- Protection IP 68
- Thermic protection
- Dry type

MATERIALS

- Casing
- Upper cover
- Casing cover
- Impeller
- Motor frame
- Shaft with rotor
- Double mechanical seal

Stainless Steel AISI 316
 Stainless Steel AISI 316
 Stainless Steel AISI 316
 Stainless Steel AISI 316
 Stainless Steel AISI 316
 Stainless Steel AISI 316
 Stainless Steel AISI 316
 CA/CE (0,8÷1,3 HP)
 SIC/SIC (2÷5,5 HP)

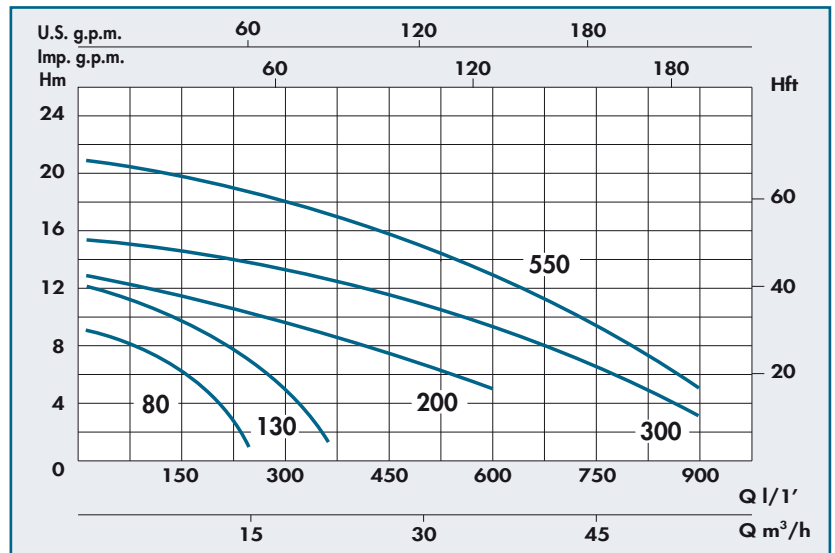

TIPO - TYPE		POTENZA NOMINALE NOMINAL POWER P2		AMPERE		Q = PORTATA - CAPACITY												
Monofase Single-phase	Trifase Three-phase	HP	kW	Monofase Single-phase	Trifase Three-phase	m³/h	1,5	3	6	8	9	12	24	36	48	54	Dimensioni Dimensions	
230V-50Hz	230/400V-50Hz			1 x 230V	3 x 400V	lt/1'	25	50	100	133	150	200	400	600	800	900		
A 316-80-S	A 316-80 †	0,8	0,7	3	1	Prevalenza manometrica totale in m.C.A. - Total head in meters w.c.											DNM	
A 316-130-S	A 316-130 †	1,3	1,2	4,8	1,9	H (m)	9,2	8,5	7,3	6,3	6,1	5					2"	
	A 316-200 †	2	1,5		3,5		12	11,7	10,5	9,7	9,2	8	2					2"
	A 316-300 †	3	2,2		5,5		12,5	11,9	11,4	11,1	10,9	10,5	9	5,4				3"
	A 316-550 †	5,5	4		12,2		15,7	15,4	15	14,6	14,4	14,2	13	9	5	3		3"
							21,0	20,5	20	19,8	19,6	19	16,8	13,8	8	5		3"



300



150



OPERATING CONDITIONS

- Liquid temperature up to 0=40°C
- Continuous duty

MOTOR

- Insulation Class F
- Protection IP 68
- Thermic protection
- Dry type

MATERIALS

- Casing Cast Iron
- Upper cover Cast Iron
- Casing cover Cast Iron
- Impeller Cast Iron
- Motor frame Stainless Steel
- Shaft with rotor Stainless Steel
- Double mechanical seal Silicon Carbide

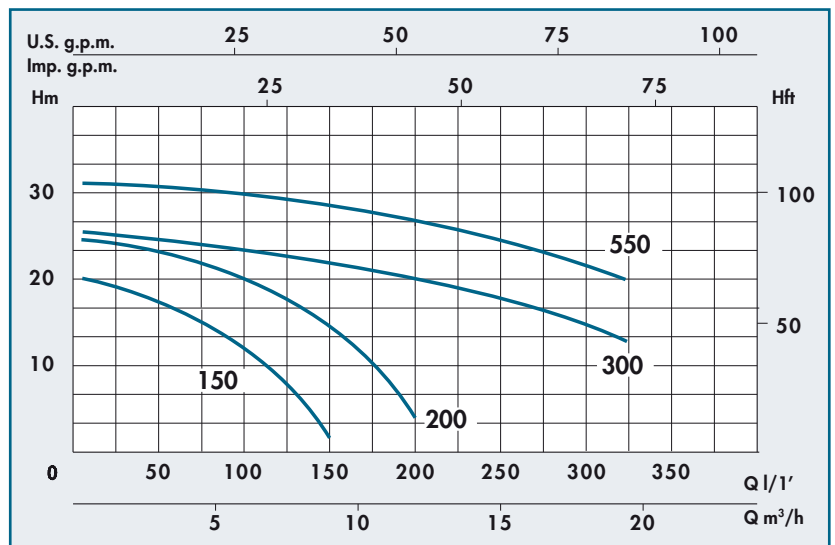

TIPO - TYPE		POTENZA NOMINALE		AMPERE		Q = PORTATA - CAPACITY												
Monofase Single-phase	Trifase Three-phase	NOMINAL POWER P2		Monofase Single-phase	Trifase Three-phase	m³/h	1,5	3	6	8	9	12	15	16	18	19	Dimensioni Dimensions	
		HP	kW			1 x 230V	3 x 400V	lt/1'	25	50	100	133,3	150	200	250	266,6		300
230V-50Hz	230/400V-50Hz			1 x 230V	3 x 400V	Prevalenza manometrica totale in m.C.A. - Total head in meters w.c.											DNM	
GRINDER 150-S	GRINDER 150 †	1,5	1,1	7,5	3,2	H (m)	20,0	18,1	12,1	8	2						1"1/4	
GRINDER 200-S	GRINDER 200 †	2	1,5	8,5	3,5		24,9	23,8	20,3	13,0	10	4						1"1/4
	GRINDER 300 †	3	2,2		5,5		25,1	25,2	24,4	23,3	22,5	20	16	15	13	12		2"
	GRINDER 550 †	5,5	4		12,2		31,3	31,2	30,4	29,1	28,4	26	24	23	21	20		2"



OPERATING CONDITIONS

- Liquid temperature up to 0÷40°C
- Submersion max. depth 30 mt.
- Continuous duty

MOTOR

- Insulation Class F
- Protection IP 68
- Thermic protection
- Dry type

MATERIALS

- Casing Cast Iron
- Upper cover Cast Iron
- Out cover Stainless Steel
- Casing cover Cast Iron
- Impeller High Chrome
- Motor frame Stainless Steel
- Shaft with rotor Stainless Steel
- Double mechanical seal SiC/SiC

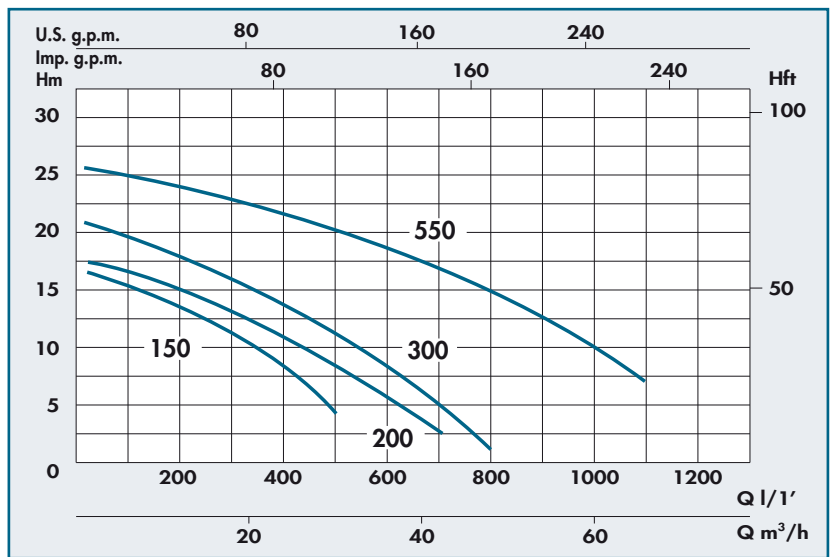

TIPO - TYPE		POTENZA NOMINALE NOMINAL POWER P2		AMPERE		Q = PORTATA - CAPACITY											Dimensioni Dimensions	
Monofase Single-phase	Trifase Three-phase	HP	kW	Monofase Single-phase	Trifase Three-phase	m³/h	6	12	18	30	36	42	48	54	60	66		
230V-50Hz	230/400V-50Hz			1 x 230V	3 x 400V	lt/1'	100	200	300	500	600	700	800	900	1000	1100		
AS 150-S		1,5	1,1	7,3		H (m)	16	14	10,5	4							2"	
AS 200-S	AS 200 †	2	1,5	9,6	3,4		17	15	13	8	5,2	2						3"
	AS 300 †	3	2,2		5,5		20,9	18,7	16,7	11,4	9,2	5	2					3"
	AS 550 †	5,5	4		12,2		25,5	24	22,2	18,9	17,1	15,2	13,3	12	9	6,2		3"



OPERATING CONDITIONS

- Liquid temperature up to 0÷40°C
- Submersion max. depth 30 mt.
- Continuous duty

MOTOR

- Insulation Class F
- Protection IP 68
- Thermic protection
- Dry type

MATERIALS

- Casing Cast Iron
- Upper cover Cast Iron
- Out cover Stainless Steel
- Casing cover Cast Iron
- Impeller High Chrome
- Motor frame Stainless Steel
- Shaft with rotor Stainless Steel
- Double mechanical seal SIC/SIC

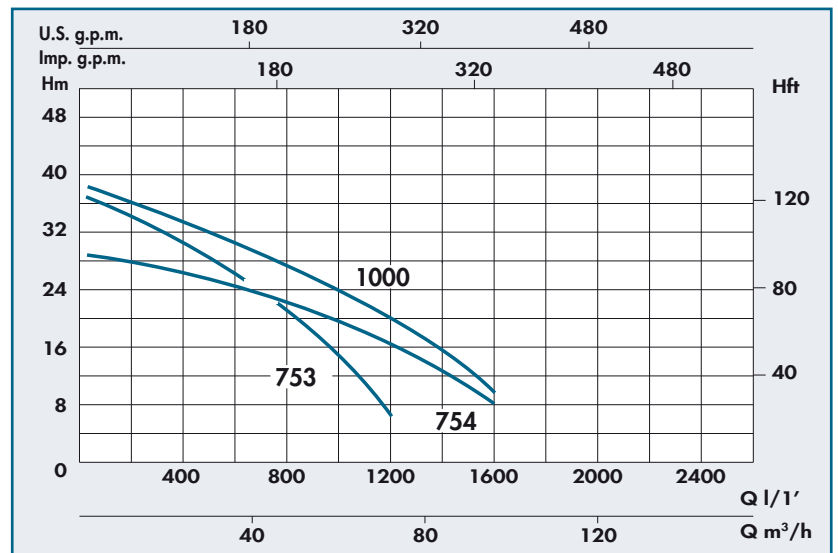

TIPO - TYPE	POTENZA NOMINALE NOMINAL POWER P2		AMPERE	Q = PORTATA - CAPACITY											
	HP	kW		Trifase Three-phase	m³/h	6	18	36	48	60	72	78	84	90	96
Trifase Three-phase				l/1'	100	300	600	800	1000	1200	1300	1400	1500	1600	
230/400V-50Hz			3 x 400V	Prevalenza manometrica totale in m.C.A. - Total head in meters w.c. DNM											
ASt 753	7,5	5,5	13,2	H (m)	36,3	32,7	26,3	21,8	16,7	7					3"
ASt 754	7,5	5,5	13,2		28,3	26,7	23,7	21,3	19	16	15	14	12	8	4"
ASt 1000	10	7,5	15		37,9	35	30,9	28	25	20	17	15	13	9	4"

ELETTROPOMPE ORIZZONTALI CENTRIFUGHE MULTISTADIO HORIZONTAL MULTISTAGE CENTRIFUGAL PUMPS

OPERATING CONDITIONS

- Max working pressure: 10 bar
- Liquid temperature up to 90°C
- Ambient temperature up to 40°C
- Total suction lift up to 7 mt.
- Continuous duty

MATERIALS

- | | |
|--------------------|-----------------|
| - Pump body | Cast Iron |
| - Motor support | Stainless Steel |
| - Impeller | Stainless Steel |
| - Diffusers | Stainless Steel |
| - Pump casing | Cast Iron |
| - Shaft with rotor | Stainless Steel |
| - Mechanical seal | Silicon Carbon |

MOTOR

- Two-Pole induction motor
($n = 2850 \text{ min}^{-1}$)
- Insulation Class F
- Protection IP 44

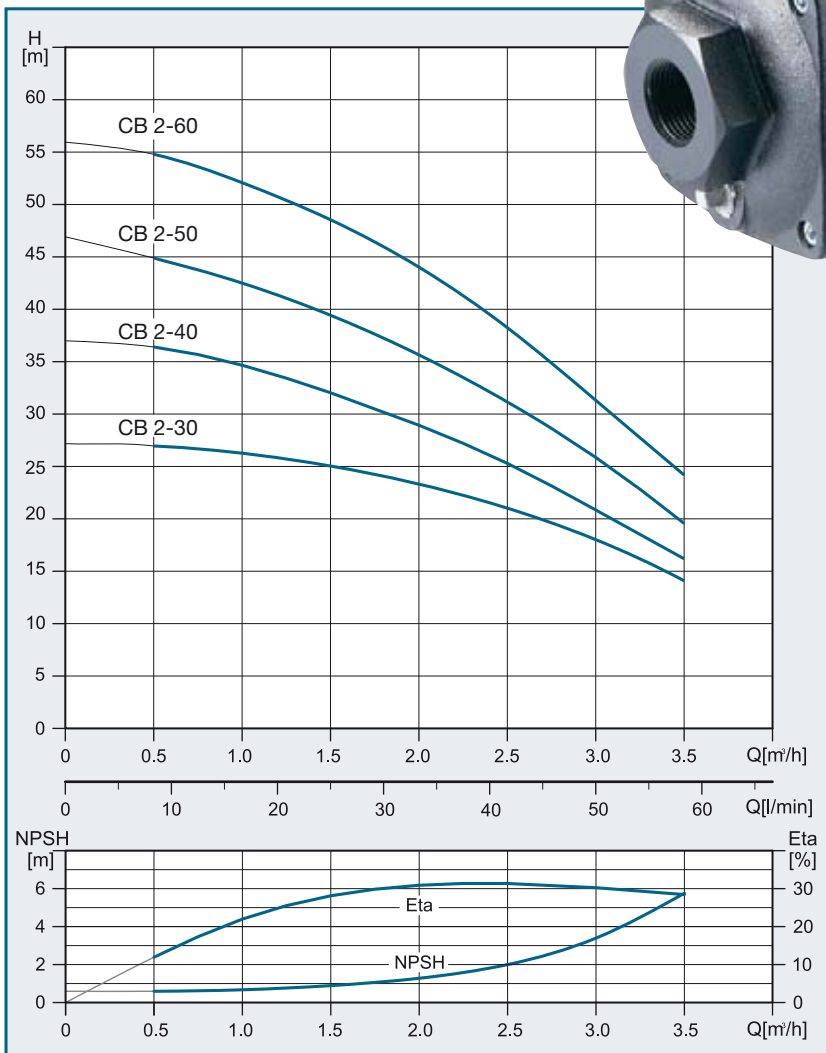

TIPO - TYPE	DNA	DNM
CB 2-30	1"	1"
CB 2-40	1"	1"
CB 2-50	1"	1"
CB 2-60	1"	1"

TIPO - TYPE	HP	Monofase - Single-phase 1 x 230 V		Trifase - Three-phase 3 x 230/400 V	
		P ₁ [W]	I _{1/1} [A]	P ₁ [W]	I _{1/1} [A]
CB 2-30	0,5	480	2,3	460	1,9 / 1,2
CB 2-40	0,5	570	2,6	560	2,0 / 1,2
CB 2-50	0,75	680	3,2	660	2,7 / 1,6
CB 2-60	0,75	810	3,7	810	2,8 / 1,6

ELETTROPOMPE ORIZZONTALI CENTRIFUGHE MULTISTADIO HORIZONTAL MULTISTAGE CENTRIFUGAL PUMPS

OPERATING CONDITIONS

- Max working pressure: 10 bar
- Liquid temperature up to 90°C
- Ambient temperature up to 40°C
- Total suction lift up to 7 mt.
- Continuous duty

MOTOR

- Two-Pole induction motor
($n = 2850 \text{ min}^{-1}$)
- Insulation Class F
- Protection IP 44

MATERIALS

- Pump body: Cast Iron
- Motor support: Stainless Steel
- Impeller: Stainless Steel
- Diffusers: Stainless Steel
- Pump casing: Cast Iron
- Shaft with rotor: Stainless Steel
- Mechanical seal: Silicon Carbon

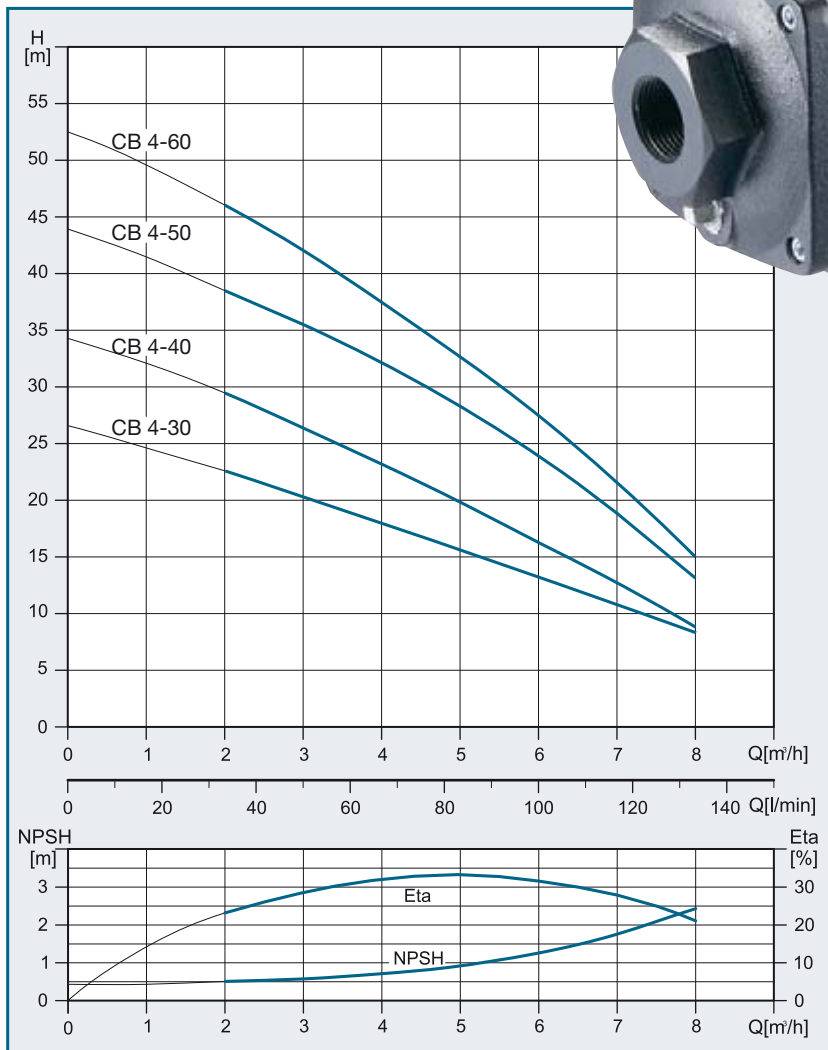

TIPO - TYPE	DNA	DNM
CB 4-30	1" 1/4	1"
CB 4-40	1" 1/4	1"
CB 4-50	1" 1/4	1"
CB 4-60	1" 1/4	1"

TIPO - TYPE	HP	Monofase - Single-phase 1 x 230 V		Trifase - Three-phase 3 x 230/400 V	
		P ₁ [W]	I _{1/1} [A]	P ₁ [W]	I _{1/1} [A]
CB 4-30	0,5	820	3,5	770	2,3 / 1,3
CB 4-40	0,75	1020	4,3	1000	3,1 / 1,8
CB 4-50	1	1220	5,4	1200	4,0 / 2,3
CB 4-60	1,5	1450	6,2	1400	4,6 / 2,7

ELETTROPOMPE ORIZZONTALI CENTRIFUGHE MULTISTADIO HORIZONTAL MULTISTAGE CENTRIFUGAL PUMPS

OPERATING CONDITIONS

- Max working pressure: 10 bar
- Liquid temperature up to 110°C
- Ambient temperature up to 40°C
- Total suction lift up to 7 mt.
- Continuous duty

MATERIALS

- Pump body: Stainless Steel
- Motor support: Stainless Steel
- Impeller: Stainless Steel
- Diffusers: Stainless Steel
- Pump casing: Stainless Steel
- Shaft with rotor: Stainless Steel
- Mechanical seal: Silicon Carbon

MOTOR

- Two-Pole induction motor ($n = 2850 \text{ min}^{-1}$)
- Insulation Class F
- Protection IP 44

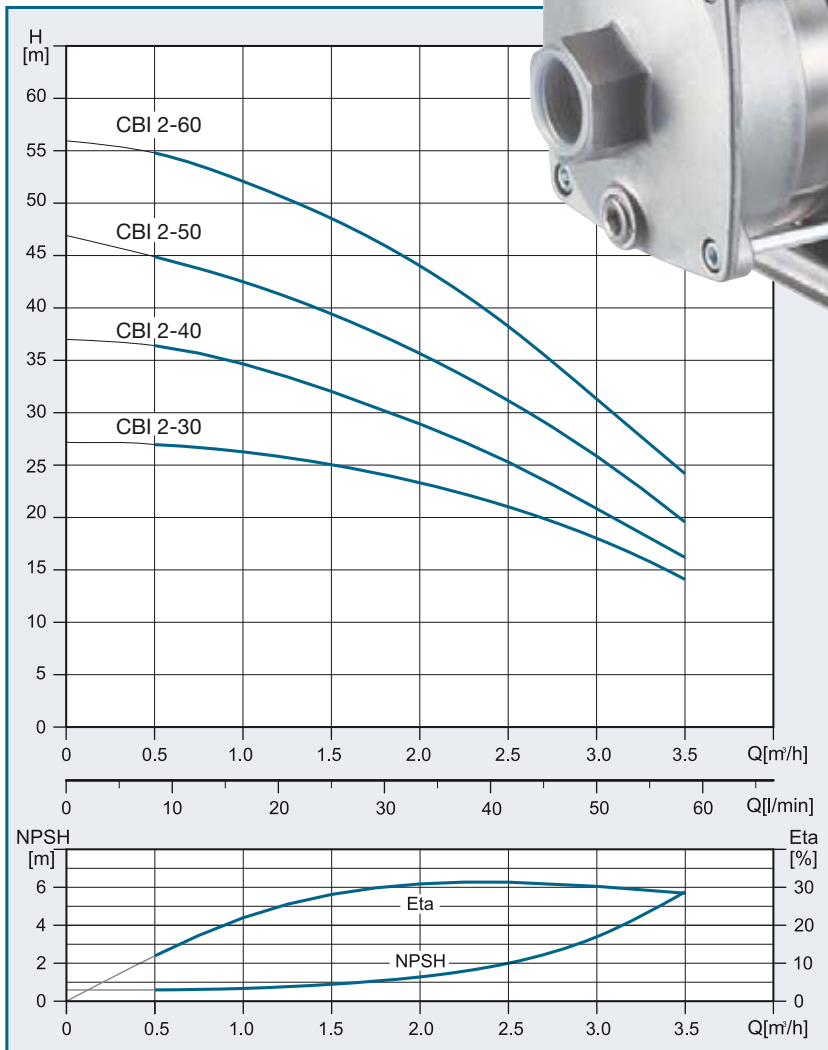

TIPO - TYPE	DNA	DNM
CBI 2-30	1"	1"
CBI 2-40	1"	1"
CBI 2-50	1"	1"
CBI 2-60	1"	1"

TIPO - TYPE	HP	Monofase - Single-phase 1 x 230 V		Trifase - Three-phase 3 x 230/400 V	
		P ₁ [W]	I _{1/1} [A]	P ₁ [W]	I _{1/1} [A]
CBI 2-30	0,5	480	2,3	460	1,9 / 1,2
CBI 2-40	0,5	570	2,6	560	2,0 / 1,2
CBI 2-50	0,75	680	3,2	660	2,7 / 1,6
CBI 2-60	0,75	810	3,7	810	2,8 / 1,6

ELETTROPOMPE ORIZZONTALI CENTRIFUGHE MULTISTADIO HORIZONTAL MULTISTAGE CENTRIFUGAL PUMPS

OPERATING CONDITIONS

- Max working pressure: 10 bar
- Liquid temperature up to 110°C
- Ambient temperature up to 40°C
- Total suction lift up to 7 mt.
- Continuous duty

MOTOR

- Two-Pole induction motor
($n = 2850 \text{ min}^{-1}$)
- Insulation Class F
- Protection IP 44

MATERIALS

- Pump body: Stainless Steel
- Motor support: Stainless Steel
- Impeller: Stainless Steel
- Diffusers: Stainless Steel
- Pump casing: Stainless Steel
- Shaft with rotor: Stainless Steel
- Mechanical seal: Silicon Carbon

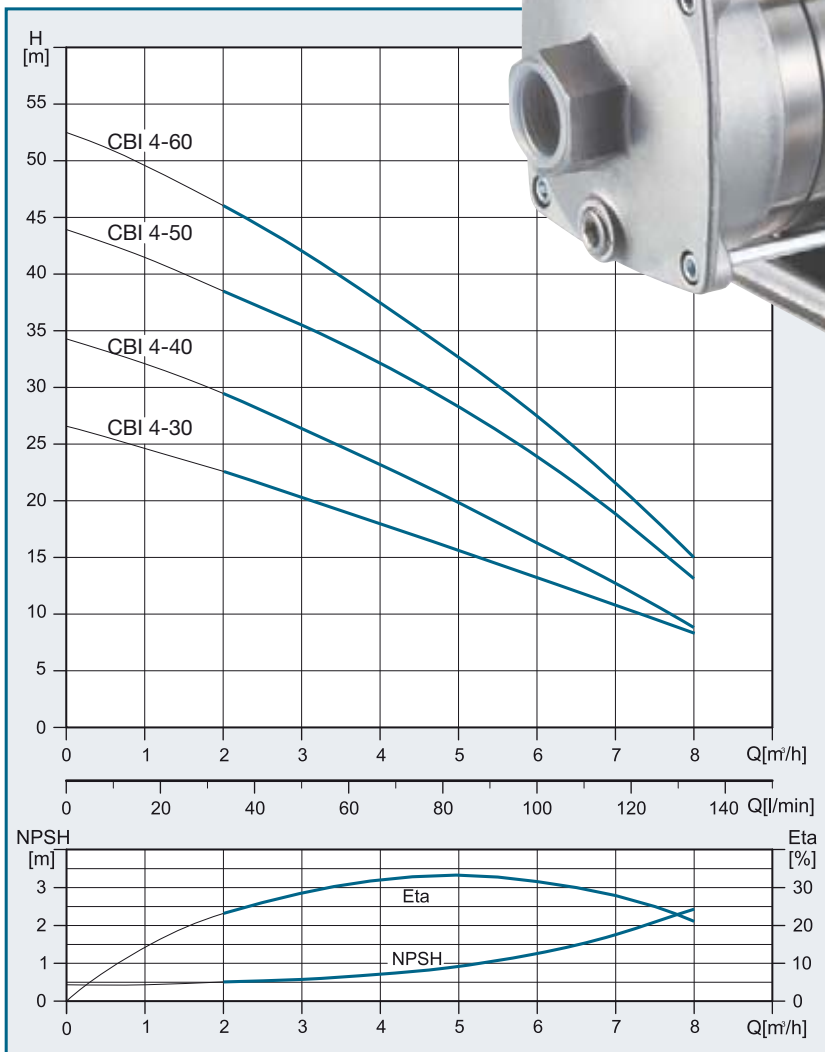

TIPO - TYPE	DNA	DNM
CBI 4-30	1" ¹ / ₄	1"
CBI 4-40	1" ¹ / ₄	1"
CBI 4-50	1" ¹ / ₄	1"
CBI 4-60	1" ¹ / ₄	1"

TIPO - TYPE	HP	Monofase - Single-phase 1 x 230 V		Trifase - Three-phase 3 x 230/400 V	
		P ₁ [W]	I _{1/1} [A]	P ₁ [W]	I _{1/1} [A]
CBI 4-30	0,5	820	3,5	770	2,3 / 1,3
CBI 4-40	0,75	1020	4,3	1000	3,1 / 1,8
CBI 4-50	1	1220	5,4	1200	4,0 / 2,3
CBI 4-60	1,5	1450	6,2	1400	4,6 / 2,7

ELETTROPOMPE ORIZZONTALI CENTRIFUGHE MULTISTADIO HORIZONTAL MULTISTAGE CENTRIFUGAL PUMPS

OPERATING CONDITIONS

- Max working pressure: 10 bar
- Liquid temperature up to 110°C
- Ambient temperature up to 40°C
- Total suction lift up to 7 mt.
- Continuous duty

MOTOR

- Two-Pole induction motor
($n = 2850 \text{ min}^{-1}$)
- Insulation Class F
- Protection IP 44

MATERIALS

- Pump body *Stainless Steel*
- Motor support *Stainless Steel*
- Impeller *Stainless Steel*
- Diffusers *Stainless Steel*
- Shaft with rotor *Stainless Steel*
- Mechanical seal *Silicon Carbon*

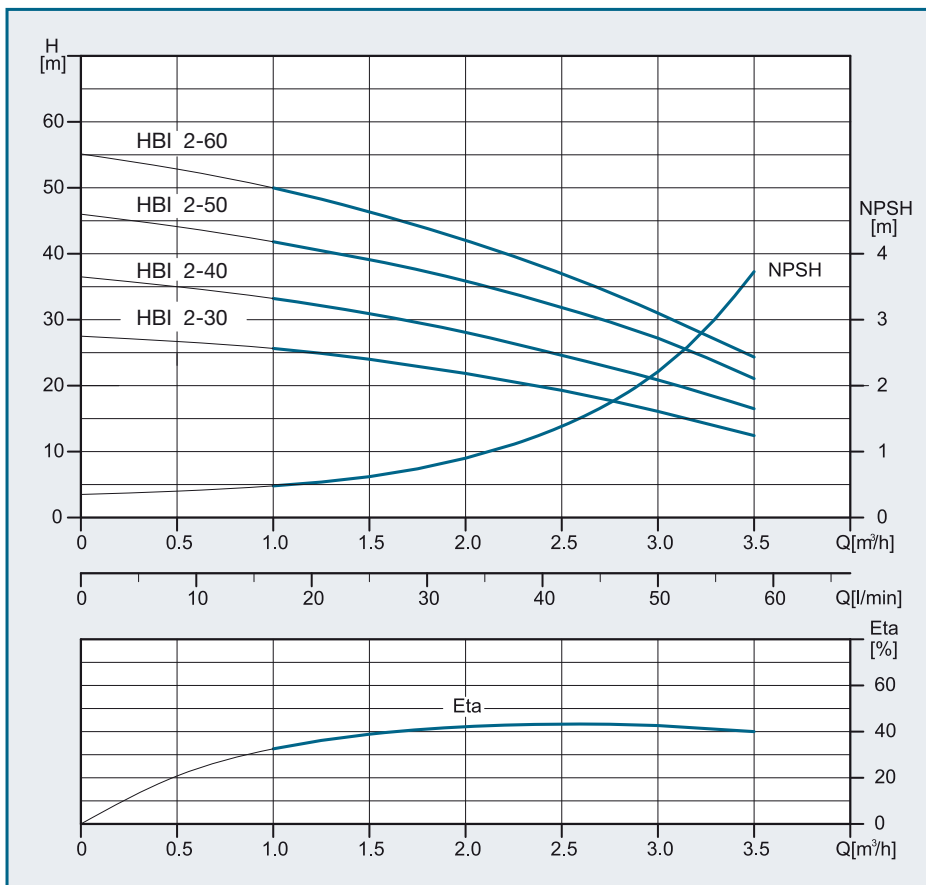

Stainless steel Aisi 304

TIPO - TYPE	DNA	DNM
HBI 2-30	1"	1"
HBI 2-40	1"	1"
HBI 2-50	1"	1"
HBI 2-60	1"	1"

TIPO - TYPE	HP	Monofase - Single-phase 1 x 230 V		Trifase - Three-phase 3 x 230/400 V	
		P ₁ [W]	I _{1/1} [A]	P ₁ [W]	I _{1/1} [A]
HBI 2-30	0,5	540	2,4	480	1,9 / 1,1
HBI 2-40	0,5	630	2,8	620	2,0 / 1,2
HBI 2-50	0,75	800	3,8	820	2,7 / 1,6
HBI 2-60	0,75	940	4,2	910	2,8 / 1,6

ELETTROPOMPE ORIZZONTALI CENTRIFUGHE MULTISTADIO HORIZONTAL MULTISTAGE CENTRIFUGAL PUMPS

OPERATING CONDITIONS

- Max working pressure: 10 bar
- Liquid temperature up to 110°C
- Ambient temperature up to 40°C
- Total suction lift up to 7 mt.
- Continuous duty

MOTOR

- Two-Pole induction motor
($n = 2850 \text{ min}^{-1}$)
- Insulation Class F
- Protection IP 44

MATERIALS

- Pump body Stainless Steel
- Motor support Stainless Steel
- Impeller Stainless Steel
- Diffusers Stainless Steel
- Shaft with rotor Stainless Steel
- Mechanical seal Silicon Carbon

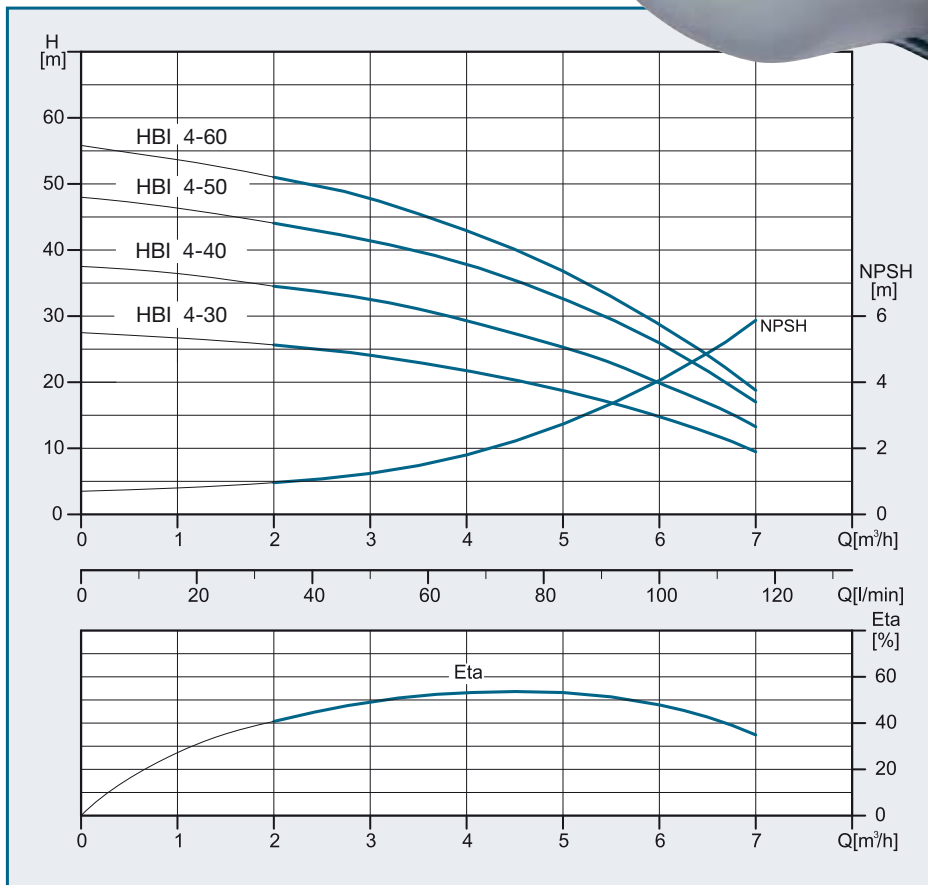

Stainless steel Aisi 304

TIPO - TYPE	DNA	DNM
HBI 4-30	1" 1/4	1"
HBI 4-40	1" 1/4	1"
HBI 4-50	1" 1/4	1"
HBI 4-60	1" 1/4	1"

TIPO - TYPE	HP	Monofase - Single-phase 1 x 230 V		Trifase - Three-phase 3 x 230/400 V	
		P ₁ [W]	I _{1/1} [A]	P ₁ [W]	I _{1/1} [A]
HBI 4-30	0,5	760	3,5	720	2,4 / 1,4
HBI 4-40	0,75	1000	4,8	980	3,2 / 1,8
HBI 4-50	1	1220	5,7	1210	4,0 / 2,3
HBI 4-60	1,5	1410	6,4	1410	4,8 / 2,7

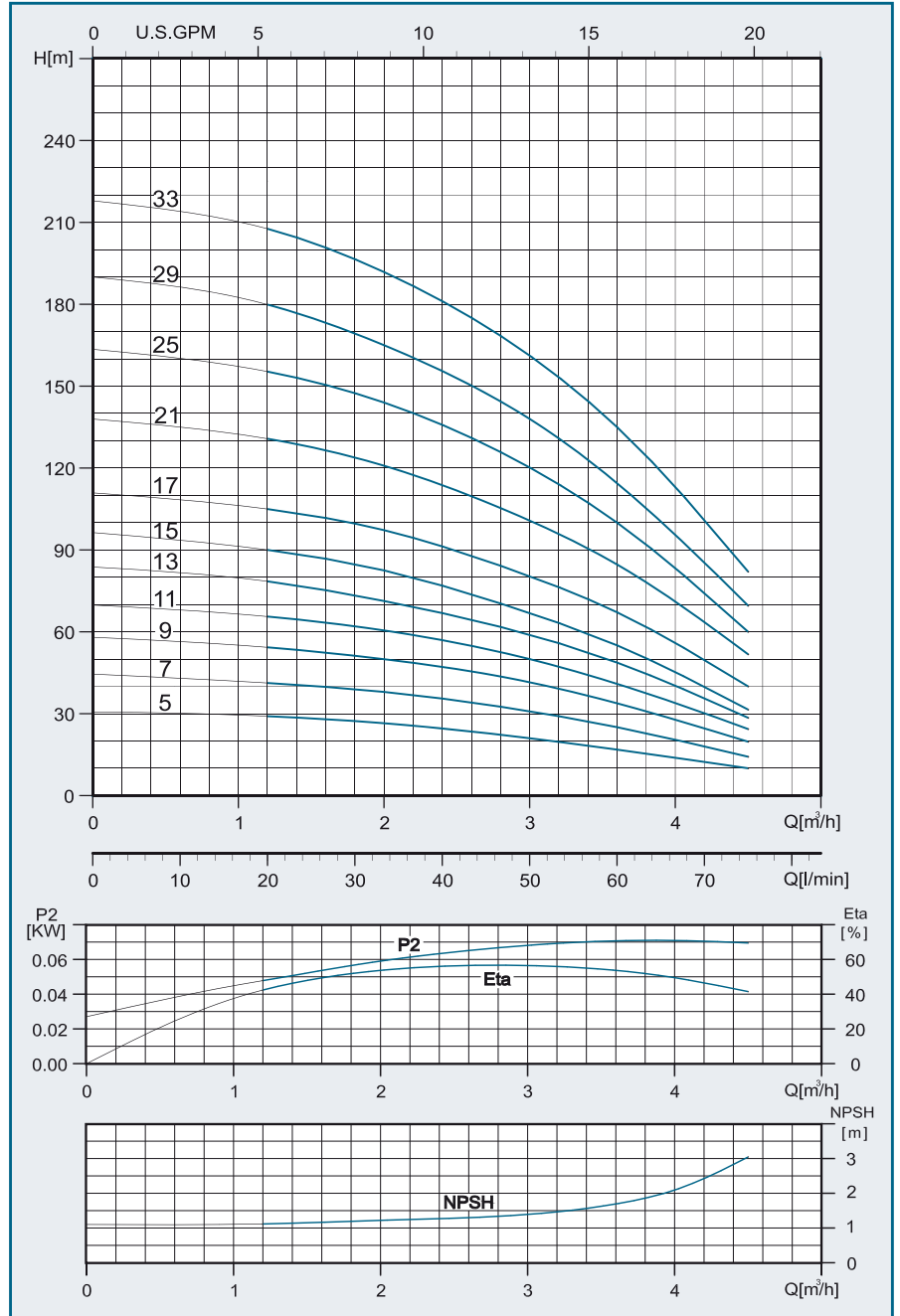

TIPO - TYPE	Potenza nominale Nominal power		Q = PORTATA - CAPACITY													
			m ³ /h	0	0,9	1,2	1,5	1,8	2,1	2,4	3	3,6	4,2			
Trifase Three-phase	HP	kW	lt/1'	0	15	20	25	30	35	40	50	60	70			
Prevalenza manometrica totale in m.C.A. - Total head in meters w.c.																
SBI 3 - 5	0,5	0,37	H (m)	30,6		29,1	28,3	27,3	26,1	24,6	21	16,8	12,3			
SBI 3 - 7	0,75	0,55		44,5		41,	40,2	39	37,4	35,5	30,9	25,1	18			
SBI 3 - 9	1	0,75		58		54,3	52,9	51,2	49,3	47,1	41,5	33,8	24,6			
SBI 3 - 11	1,5	1,1		69,8		65,6	64	62	59,7	56,9	50	40,9	30,2			
SBI 3 - 13	1,5	1,1		83,7		78,5	76,1	73,3	70,2	66,8	58,9	48,7	35,6			
SBI 3 - 15	1,5	1,1		96,3		90	87,7	84,8	81,2	76,9	66,9	55	39,9			
SBI 3 - 17	2	1,5		110,9		105	102,6	99,6	95,9	91,3	80,4	67,1	49,7			
SBI 3 - 21	3	2,2		137,9		130,7	127,6	123,8	119,2	113,7	100,7	84,6	63,5			
SBI 3 - 25	3	2,2		163,5		155,3	151,8	147,4	142,1	135,8	102,2	100	74,2			
SBI 3 - 29	3	2,2		180		179,9	175	169,3	162,7	155,5	138	114,4	85,3			
SBI 3 - 33	4	3		217,9		207,6	202,7	196,5	189,3	181,1	161,2	135	101			

OPERATING CONDITIONS

- Temperature of liquid from 0°C to 110°C (max)
- Ambient temperature max to 40°C
- Max. working pressure 25 bar

MOTOR

- Efficiency 1
- Electric standard motor (n = 2900 min⁻¹) IM V1 (IEC 34-7)
- Insulation Class F
- Protection IP 55

MATERIALS

- Suction casing *Stainless Steel Aisi 304*
- Delivery casing *Stainless Steel Aisi 304*
- Impeller *Stainless Steel Aisi 304*
- External jacket *Stainless Steel Aisi 304*
- Counterflanges *Stainless Steel Aisi 304*
- Upper cover *Stainless Steel Aisi 304*
- Lower cover *Stainless Steel Aisi 304*
- Pump shaft *Stainless Steel Aisi 303*
- Mechanical seal *Silicon/Graphite*

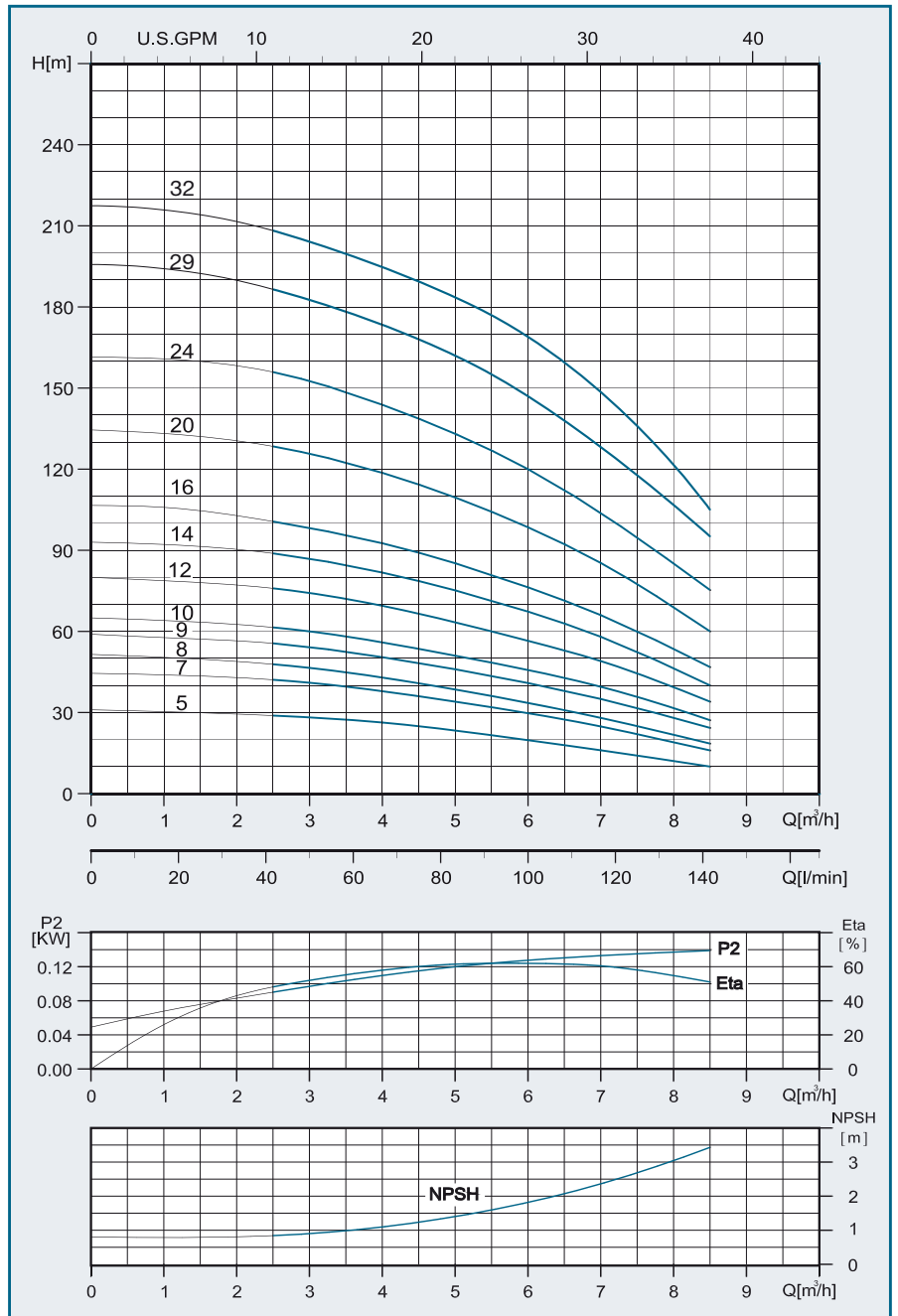

TIPO - TYPE	Potenza nominale Nominal power		Q = PORTATA - CAPACITY										
			m³/h	0	1,2	2,4	3	3,6	4,2	6	7,2	7,8	8,4
Trifase Three-phase	HP	kW	lt/1'	0	20	40	50	60	70	100	120	130	140
Prevalenza manometrica totale in m.C.A. - Total head in meters w.c.													
SBI 5 - 5	1	0,75	H (m)	31		29	28,2	27,2	25,8	19,8	15,2	12,9	10,4
SBI 5 - 7	1,5	1,1		44,5		42,3	41	39,3	37,2	29,8	23,7	20,2	16,6
SBI 5 - 8	1,5	1,1		51,5		48,1	46,5	44,5	42,1	33,5	26,8	23	19,2
SBI 5 - 9	2	1,5		59		55,8	54,2	52,1	49,6	40,9	33,7	29,5	25,1
SBI 5 - 10	2	1,5		65		61,7	60	57,7	55	45,7	38,1	33,3	28
SBI 5 - 12	3	2,2		80		76,2	74,2	71,5	68,3	56,5	47,2	41,1	35,1
SBI 5 - 14	3	2,2		93		89,2	86,9	84	80,5	67,3	55,8	48,8	41,3
SBI 5 - 16	3	2,2		106,6		101,1	98,2	95	91,2	76,3	63,7	56,2	48,1
SBI 5 - 20	4	3		134,5		128,9	125,7	121,7	117	98,5	82,3	72,4	61,8
SBI 5 - 24	5,5	4		161,5		156,4	152,6	147,6	141,8	120	100,2	88,9	77,2
SBI 5 - 29	5,5	4		196,3		189,3	185	180	173,4	147,7	123,5	110,3	96,9
SBI 5 - 32	7,5	5,5		217		210	205,3	199,2	191,6	160,9	135,7	121,4	106,4

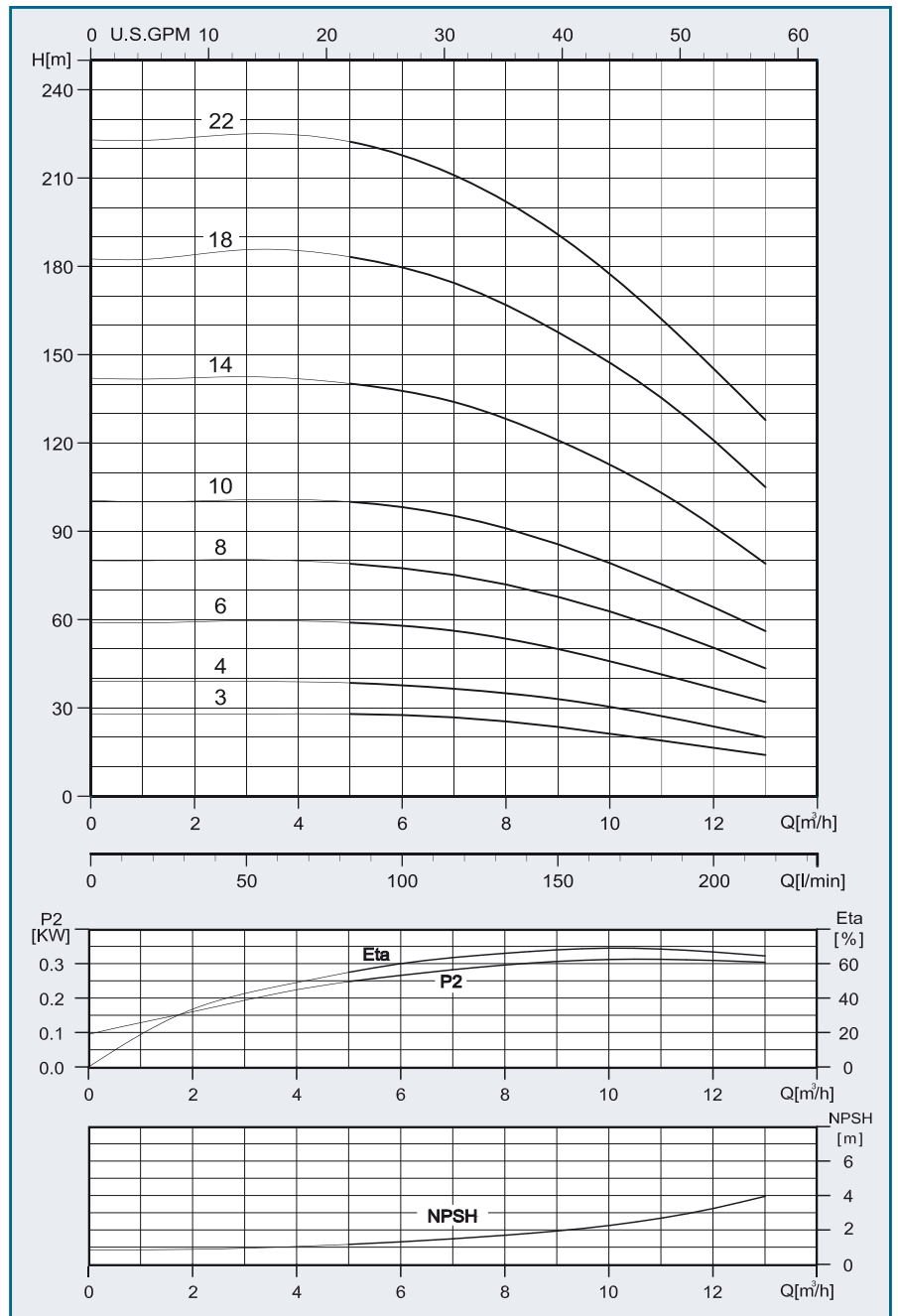

TIPO - TYPE	Potenza nominale Nominal power		Q = PORTATA - CAPACITY																			
			m³/h	0	1,2	2,4	3,6	6	7,2	7,8	9	10,8	12									
Trifase Three-phase	HP	kW	lt/1'	0	20	40	60	100	120	130	150	180	200									
			Prevalenza manometrica totale in m.C.A. - Total head in meters w.c.																			
SBI 10 - 3	1,5	1,1	H (m)	28					27,6	26,5	25,4	23,5	19,4	16,4								
SBI 10 - 4	2	1,5		39					37,7	36,2	35	33	27,9	23,7								
SBI 10 - 6	3	2,2		59					57,9	55,7	53,6	50	42,3	36,7								
SBI 10 - 8	4	3		80					77,5	74,6	72	67,7	58,2	50,4								
SBI 10 - 10	5,5	4		100,5					98,2	94,5	91,1	85,6	73,5	64,2								
SBI 10 - 14	7,5	5,5		142					137,7	132,9	128,3	120,9	105,11	91,6								
SBI 10 - 18	10	7,5		182,5					179,7	173,1	167,1	157,6	137,8	120,9								
SBI 10 - 22	10	7,5		223					217,8	209,3	202,2	190,8	165,2	145,3								

OPERATING CONDITIONS

- Temperature of liquid from 0°C to 110°C (max)
- Ambient temperature max to 40°C
- Max. working pressure 25 bar

MOTOR

- Efficiency 1
- Electric standard motor (n = 2900 min⁻¹) IM V1 (IEC 34-7)
- Insulation Class F
- Protection IP 55

MATERIALS

- Suction casing *Stainless Steel Aisi 304*
- Delivery casing *Stainless Steel Aisi 304*
- Impeller *Stainless Steel Aisi 304*
- External jacket *Stainless Steel Aisi 304*
- Counterflanges *Stainless Steel Aisi 304*
- Upper cover *Stainless Steel Aisi 304*
- Lower cover *Stainless Steel Aisi 304*
- Pump shaft *Stainless Steel Aisi 303*
- Mechanical seal *Silicon/Graphite*

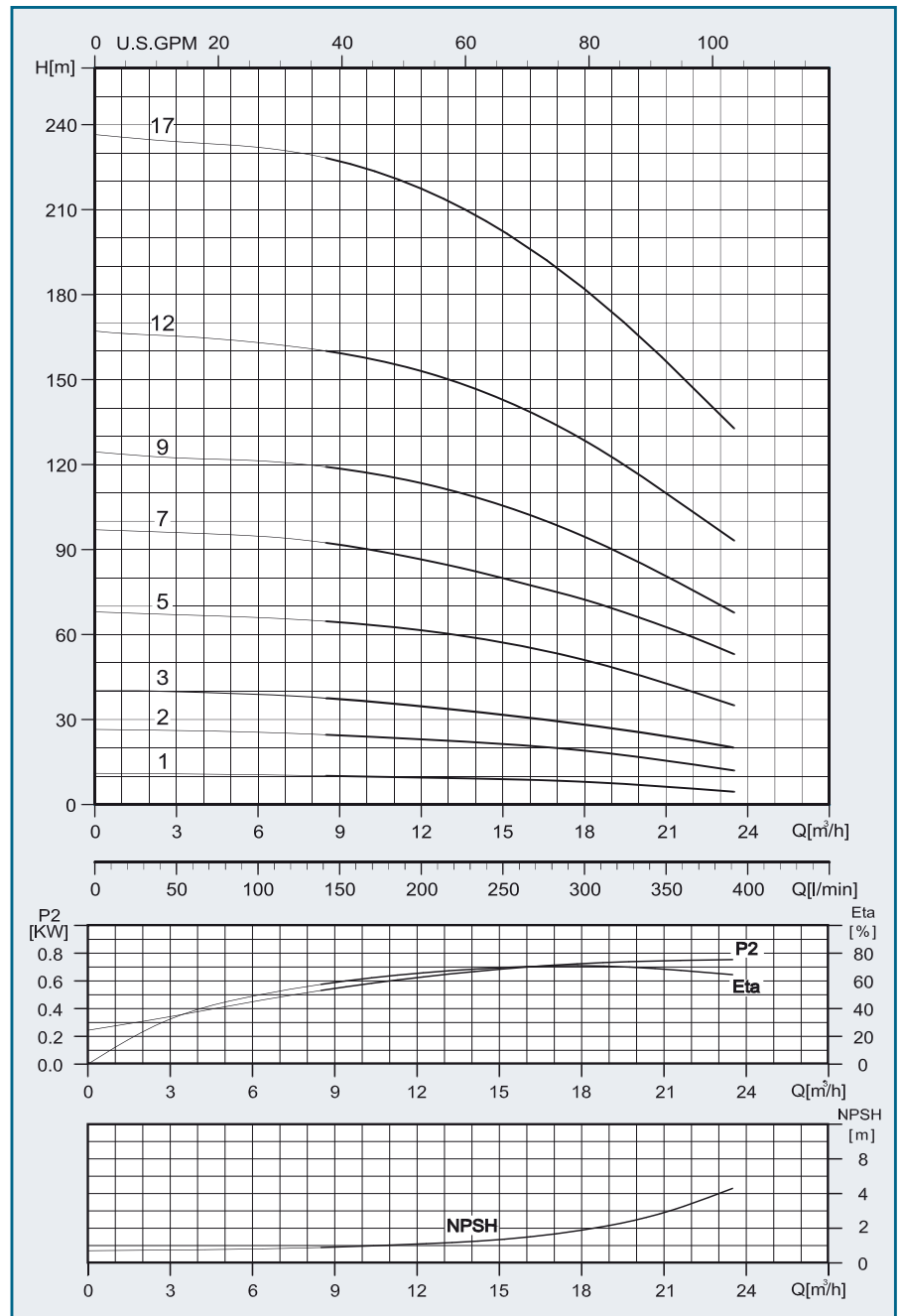

TIPO - TYPE	Potenza nominale Nominal power		Q = PORTATA - CAPACITY										
			m³/h	0	3	6	9	10,8	12	14,4	16,2	18	21
Trifase Three-phase	HP	kW	lt/l'	0	50	100	150	180	100	240	270	300	350
Prevalenza manometrica totale in m.C.A. - Total head in meters w.c.													
SBI 15 - 1	1,5	1,1	H (m)	11			10	9,7	9,5	9,2	8,7	8	6,3
SBI 15 - 2	3	2,2		26,5			24,4	23,6	23	22	20,7	19	15,5
SBI 15 - 3	4	3		40,5			37,4	36	35	33,3	31,4	29	24,4
SBI 15 - 5	5,5	4		68			64,3	62,8	61,5	58,8	55,4	51	42,8
SBI 15 - 7	7,5	5,5		97			92,4	90	88	84,2	80	74	63,7
SBI 15 - 9	10	7,5		124,5			118,6	115,8	113,4	108,5	102,2	94,5	80,6
SBI 15 - 12	15	11		167,2			159,3	155,9	153	146,7	138,6	128,5	109,9
SBI 15 - 17	20	15		236,5			227,1	221,9	217,4	208	196,2	182	156,5

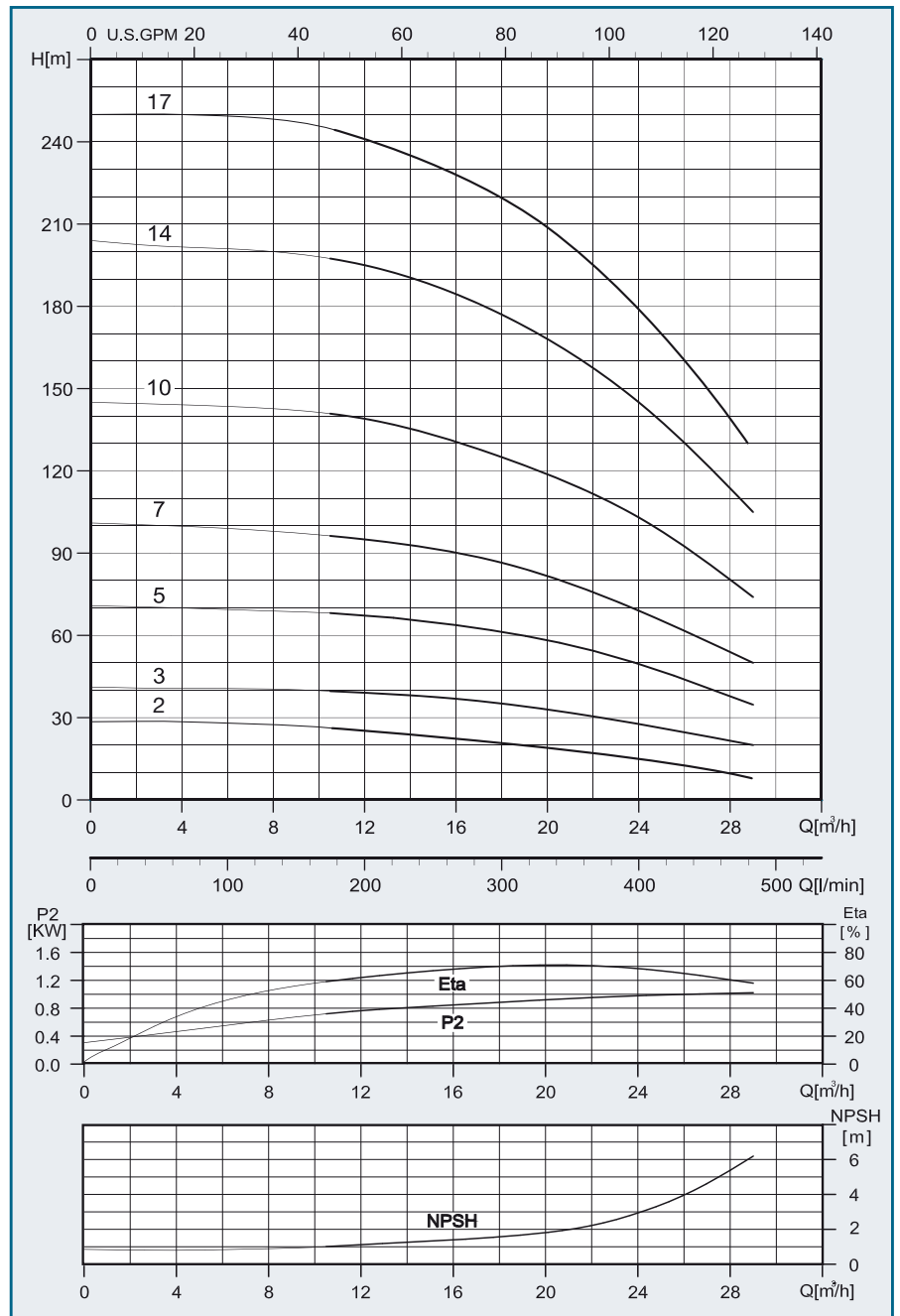

TIPO - TYPE	Potenza nominale Nominal power		Q = PORTATA - CAPACITY										
			m³/h	0	6	9	12	14,4	16,2	18	21	24	27
Trifase Three-phase	HP	kW	lt/1'	0	100	150	200	240	270	300	350	400	450
Prevalenza manometrica totale in m.C.A. - Total head in meters w.c.													
SBI 20 - 2	3	2,2	H (m)	27,5			25,3	24,4	23,3	22,2	20,2	17,2	13,4
SBI 20 - 3	5,5	4		41,2			39,1	38,1	36,9	35,1	31,8	27,7	23,1
SBI 20 - 5	7,5	5,5		70,8			67,3	65,8	63,7	61,3	56,4	49,6	41
SBI 20 - 7	10	7,5		101			95	92,9	90,2	86,5	78,8	69	57,8
SBI 20 - 10	15	11		145			139	135,4	130,6	125	115,3	103	86,5
SBI 20 - 14	20	15		204			195	190,5	184,5	177	163	145	122,1
SBI 20 - 17	25	18,5		250			238,7	233,3	226,4	217,8	201,2	179	150,8

OPERATING CONDITIONS

- Temperature of liquid from 0°C to 110°C (max)
- Ambient temperature max to 40°C
- Max. working pressure 25 bar

MOTOR

- Efficiency 1
- Electric standard motor ($n = 2900 \text{ min}^{-1}$) IM V1 (IEC 34-7)
- Insulation Class F
- Protection IP 55

MATERIALS

- Suction casing *Stainless Steel Aisi 304*
- Delivery casing *Stainless Steel Aisi 304*
- Impeller *Stainless Steel Aisi 304*
- External jacket *Stainless Steel Aisi 304*
- Counterflanges *Stainless Steel Aisi 304*
- Upper cover *Stainless Steel Aisi 304*
- Lower cover *Stainless Steel Aisi 304*
- Pump shaft *Stainless Steel Aisi 303*
- Mechanical seal *Silicon/Graphite*

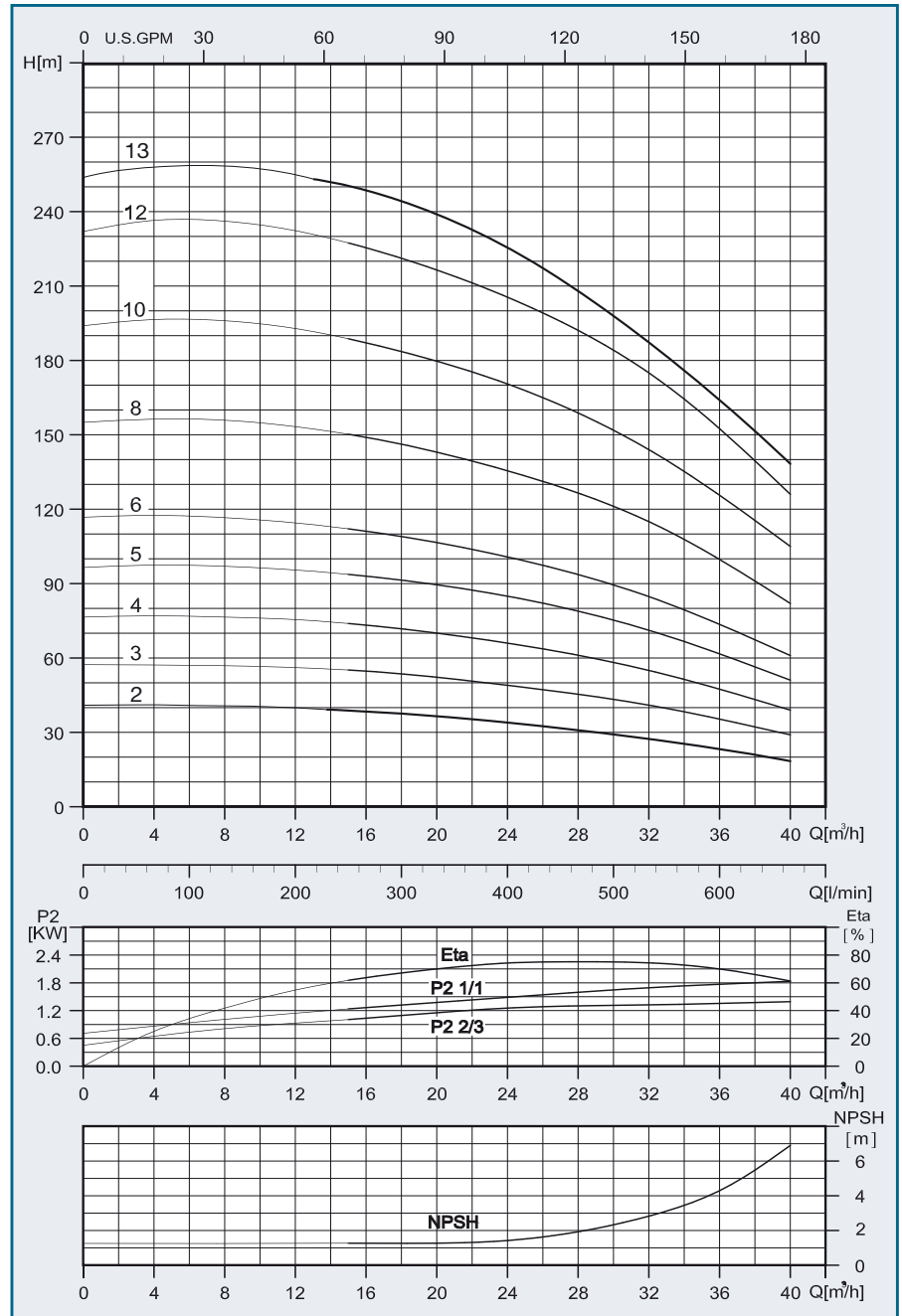

TIPO - TYPE	Potenza nominale Nominal power		Q = PORTATA - CAPACITY										
			m³/h	0	10,8	16,2	18	21	24	27	30	33	36
Trifase Three-phase	HP	kW	lt/1'	0	180	270	300	350	400	450	500	550	600
Prevalenza manometrica totale in m.C.A. - Total head in meters w.c.													
SBI 32 - 2	5,5	4	H (m)	39,1		36,2	35,5	34,3	32,8	31	28,8	26,2	23
SBI 32 - 3	7,5	5,5		57,3		54,7	53,6	51,5	49	46,4	43,3	39,7	35,4
SBI 32 - 4	10	7,5		76,5		73,3	71,7	69,1	66	62,4	58,2	53,2	47,4
SBI 32 - 5	15	11		96,5		93	91,4	88,5	84,9	80,5	75,3	69	61,7
SBI 32 - 6	15	11		116,7		111,1	109	105,2	100,8	95,6	89,5	82,2	73,6
SBI 32 - 8	20	15		155		149	146,2	141,2	135,5	108,9	121,2	111,5	99,8
SBI 32 - 10	25	18,5		194		187,1	183,6	177,6	170,5	162	151,8	139,7	125,7
SBI 32 - 12	30	22		232		225,4	221,2	213,9	205,5	195,7	184,1	169,9	152,5
SBI 32 - 13	40	30		254		247,3	242,9	235,2	226	215,2	202,4	187,1	169

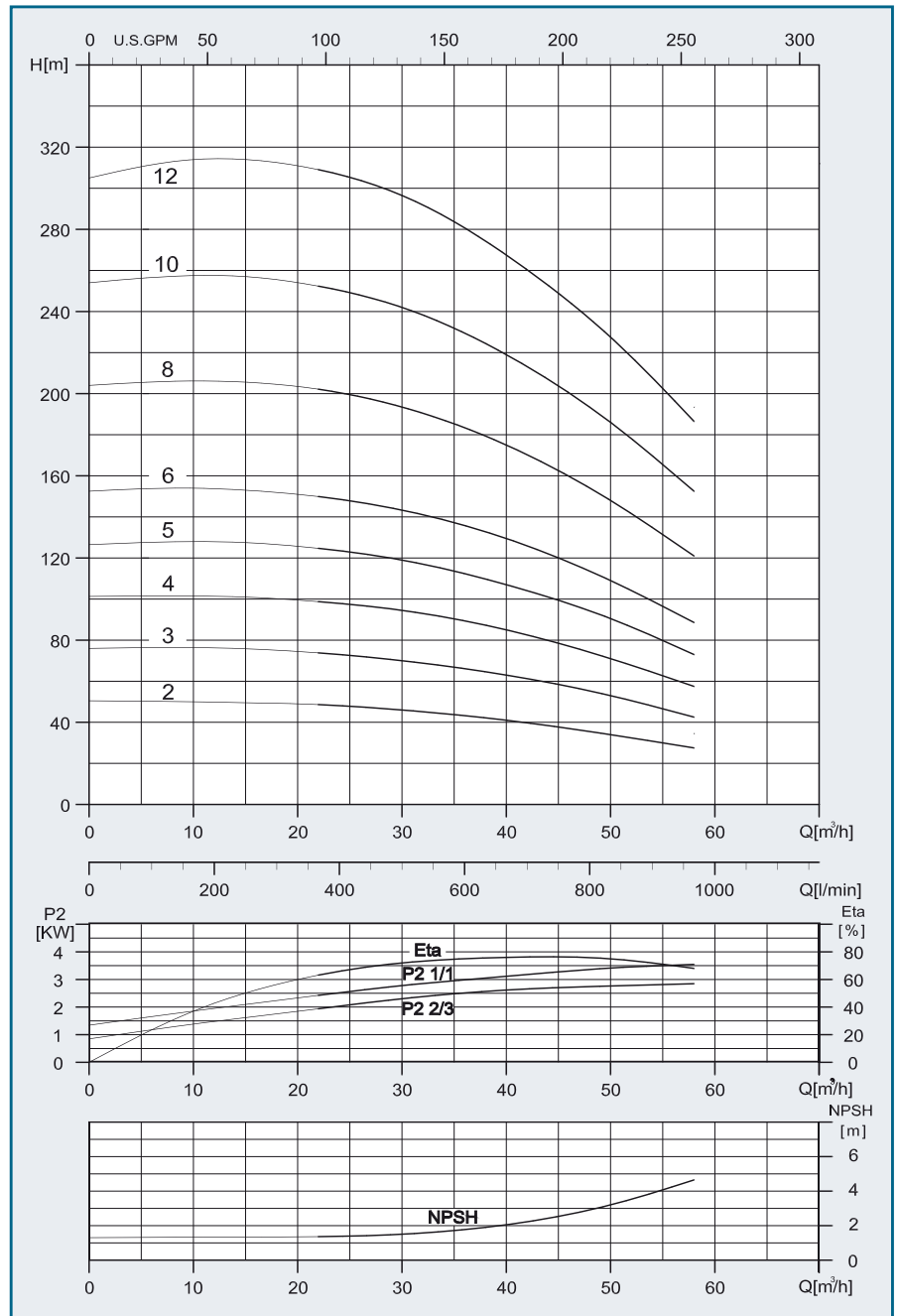

TIPO - TYPE	Potenza nominale Nominal power		Q = PORTATA - CAPACITY																		
			m³/h	0	6	9	12	24	30	36	42	48	54								
Trifase Three-phase	HP	kW	lt/1'	0	100	150	200	400	500	600	700	800	900								
			Prevalenza manometrica totale in m.C.A. - Total head in meters w.c.																		
SBI 45 - 2	10	7,5	H (m)	50,5				48,1	46	43,2	39,8	35,5	30,8								
SBI 45 - 3	15	11		76				73	70	66,1	61,3	55,3	47,9								
SBI 45 - 4	20	15		101,3				97,9	94,5	89,4	82,5	74,1	64,4								
SBI 45 - 5	25	18,5		126,5				123,6	119	112,4	104,1	94,3	82,1								
SBI 45 - 6	30	22		152,5				148,6	143,3	135,8	125,9	113,6	99,1								
SBI 45 - 8	40	30		204				200,5	193,5	183,4	170,3	154,1	134,9								
SBI 45 - 10	50	37		254				250,3	242	229,5	213,2	193,5	169,8								
SBI 45 - 12	60	45		305				306,7	296,5	280,7	260,4	236,5	207,8								

OPERATING CONDITIONS

- Temperature of liquid from 0°C to 110°C (max)
- Ambient temperature max to 40°C
- Max. working pressure 25 bar

MOTOR

- Efficiency 1
- Electric standard motor (n = 2900 min⁻¹) IM V1 (IEC 34-7)
- Insulation Class F
- Protection IP 55

MATERIALS

- Suction casing *Stainless Steel Aisi 304*
- Delivery casing *Stainless Steel Aisi 304*
- Impeller *Stainless Steel Aisi 304*
- External jacket *Stainless Steel Aisi 304*
- Counterflanges *Stainless Steel Aisi 304*
- Upper cover *Stainless Steel Aisi 304*
- Lower cover *Stainless Steel Aisi 304*
- Pump shaft *Stainless Steel Aisi 303*
- Mechanical seal *Silicon/Graphite*

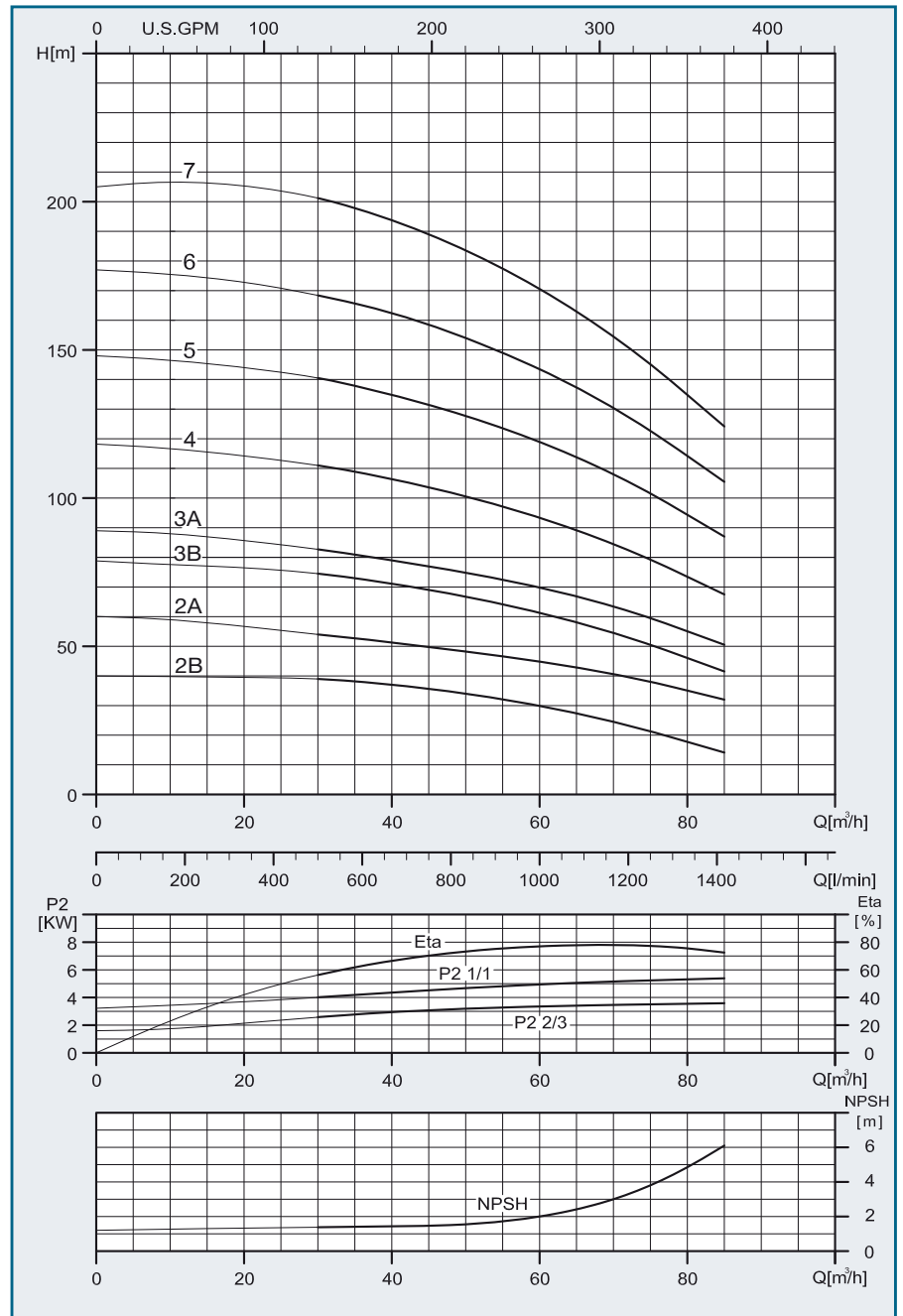

TIPO - TYPE	Potenza nominale Nominal power		Q = PORTATA - CAPACITY										
			m³/h	0	24	30	36	42	48	54	66	78	84
Trifase Three-phase	HP	kW	lt/1'	0	400	500	600	700	800	900	1100	1300	1400
Prevalenza manometrica totale in m.C.A. - Total head in meters w.c.													
SBI 64 - 2B	10	7,5	H (m)	40			38	36,5	34,7	32,5	26,8	19,2	14,9
SBI 64 - 2A	15	11		60,1			52,4	50,7	48,8	46,9	42,5	36,3	32,6
SBI 64 - 3B	20	15		78,8			72,6	70,4	67,7	64,7	57,4	47,8	42,4
SBI 64 - 3A	25	18,5		89			80,6	78,2	75,7	72,9	66,2	56,8	51,4
SBI 64 - 4	30	22		118,2			108,5	105,4	101,8	97,8	88,3	75,8	68,7
SBI 64 - 5	40	30		148			137,3	133,5	129,2	124,4	112,7	97,3	88,5
SBI 64 - 6	50	37		177			165	160,9	155,9	150	136	117,7	107,3
SBI 64 - 7	60	45		205			197,1	192	185,8	178,7	161,4	139	126,3

POMPE SOMMERSE MULTISTADIO PER POZZI 4" MULTISTAGE SUBMERSIBLE PUMPS FOR 4" WELLS

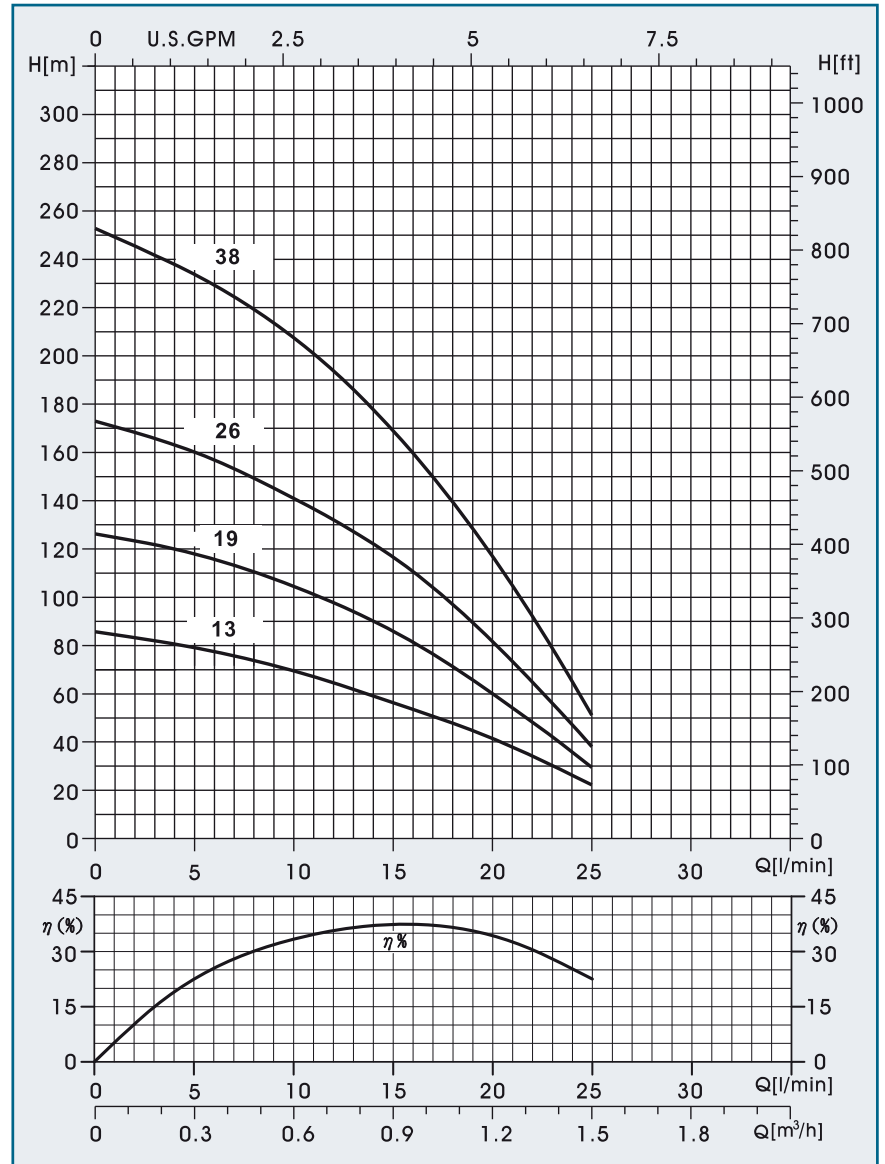

TIPO TYPE	Stadi - Stages	Potenza Power KW HP		Q = PORTATA - CAPACITY															Dimensioni Dimensions	
				l/min 0	5	10	15	20	25	30	35	40	45	50	60	70	80	Length (mm)	Weight (kg)	
				m³/h 0	0.3	0.6	0.9	1.2	1.5	1.8	2.1	2.4	2.7	3.0	3.6	4.2	4.8	H = Prevalenza manometrica totale in m.C.A. - Total head in meters w.c.		
ST5-13	13	0.37	0.5	86	78	70	56	42	23									377	3.7	
ST5-19	19	0.55	0.75	126	118	105	86	60	30									481	4.7	
ST5-26	26	0.75	1.0	173	160	141	117	81	39									642	5.8	
ST5-38	38	1.1	1.5	253	234	208	169	117	52									864	8.2	

POMPE SOMMERSE MULTISTADIO PER POZZI 4" MULTISTAGE SUBMERSIBLE PUMPS FOR 4" WELLS

APPLICATION

Multistage submersible water pumps for 4" deep wells (DN 100 mm). Particularly suitable for civil and industrial purposes, for sprinkler and food irrigation plants, in fire installations and generally speaking for clean water supplying.

PUMP MATERIALS

The discharge has a built-in check valve in stainless steel. The pump body is covered by a 304 polished stainless steel shell. The shafts are made from hex 304 stainless steel bar material. Shafts for pumps with 19 and fewer stages are supplied with one shaft bearing. Shafts for pumps with more than 19 stages are supplied with two shaft bearings. Impellers are made of Diffusers are made of polycarbonate. Built-in 304 stainless steel strainer. Couplings are made from sintered 304 stainless steel material, with NEMA specifications.

OPERATING CONDITIONS

- Liquid temperature up to 35°C
- Sand content max. 60 g/m³
- Start/hour 20 max.

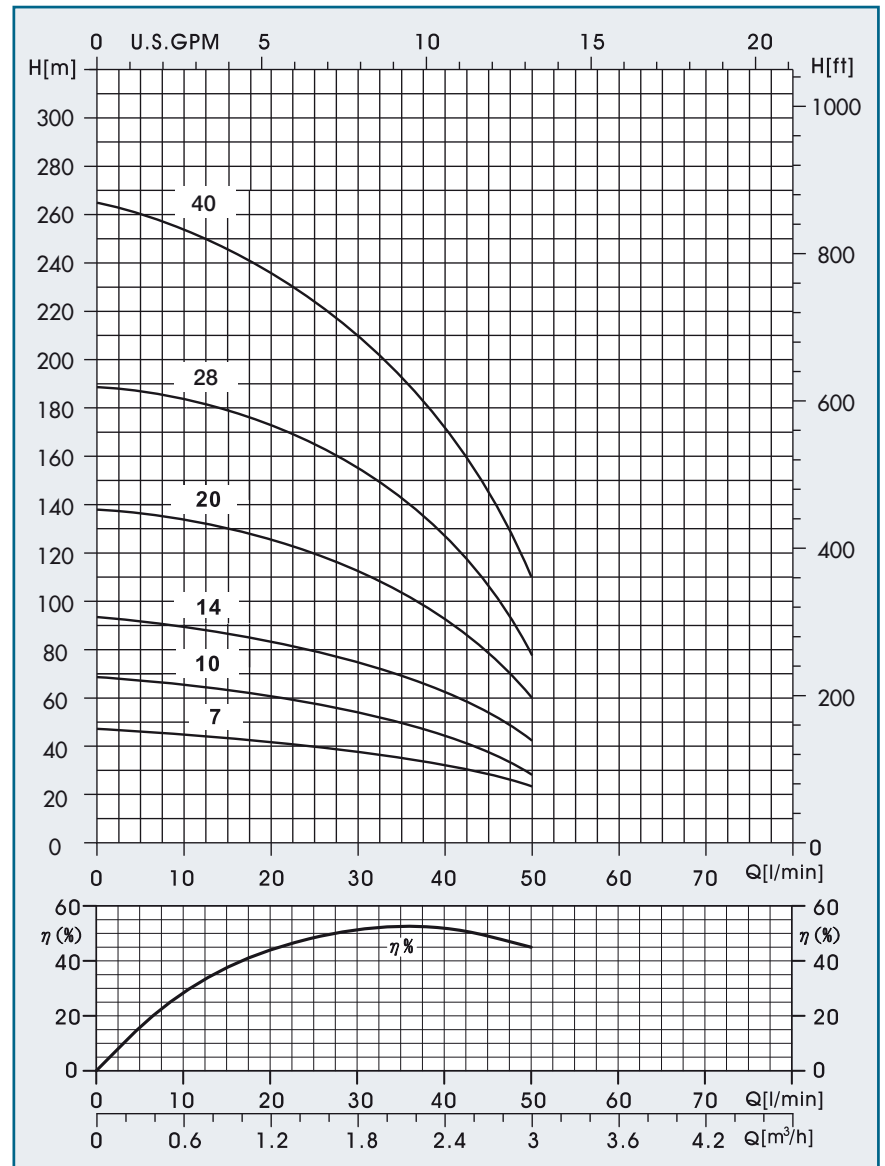

TIPO TYPE	Stadi - Stages	Potenza Power		Q = PORTATA - CAPACITY														Dimensioni Dimensions	
				l/min 0	5	10	15	20	25	30	35	40	45	50	60	70	80		
		KW	HP	m³/h 0	0.3	0.6	0.9	1.2	1.5	1.8	2.1	2.4	2.7	3.0	3.6	4.2	4.8	(mm)	(kg)
ST10-07	7	0,37	0,5	46			43	42	39	36	33	29	26	22				271	2,8
ST10-10	10	0,55	0,75	69			65	63	60	55	50	44	37	29				324	3,3
ST10-14	14	0,75	1	92			86	83	79	74	67	60	52	42				394	3,9
ST10-20	20	1,1	1,5	139			131	127	120	111	101	90	75	60				499	4,9
ST10-28	28	1,5	2	189			180	172	164	156	138	117	98	78				680	6,5
ST10-40	40	2,2	3	265			251	234	220	210	183	153	130	110				885	8,9

H = Prevalenza monometrica totale in m.C.A. - Total head in meters w.c.

POMPE SOMMERSE MULTISTADIO PER POZZI 4"
MULTISTAGE SUBMERSIBLE PUMPS FOR 4" WELLS

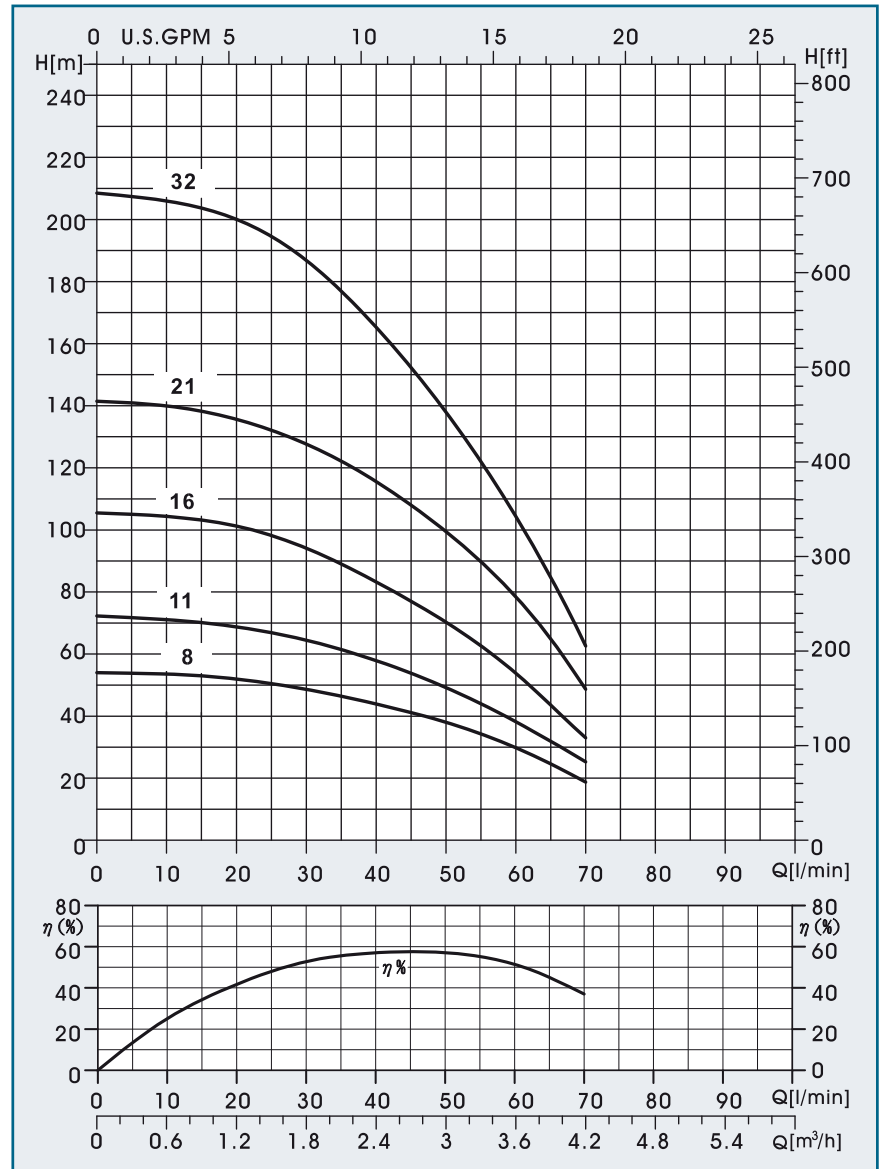

TIPO TYPE	Stadi - Stages	Potenza Power KW HP		Q = PORTATA - CAPACITY														Dimensioni Dimensions Length (mm) Weight (kg)	
				l/min 0	5	10	15	20	25	30	35	40	45	50	60	70	80		
				m ³ /h 0	0.3	0.6	0.9	1.2	1.5	1.8	2.1	2.4	2.7	3.0	3.6	4.2	4.8		
H = Prevalenza manometrica totale in m.C.A. - Total head in meters w.c.																			
ST13-08	8	0.55	0.75	54				51	50	49	46	43	41	38	30	19		289	2.9
ST13-11	11	0.75	1.0	72				68	66	64	61	58	54	49	38	26		342	3.4
ST13-16	16	1.1	1.5	106				101	98	95	89	83	77	70	54	33		430	4.2
ST13-21	21	1.5	2.0	142				135	132	127	122	115	108	100	79	49		519	5.0
ST13-32	32	2.2	3.0	208				200	194	187	177	165	152	138	104	62		749	7.1

POMPE SOMMERSE MULTISTADIO PER POZZI 4" MULTISTAGE SUBMERSIBLE PUMPS FOR 4" WELLS

APPLICATION

Multistage submersible water pumps for 4" deep wells (DN 100 mm). Particularly suitable for civil and industrial purposes, for sprinkler and food irrigation plants, in fire installations and generally speaking for clean water supplying.

PUMP MATERIALS

The discharge has a built-in check valve in stainless steel. The pump body is covered by a 304 polished stainless steel shell. The shafts are made from hex 304 stainless steel bar material. Shafts for pumps with 19 and fewer stages are supplied with one shaft bearing. Shafts for pumps with more than 19 stages are supplied with two shaft bearings. Impellers are made of Diffusers are made of polycarbonate. Built-in 304 stainless steel strainer. Couplings are made from sintered 304 stainless steel material, with NEMA specifications.

OPERATING CONDITIONS

- Liquid temperature up to 35°C
- Sand content max. 60 g/m³
- Start/hour 20 max.

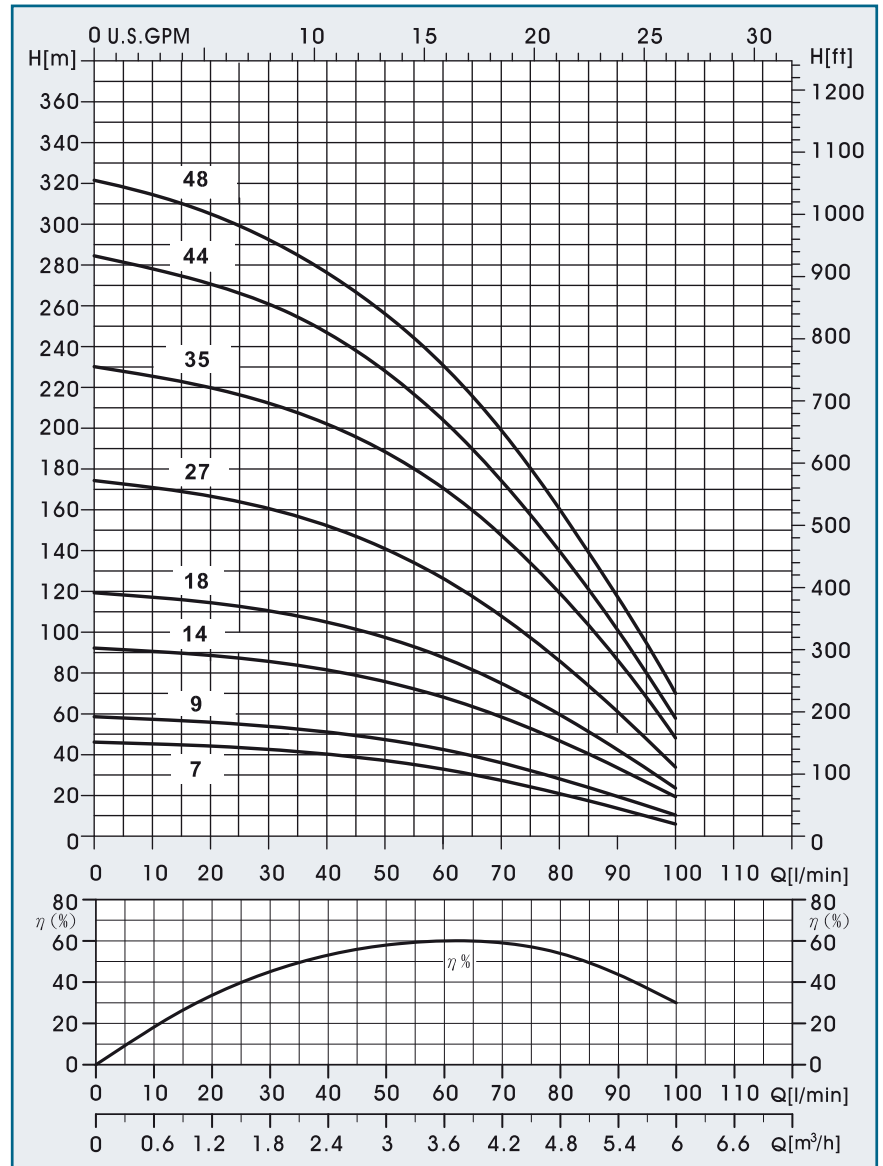

TIPO TYPE	Stadi - Stages	Potenza Power		Q = PORTATA - CAPACITY														Dimensioni Dimensions		
				l/min 0	15	20	25	30	35	40	45	50	60	70	80	90	100			120
				m³/h 0	0.9	1.2	1.5	1.8	2.1	2.4	2.7	3.0	3.6	4.2	4.8	5.4	6.0	7.2	Length (mm)	Weight (kg)
ST18-07	7	0.55	0.75	46			43	42	41	40	39	37	33	28	21	13	7		301	3.0
ST18-09	9	0.75	1.0	59			55	54	52	51	49	47	43	37	28	20	10		344	3.3
ST18-14	14	1.1	1.5	93			87	86	83	81	79	76	68	58	47	33	20		452	4.1
ST18-18	18	1.5	2.0	120			113	111	108	105	102	98	88	75	60	42	25		538	4.7
ST18-27	27	2.2	3.0	175			164	161	157	152	147	141	127	109	87	61	35		767	6.2
ST18-35	35	3.0	4.0	231			217	212	208	202	196	189	170	149	120	87	50		934	7.9
ST18-44	44	3.7	5.0	285			266	260	254	248	238	229	203	172	139	100	59		1128	9.3
ST18-48	48	4.0	5.5	322			299	292	285	276	267	256	231	199	160	118	70		1253	9.9

POMPE SOMMERSE MULTISTADIO PER POZZI 4" MULTISTAGE SUBMERSIBLE PUMPS FOR 4" WELLS

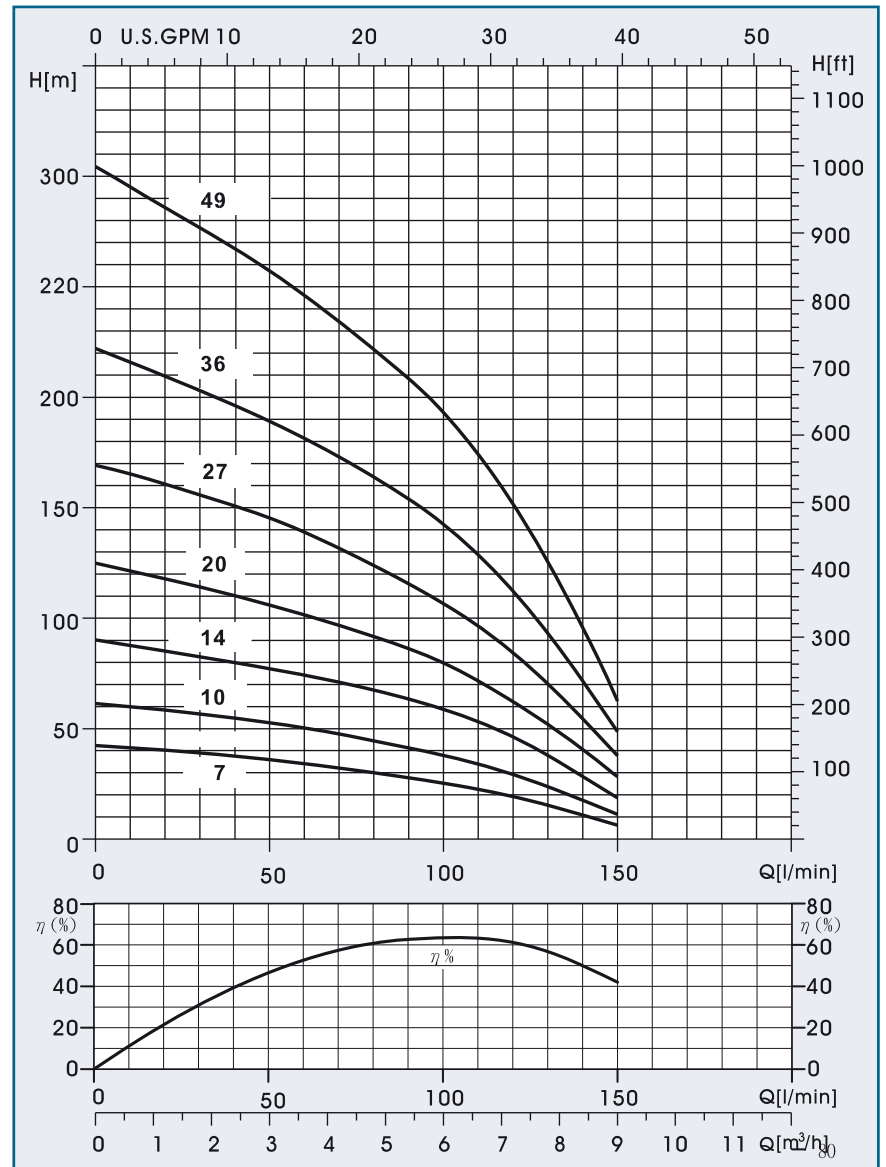

TIPO TYPE	Stadi - Stages	Potenza Power		Q = PORTATA - CAPACITY																Dimensioni Dimensions		
				l/min	0	30	35	40	45	50	60	70	80	90	100	120	140	160	180			200
		KW	HP	m ³ /h	0	1.8	2.1	2.4	2.7	3.0	3.6	4.2	4.8	5.4	6.0	7.2	8.4	9.6	10.8	12	13	Length (mm)
ST35-07	7	0.75	1.0	42					36	34	32	30	28	25	19	11					390	3.7
ST35-10	10	1.1	1.5	62					53	51	48	45	41	38	29	18					483	4.6
ST35-14	14	1.5	2.0	90					77	74	71	68	63	59	46	28					607	5.7
ST35-20	20	2.2	3.0	125					107	102	97	92	86	80	62	40					831	7.5
ST35-27	27	3.0	4.0	169					145	139	131	123	115	107	84	55					1048	9.6
ST35-36	36	4.0	5.5	221					190	181	173	164	154	143	112	72					1318	12.2
ST35-49	49	5.5	7.5	302					257	246	234	222	209	193	151	96					1802	15.9

H = Prevalenza manometrica totale in m.C.A. - Total head in meters w.c.

POMPE SOMMERSE MULTISTADIO PER POZZI 4" MULTISTAGE SUBMERSIBLE PUMPS FOR 4" WELLS

APPLICATION

Multistage submersible water pumps for 4" deep wells (DN 100 mm). Particularly suitable for civil and industrial purposes, for sprinkler and food irrigation plants, in fire installations and generally speaking for clean water supplying.

PUMP MATERIALS

The discharge has a built-in check valve in stainless steel. The pump body is covered by a 304 polished stainless steel shell. The shafts are made from hex 304 stainless steel bar material. Shafts for pumps with 19 and fewer stages are supplied with one shaft bearing. Shafts for pumps with more than 19 stages are supplied with two shaft bearings. Impellers are made of Diffusers are made of polycarbonate. Built-in 304 stainless steel strainer. Couplings are made from sintered 304 stainless steel material, with NEMA specifications.

OPERATING CONDITIONS

- Liquid temperature up to 35°C
- Sand content max. 60 g/m³
- Start/hour 20 max.

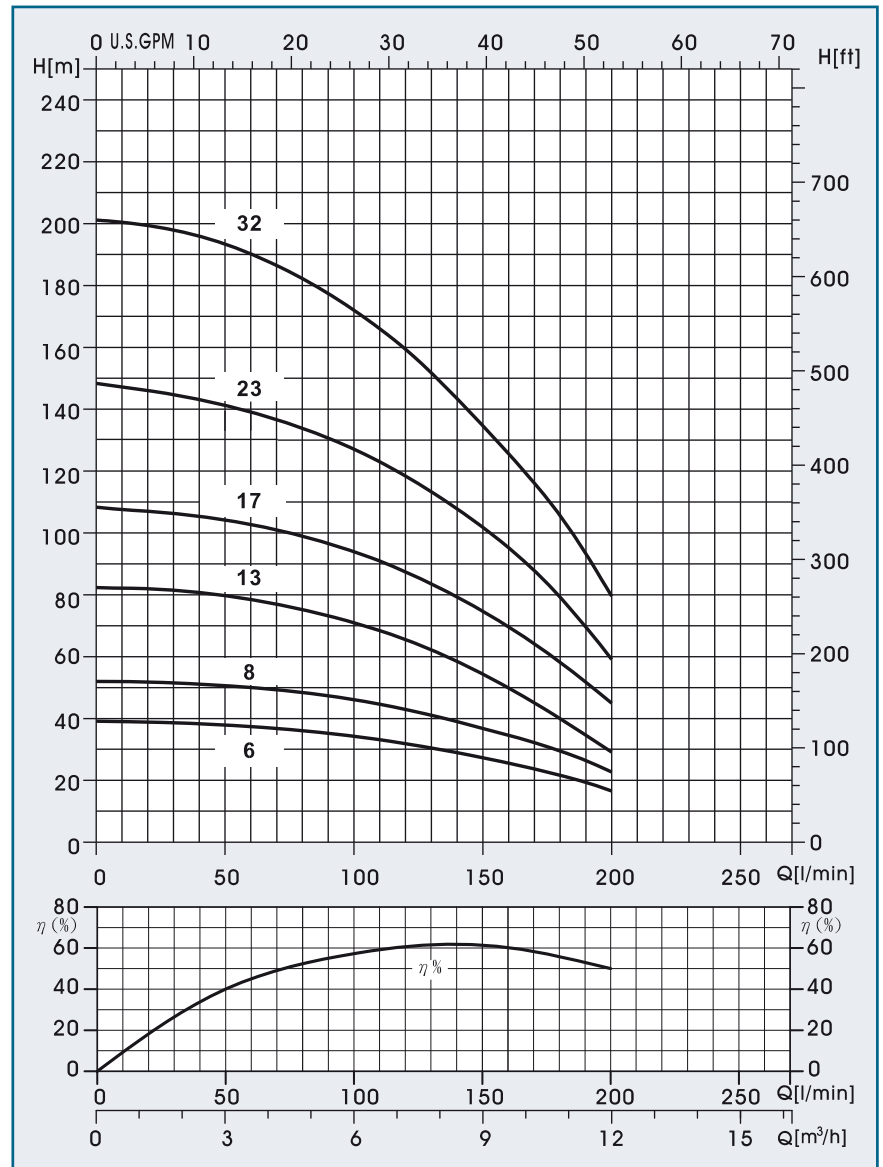

TIPO TYPE	Stadi - Stages	Potenza Power KW HP		Q = PORTATA - CAPACITY																	Dimensioni Dimensions			
				l/min 0	30	35	40	45	50	60	70	80	90	100	120	140	160	180	200	220	Length (mm)	Weight (kg)		
ST40-06	6	1.1	1.5	39										36	35	34	32	29	26	22	17		356	3.4
ST40-08	8	1.5	2.0	52										48	47	46	43	39	35	29	24		418	4.0
ST40-13	13	2.2	3.0	82										75	73	71	66	59	50	40	30		573	5.5
ST40-17	17	3.0	4.0	108										98	96	94	87	79	70	58	46		697	6.6
ST40-23	23	4.0	5.5	148										134	131	127	118	108	95	79	60		921	8.4
ST40-32	32	5.5	7.5	202										182	178	172	160	143	125	105	80		1238	11.0

POMPE SOMMERSE MULTISTADIO PER POZZI 4"
MULTISTAGE SUBMERSIBLE PUMPS FOR 4" WELLS

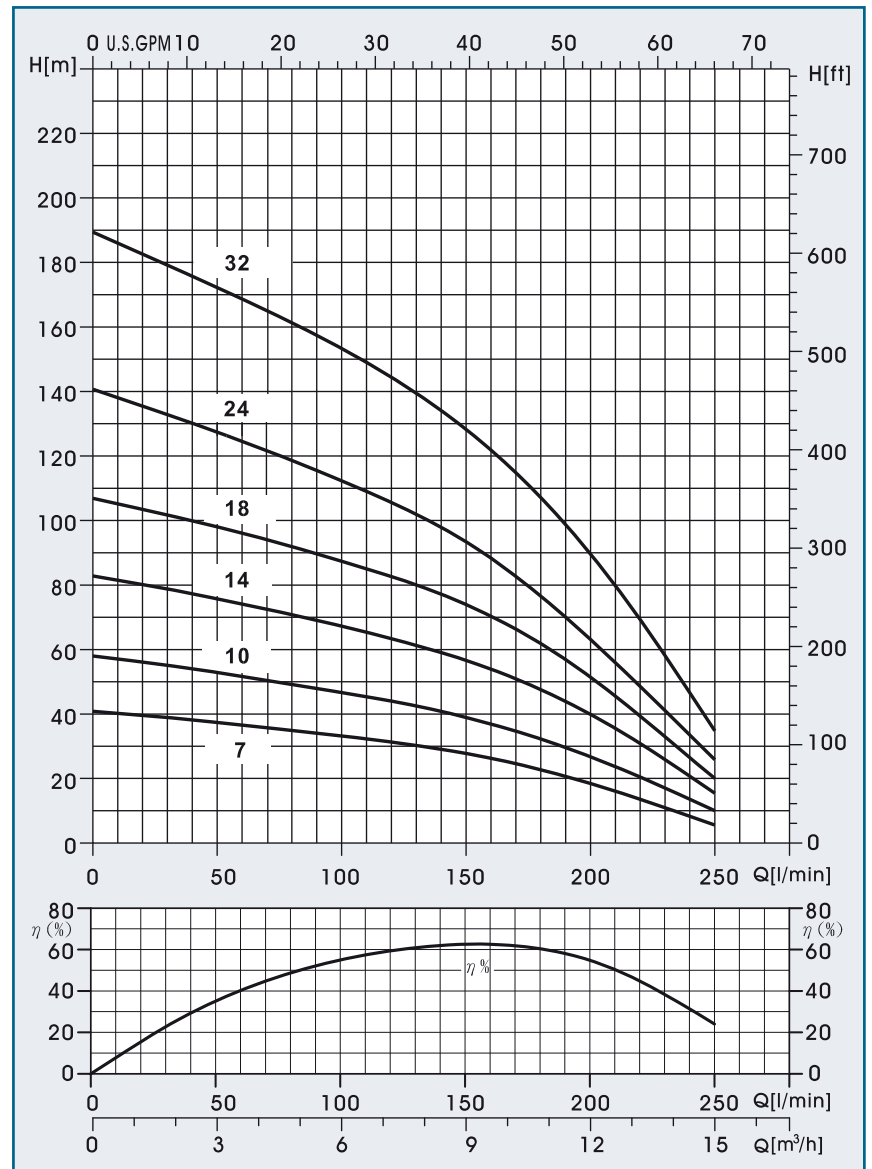

TIPO TYPE	Stadi - Stages	Potenza Power		Q = PORTATA - CAPACITY																	Dimensioni Dimensions		
				H = Prevalenza manometrica totale in m.C.A. - Total head in meters w.c.																			
		KW	HP	l/min 0	70	80	90	100	120	140	160	180	200	220	240	260	280	300	320	340	Length (mm)	Weight (kg)	
ST55-07	7	1.1	1.5	41		35	34	33	32	29	26	23	18	14	8							537	5.3
ST55-10	10	1.5	2.0	58		49	48	47	44	41	37	32	27	20	13							693	6.7
ST55-14	14	2.2	3.0	83		71	69	67	63	58	54	48	40	31	20							901	8.5
ST55-18	18	3.0	4.0	107		92	90	87	83	77	70	62	52	39	26							1147	10.4
ST55-24	24	4.0	5.5	141		118	116	113	106	97	88	77	63	49	33							1449	13.2
ST55-32	32	5.5	7.5	189		162	157	153	144	134	122	107	90	70	47							1866	17

POMPE SOMMERSE MULTISTADIO PER POZZI 4" MULTISTAGE SUBMERSIBLE PUMPS FOR 4" WELLS

APPLICATION

Multistage submersible water pumps for 4" deep wells (DN 100 mm). Particularly suitable for civil and industrial purposes, for sprinkler and food irrigation plants, in fire installations and generally speaking for clean water supplying.

PUMP MATERIALS

The discharge has a built-in check valve in stainless steel. The pump body is covered by a 304 polished stainless steel shell. The shafts are made from hex 304 stainless steel bar material. Shafts for pumps with 19 and fewer stages are supplied with one shaft bearing. Shafts for pumps with more than 19 stages are supplied with two shaft bearings. Impellers are made of Diffusers are made of polycarbonate. Built-in 304 stainless steel strainer. Couplings are made from sintered 304 stainless steel material, with NEMA specifications.

OPERATING CONDITIONS

- Liquid temperature up to 35°C
- Sand content max. 60 g/m³
- Start/hour 20 max.

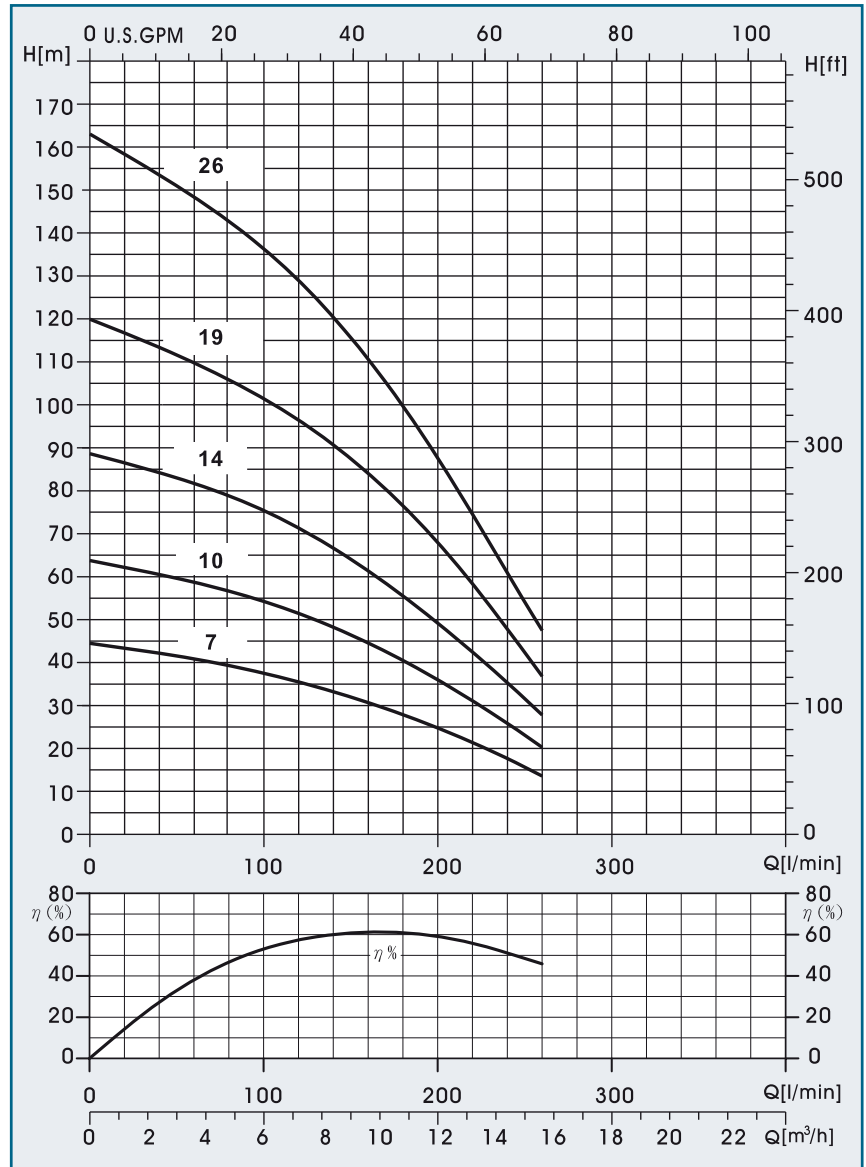

TIPO TYPE	Stadi - Stages	Potenza Power		Q = PORTATA - CAPACITY																	Dimensioni Dimensions	
				l/min 0	80	90	100	120	140	160	180	200	220	240	260	280	300	320	340	360	Length	Weight
				m ³ /h 0	4.8	5.4	6.0	7.2	8.4	9.6	10.8	12	13	14.4	16	17	18	19	20	22	(mm)	(kg)
				H = Prevalenza manometrica totale in m.C.A. - Total head in meters w.c.																		
ST60-07	7	1.5	2.0	45			37	36	33	31	28	25	22	18	14						534	5.3
ST60-10	10	2.2	3.0	64			54	52	48	44	41	36	32	26	20						690	6.7
ST60-14	14	3.0	4.0	89			76	72	67	62	56	49	43	35	28						989	8.6
ST60-19	19	4.0	5.5	120			102	97	91	89	76	68	58	48	37						1195	11.0
ST60-26	26	5.5	7.5	163			136	129	120	111	100	87	75	61	48						1559	14.3

ST 80 (2")

WORTEX

POMPE SOMMERSE MULTISTADIO PER POZZI 4"
MULTISTAGE SUBMERSIBLE PUMPS FOR 4" WELLS

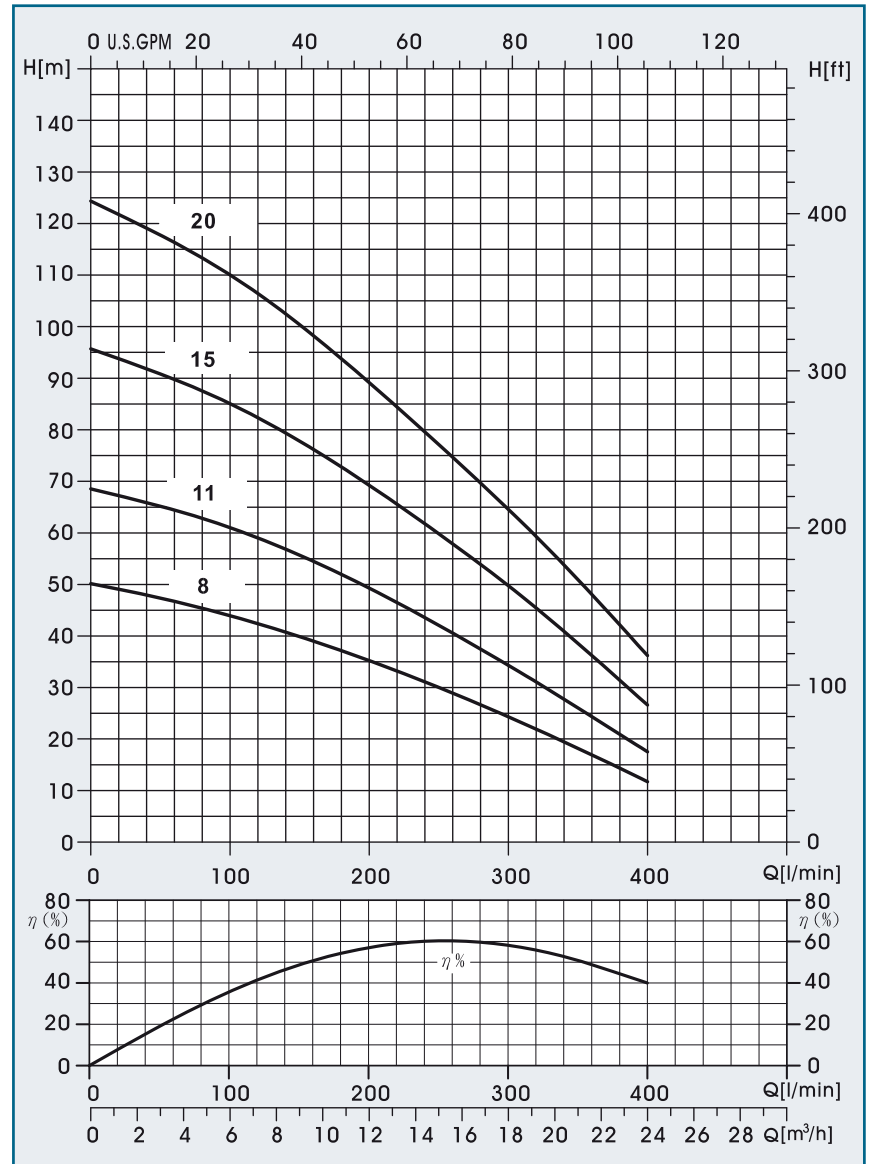

TIPO TYPE	Stadi - Stages	Potenza Power		Q = PORTATA - CAPACITY																	Dimensioni Dimensions		
				H = Prevalenza manometrica totale in m.C.A. - Total head in meters w.c.																			
		KW	HP	l/min 0	100	120	140	160	180	200	220	240	260	280	300	320	340	360	380	400	450	Length (mm)	Weight (kg)
ST80-08	8	2.2	3.0	51			41	39	37	35	33	31	29	27	24	22	20	17	14	12		676	6.3
ST80-11	11	3.0	4.0	70			57	54	52	49	47	44	41	38	34	31	28	24	21	18		880	8.1
ST80-15	15	4.0	5.5	97			79	76	73	69	66	63	58	54	50	46	41	36	32	27		1149	10.5
ST80-20	20	5.5	7.5	125			102	98	94	89	84	79	74	70	65	60	54	48	43	37		1489	13.5

4" Stainless Steel Submersible Pumps

SP 4" range of submersible pumps are made of corrosion and abrasion resistant stainless steel and have been developed in accordance with state-of-the-art technology. The SP 4" pumps are manufactured to the highest standards for energy efficiency, dependable performance, rugged construction, and long service life.

Capacity (m³/h) min 0.3 max 18

Total Head: Max. 285 m

6" Stainless Steel Submersible Pumps

SP 6" stainless steel submersible pumps are made of high quality 304 or 316 corrosion resistant stainless steel. Shafts are made of high strength 431 stainless steel. The pumps are designed for efficient and dependable performance, and a long and trouble-free life. The pumps are light in weight and ruggedly constructed for heavy duty applications.

Capacity (m³/h) min 3 max 78

Total Head: Max. 433 m

Application 4" - 6"

- ◆ Potable water supply from deep wells
- ◆ Agricultural-Irrigation, livestock watering, etc.
- ◆ Municipal and industrial
- ◆ Pressure boosting
- ◆ Mine de-watering
- ◆ Fountains, etc.

Pumped Liquids

- ◆ Clean, non-corrosive and non-abrasive liquids.

Operating Conditions

- ◆ Max. ambient temperature (Liquid): 35°C
- ◆ Sand content: Max. 50 g/m³

Features

- ◆ Stainless steel construction designed and built for years of trouble free operation
- ◆ All metal parts are made of 304 stainless steel, except for the shaft, which is made of 431 stainless steel (4")
- ◆ Heavy duty stainless steel discharge head with built-in check valve for long life and ease of installation
- ◆ Smooth safety hook (4")
- ◆ Mounting specifications are according to NEMA standards
- ◆ High quality shaft bearings providing low friction and high wear resistance
- ◆ Heavy duty stainless steel impellers & diffusers ensuring optimal performance
- ◆ Stainless steel strainer to restrict the entry of sand and other extraneous material



POMPE SOMMERSE INOX MULTISTADIO PER POZZI 4" INOX MULTISTAGE SUBMERSIBLE PUMPS FOR 4" WELLS

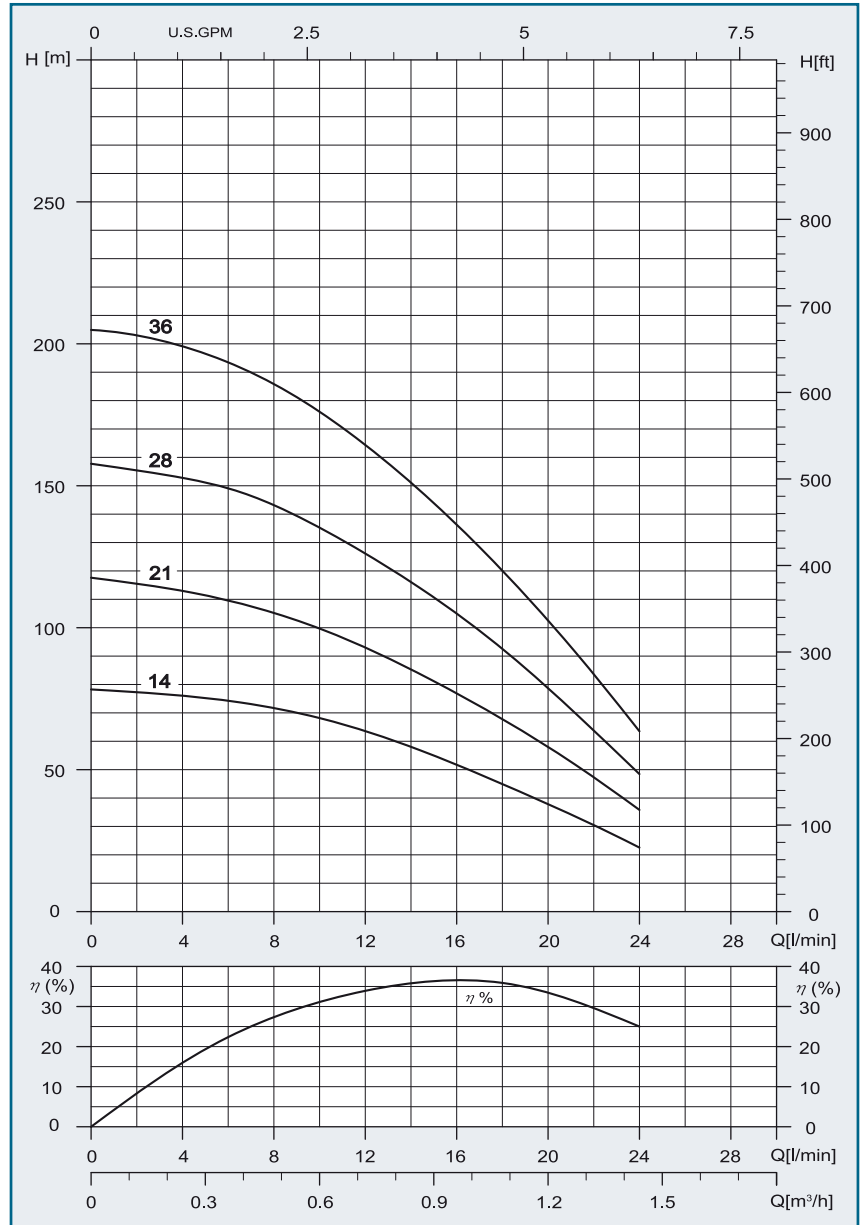

TIPO TYPE	Stadi - Stages	Potenza Power KW HP		Q = PORTATA - CAPACITY																Dimensioni Dimensions		
				l/min 0	5	10	15	20	25	30	35	40	45	50	60	70	80	90	100	120	Length	Weight
				m³/h 0	0.3	0.6	0.9	1.2	1.5	1.8	2.1	2.4	2.7	3.0	3.6	4.2	4.8	5.4	6.0	7.2	(mm)	(kg)
				H = Prevalenza manometrica totale in m.C.A. - Total head in meters w.c.																		
SP05-14	14	0,37	0,5	79	76	68	56	38	21												461	3,7
SP05-21	21	0,55	0,75	118	112	100	81	58	30												608	5,0
SP05-28	28	0,75	1,0	158	153	138	111	78	42												755	6,2
SP05-36	36	1,1	1,5	205	195	175	134	103	54												946	9,9

POMPE SOMMERSE INOX MULTISTADIO PER POZZI 4"
INOX MULTISTAGE SUBMERSIBLE PUMPS FOR 4" WELLS

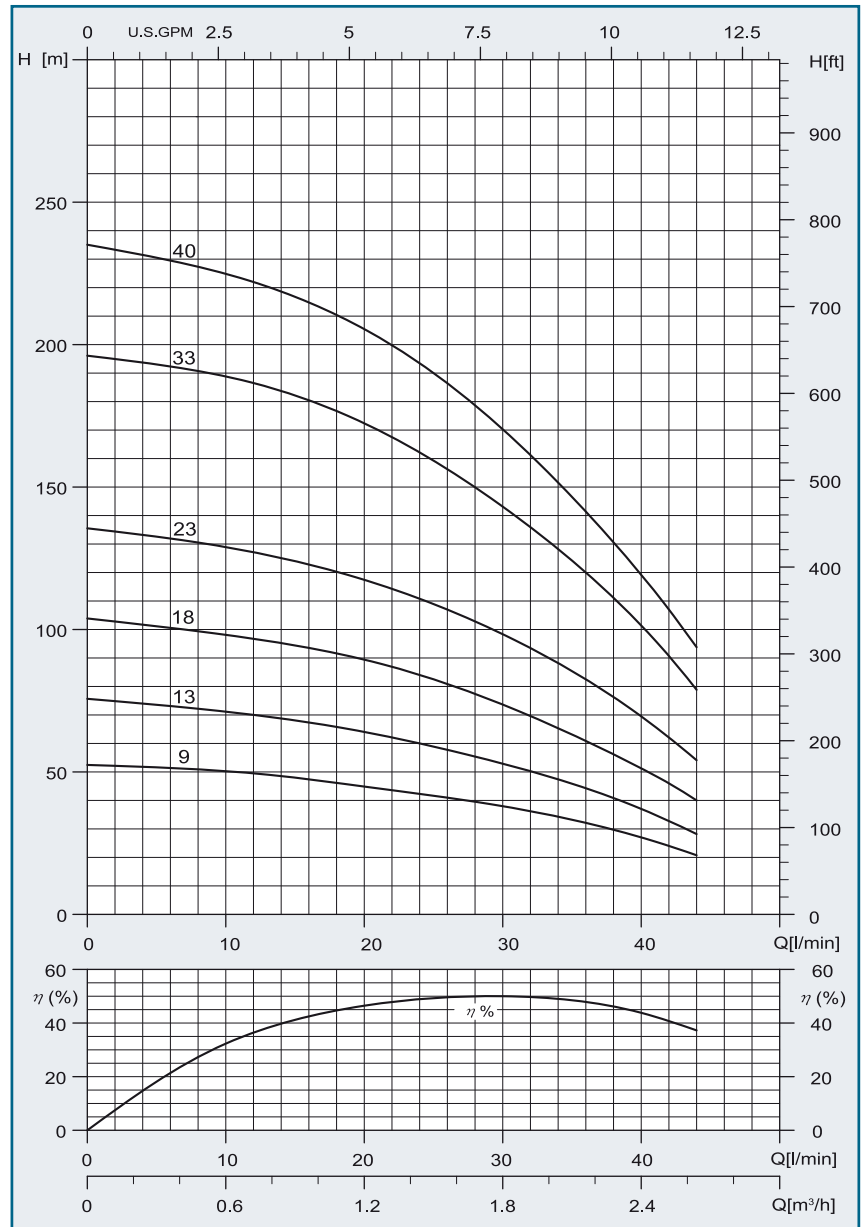

TIPO TYPE	Stadi - Stages	Potenza Power KW HP		Q = PORTATA - CAPACITY																Dimensioni Dimensions	
				l/min 0	5	10	15	20	25	30	35	40	45	50	60	70	80	90	100	Length (mm)	Weight (kg)
				m³/h 0	0.3	0.6	0.9	1.2	1.5	1.8	2.1	2.4	2.7	3.0	3.6	4.2	4.8	5.4	6.0		
				H = Prevalenza manometrica totale in m.C.A. - Total head in meters w.c.																	
SP10-09	9	0,37	0,5	53			48	45	42	38	33	26								356	3,0
SP10-13	13	0,55	0,75	77			68	64	58	54	46	38								440	3,8
SP10-18	18	0,75	1,0	104			94	89	83	74	64	51								545	4,7
SP10-23	23	1,1	1,5	136			124	118	108	98	84	69								650	5,7
SP10-33	33	1,5	2	195			183	173	159	143	124	102								883	9,7
SP10-40	40	2,2	3	235			218	205	190	170	147	119								1030	11,5

POMPE SOMMERSE INOX MULTISTADIO PER POZZI 4" INOX MULTISTAGE SUBMERSIBLE PUMPS FOR 4" WELLS

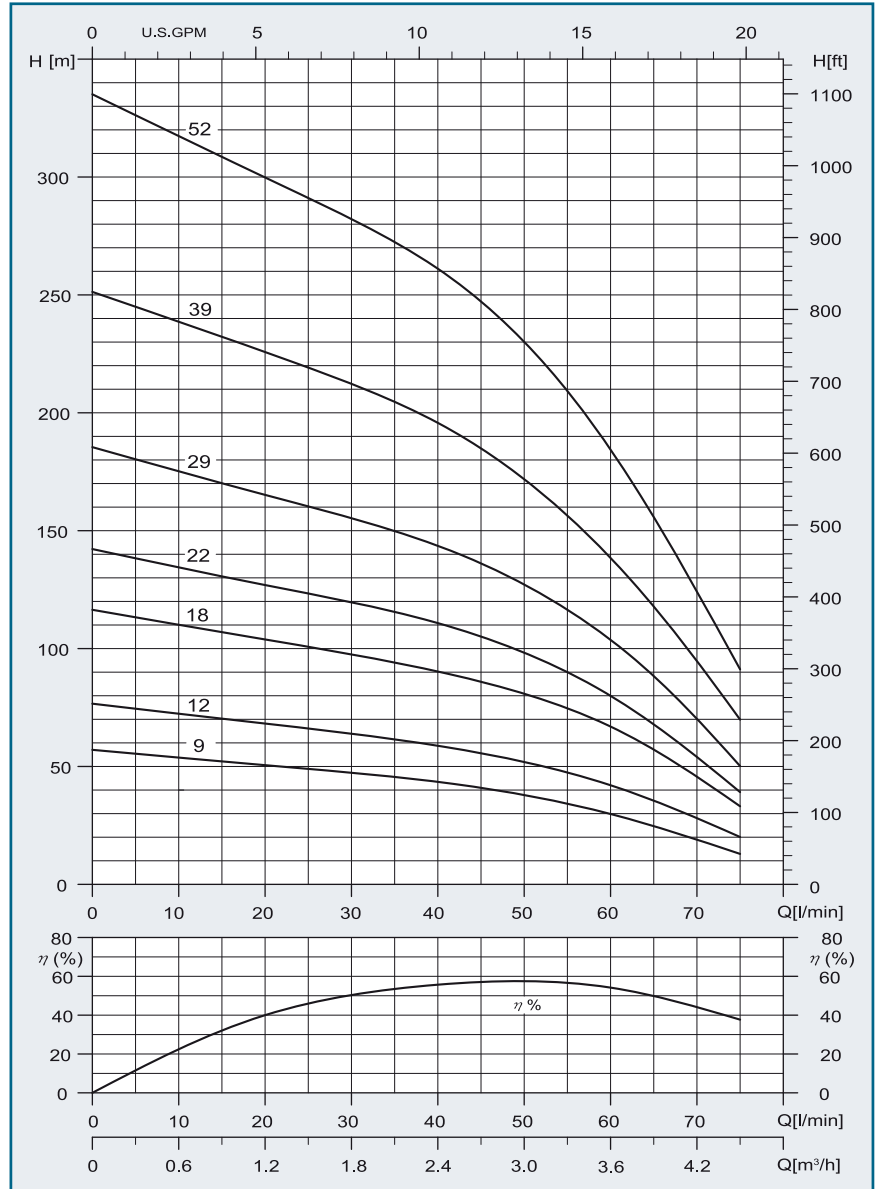

TIPO TYPE	Stadi - Stages	Potenza Power		Q = PORTATA - CAPACITY																Dimensioni Dimensions					
				l/min	0	5	10	15	20	25	30	35	40	45	50	60	70	80	90	100	120	Length (mm)	Weight (kg)		
		KW	HP	m³/h	0	0.3	0.6	0.9	1.2	1.5	1.8	2.1	2.4	2.7	3.0	3.6	4.2	4.8	5.4	6.0	7.2				
				H = Prevalenza manometrica totale in m.C.A. - Total head in meters w.c.																					
SP18-09	9	0,55	0,75	57					49	47	46	44	41	38	30	19							356	3,0	
SP18-12	12	0,75	1,0	77					66	64	62	58	56	52	43	28								419	3,6
SP18-18	18	1,1	1,5	116					101	97	94	90	85	80	67	45								545	4,7
SP18-22	22	1,5	2	143					127	120	115	110	105	97	80	54								629	5,5
SP18-29	29	2,2	3	185					160	155	149	143	136	127	103	70								776	6,8
SP18-39	39	3	4	250					219	213	204	195	185	172	138	94								1009	11,2
SP18-52	52	4	5,5	334					291	282	272	261	247	230	184	123								1282	14,5

POMPE SOMMERSE INOX MULTISTADIO PER POZZI 4" - INOX MULTISTAGE SUBMERSIBLE PUMPS FOR 4" WELLS

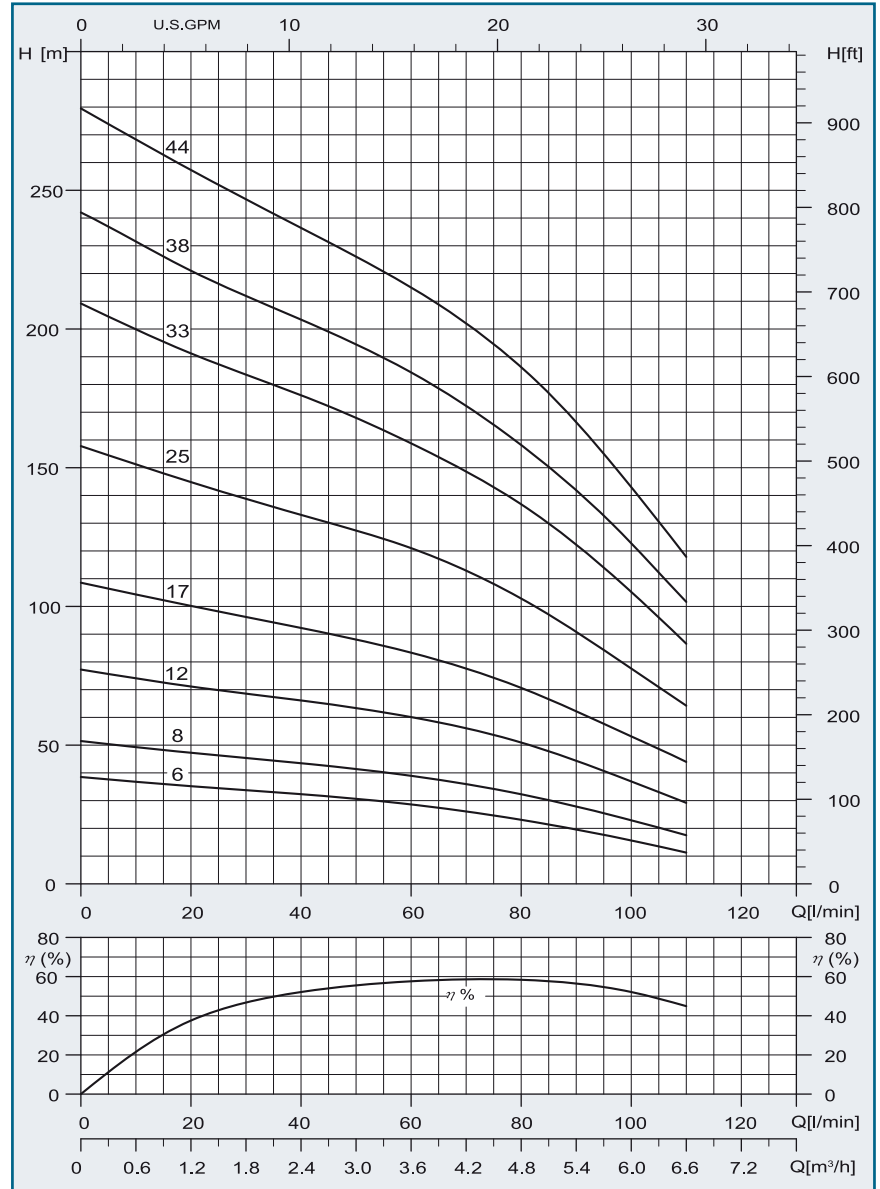

TIPO TYPE	Stadi - Stages	Potenza Power		Q = PORTATA - CAPACITY																Dimensioni Dimensions		
				l/min	0	15	20	25	30	35	40	45	50	60	70	80	90	100	120	140	160	Length
		KW	HP	m³/h	0.9	1.2	1.5	1.8	2.1	2.4	2.7	3.0	3.6	4.2	4.8	5.4	6.0	7.2	8.4	9.6	(mm)	(kg)
H = Prevalenza manometrica totale in m.C.A. - Total head in meters w.c.																						
SP25-06	6	0,55	0,75	38				34	33	32	31	30	28	26	24	20	16				293	2,4
SP25-08	8	0,75	1,0	52				45	44	43	42	41	39	36	33	28	23				335	2,8
SP25-12	12	1,1	1,5	77				68	67	66	64	63	60	56	50	44	37				419	3,6
SP25-17	17	1,5	2	108				96	94	93	90	88	84	77	70	63	54				524	4,5
SP25-25	25	2,2	3	157				138	136	133	129	127	121	113	103	90	78				692	6,0
SP25-33	33	3	4	209				184	180	176	172	168	159	149	137	123	105				868	9,6
SP25-38	38	4	5,5	242				212	208	204	199	194	185	172	158	142	123				973	10,9
SP25-44	44	4	5,5	279				247	242	237	231	226	215	202	187	166	143				1099	12,4

POMPE SOMMERSE INOX MULTISTADIO PER POZZI 4" - INOX MULTISTAGE SUBMERSIBLE PUMPS FOR 4" WELLS

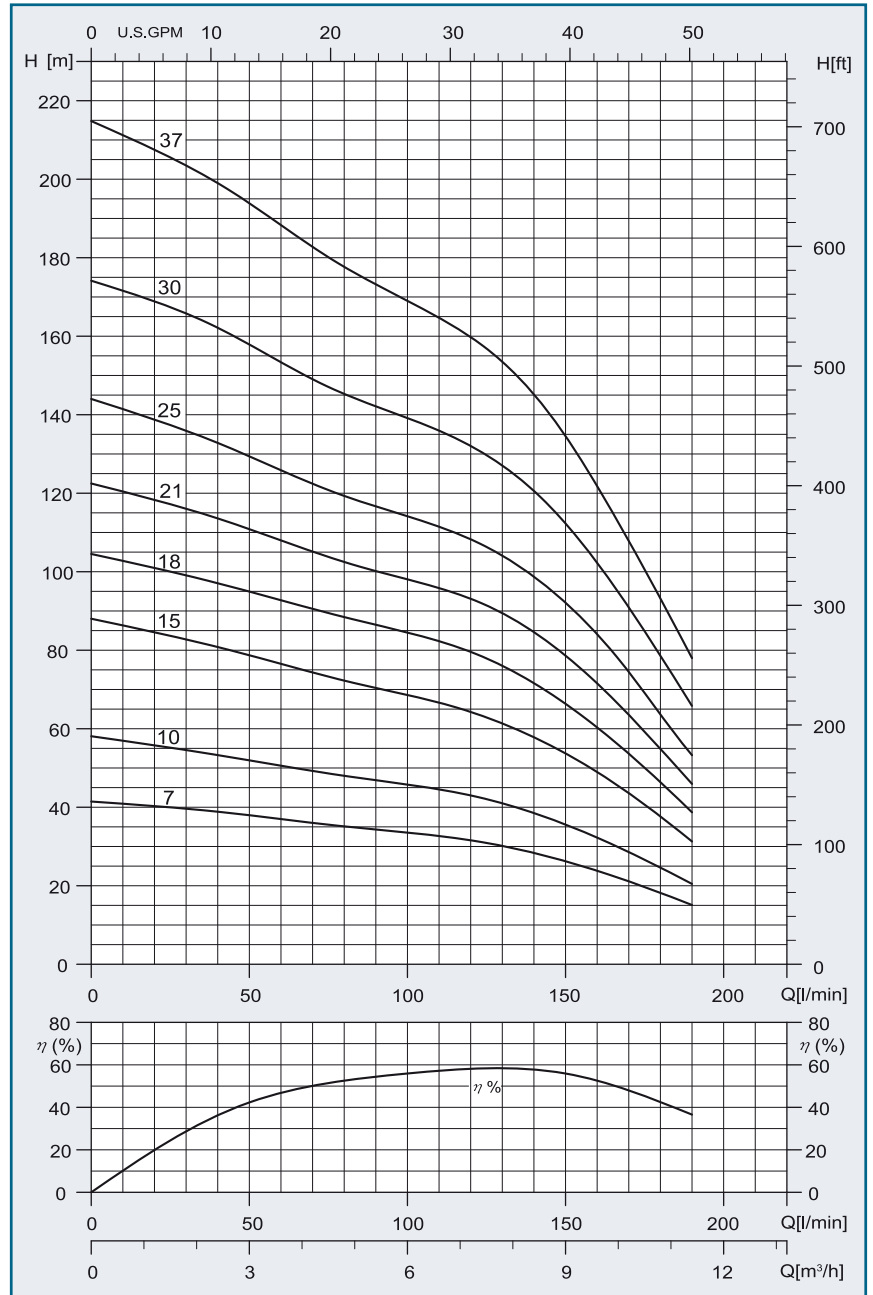

TIPO TYPE	Stadi - Stages	Potenza Power KW HP		Q = PORTATA - CAPACITY																		Dimensioni Dimensions	
				l/min 0	30	35	40	45	50	60	70	80	90	100	120	140	160	180	200	250	300	Length	Weight
				m³/h 0	1.8	2.1	2.4	2.7	3.0	3.6	4.2	4.8	5.4	6.0	7.2	8.4	9.6	10.8	12	15	18	(mm)	(kg)
				H = Prevalenza manometrica totale in m.C.A. - Total head in meters w.c.																			
SP40-07	7	1,1	1,5	41			38	37	36	36	35	35	34	34	32	27	24	17				496	5,3
SP40-10	10	1,5	2	58			54	53	52	51	49	47	47	46	43	38	32	25				622	6,8
SP40-15	15	2,2	3	87			80	79	78	76	74	72	70	68	64	57	49	38				832	9,3
SP40-18	18	3	4	104			98	96	95	93	90	88	86	84	79	72	60	47				958	10,8
SP40-21	21	4	5,5	122			114	113	111	107	105	102	100	98	93	85	72	55				1084	12,3
SP40-25	25	4	5,5	144			133	131	128	126	123	119	116	114	107	97	84	64				1252	14,3
SP40-30	30	5,5	7,5	174			163	160	157	154	149	145	142	139	131	120	103	79				1462	16,8
SP40-37	37	5,5	7,5	215			199	196	194	188	183	177	173	169	160	145	122	93				1753	20,3

POMPE SOMMERSE INOX MULTISTADIO PER POZZI 4" - INOX MULTISTAGE SUBMERSIBLE PUMPS FOR 4" WELLS

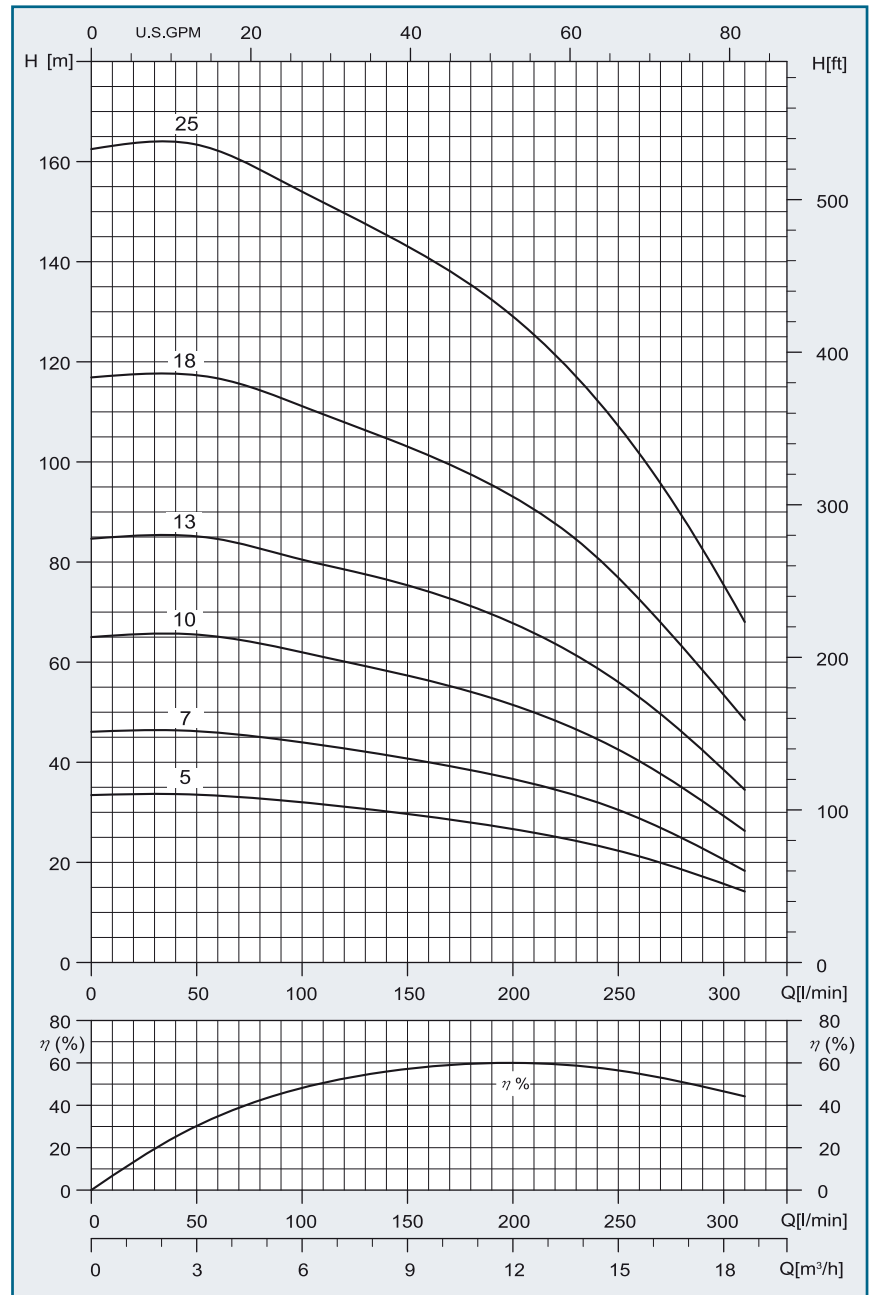

TIPO TYPE	Stadi - Stages	Potenza Power KW HP		Q = PORTATA - CAPACITY														Dimensioni Dimensions			
				l/min 0	70	80	90	100	120	140	160	180	200	250	300	320	340	360	380	Length (mm)	Weight (kg)
				m³/h 0	4.2	4.8	5.4	6.0	7.2	8.4	9.6	10.8	12	15	18	19	20	22	23		
H = Prevalenza manometrica totale in m.C.A. - Total head in meters w.c.																					
SP70-05	5	1,5	2	33					32	31	30	28	27	26	22	16				505	5,0
SP70-07	7	2,2	3	46					44	43	42	40	37	36	30	20				635	6,3
SP70-10	10	3	4	65					62	60	58	57	54	52	43	29				830	8,2
SP70-13	13	4	5,5	84					80	78	77	74	72	67	56	38				1025	10,2
SP70-18	18	5,5	7,5	117					111	108	104	102	97	93	77	54				1350	13,4
SP70-25	25	7,5	10	163					154	149	145	141	135	129	107	75				1805	17,8

SP 90 (2"1/2)

WORTEX

POMPE SOMMERSE INOX MULTISTADIO PER POZZI 6" - INOX MULTISTAGE SUBMERSIBLE PUMPS FOR 6" WELLS

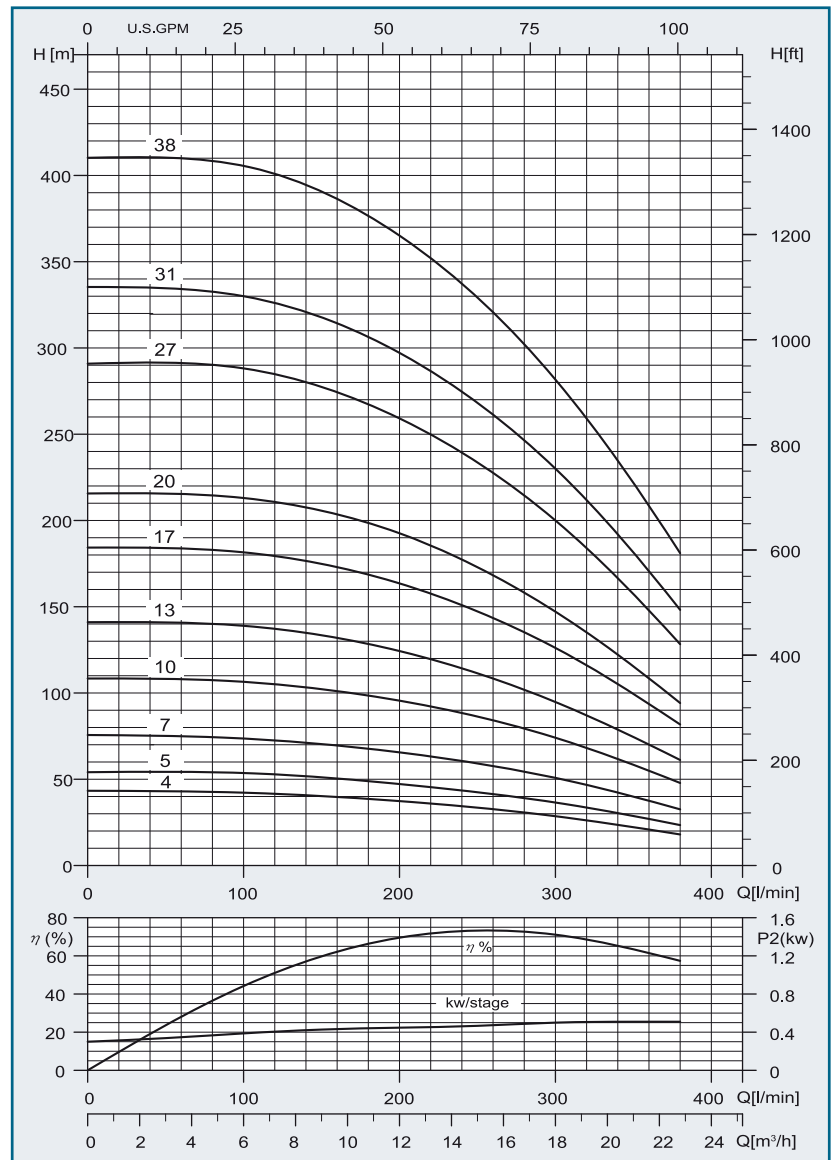

TIPO TYPE	Stadi Stages	Potenza - Power P2		Q = PORTATA - CAPACITY 2900 rpm									Dimensioni Dimensions	
		KW	HP	m³/h l/min	3	6	9	12	15	18	21	23	Length (mm)	Weight (kg)
					50	100	150	200	250	300	350	383		
SP90-04	4	2,2	3	H (m)	42,5	42	40	38	33	28,5	23	18	524	9,3
SP90-05	5	3	4		53	52	50,5	47,5	42,5	37	28,5	22	585	10,8
SP90-07	7	4	5,5		75	74	70	66	59	50,5	40	32	706	13,7
SP90-10	10	5,5	7,5		108	107	102	95	86	74	58	48	887	18
SP90-13	13	7,5	10		141	139	133	124	112	95	75	60	1069	22,4
SP90-17	17	9,3	12,5		184	182	175	163	147	126	100	80	1311	28,2
SP90-20	20	11	15		216	213	206	192	173	147	116	95	1492	32,5
SP90-27	27	15	20		291	288	277	259	234	200	158	128	1916	42,7
SP90-31	31	18,5	25		335	330	318	298	269	230	181	148	2158	48,5
SP90-38	38	22	30		410	405	390	365	330	281	222	180	2581	58,6

POMPE SOMMERSE INOX MULTISTADIO PER POZZI 6" - INOX MULTISTAGE SUBMERSIBLE PUMPS FOR 6" WELLS

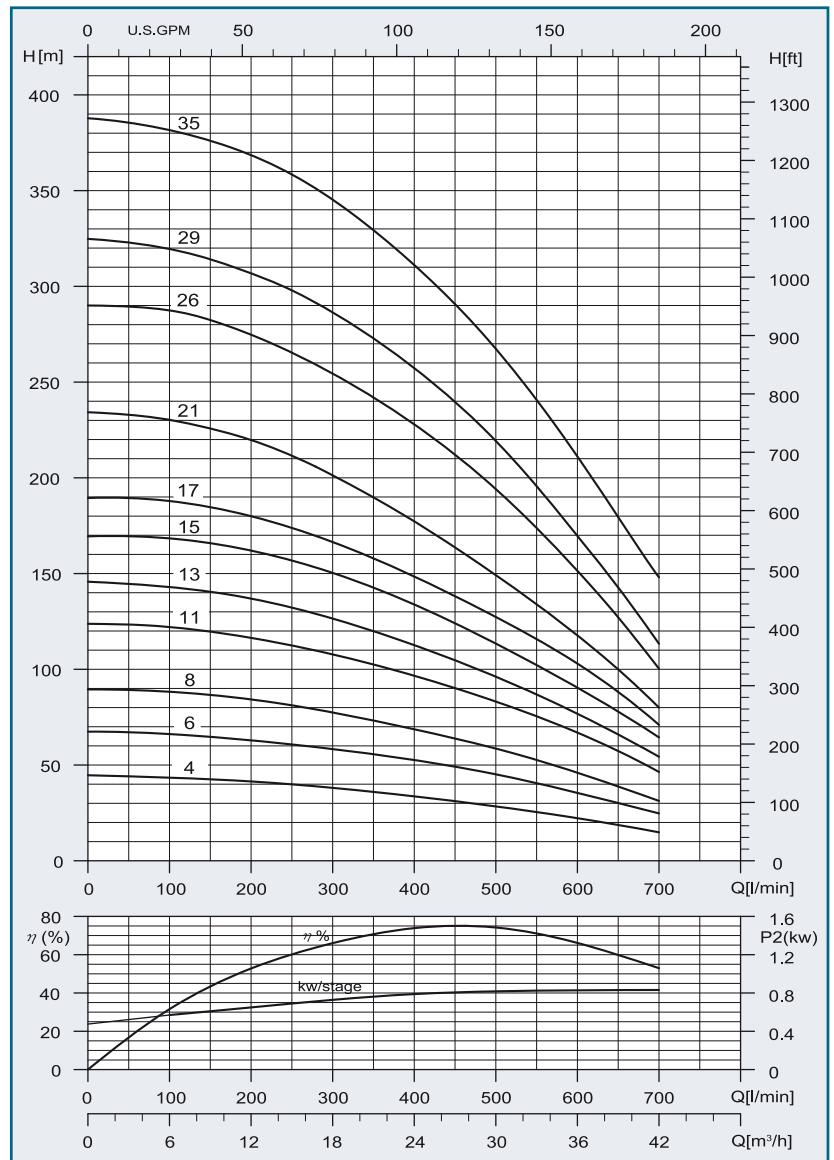

TIPO TYPE	Stadi Stages	Potenza - Power P2		Q = PORTATA - CAPACITY 2900 rpm														Dimensioni Dimensions	
		KW	HP	m³/h l/min	6	9	12	15	18	21	24	27	30	33	36	39	42	Length (mm)	Weight (kg)
SP150-04	4	3,7	5	H (m)	43	42	41	40	38	36	34	31	28	26	23	19	15	654	11,8
SP150-06	6	5,5	7,5		67	64	62	60	58	56	52	49	45	40	36	30	25	846	15,2
SP150-08	8	7,5	10		88	87	84	81	78	73	68	64	58	53	46	38	31	1038	18,6
SP150-11	11	11	15		122	120	117	112	108	102	97	90	83	76	67	57	47	1326	23,6
SP150-13	13	11	15		143	140	137	132	127	120	113	105	97	87	77	66	55	1518	27
SP150-15	15	15	20		168	166	162	157	150	142	134	124	113	102	90	77	65	1710	30,4
SP150-17	17	15	20		188	185	180	173	167	158	148	138	127	116	103	88	71	1902	33,8
SP150-21	21	18,5	25		230	226	220	212	202	190	177	164	149	134	117	100	80	2286	40,6
SP150-26	26	22	30		287	282	275	266	255	242	227	212	194	173	152	127	100	2766	49
SP150-29	29	26	35		319	314	307	298	287	273	257	240	220	196	170	143	113	3054	54,1
SP150-35	35	30	40	382	377	368	358	346	329	311	290	267	240	211	180	148	3630	64,3	

SP 230 (3")

WORTEX

POMPE SOMMERSE INOX MULTISTADIO PER POZZI 6" - INOX MULTISTAGE SUBMERSIBLE PUMPS FOR 6" WELLS

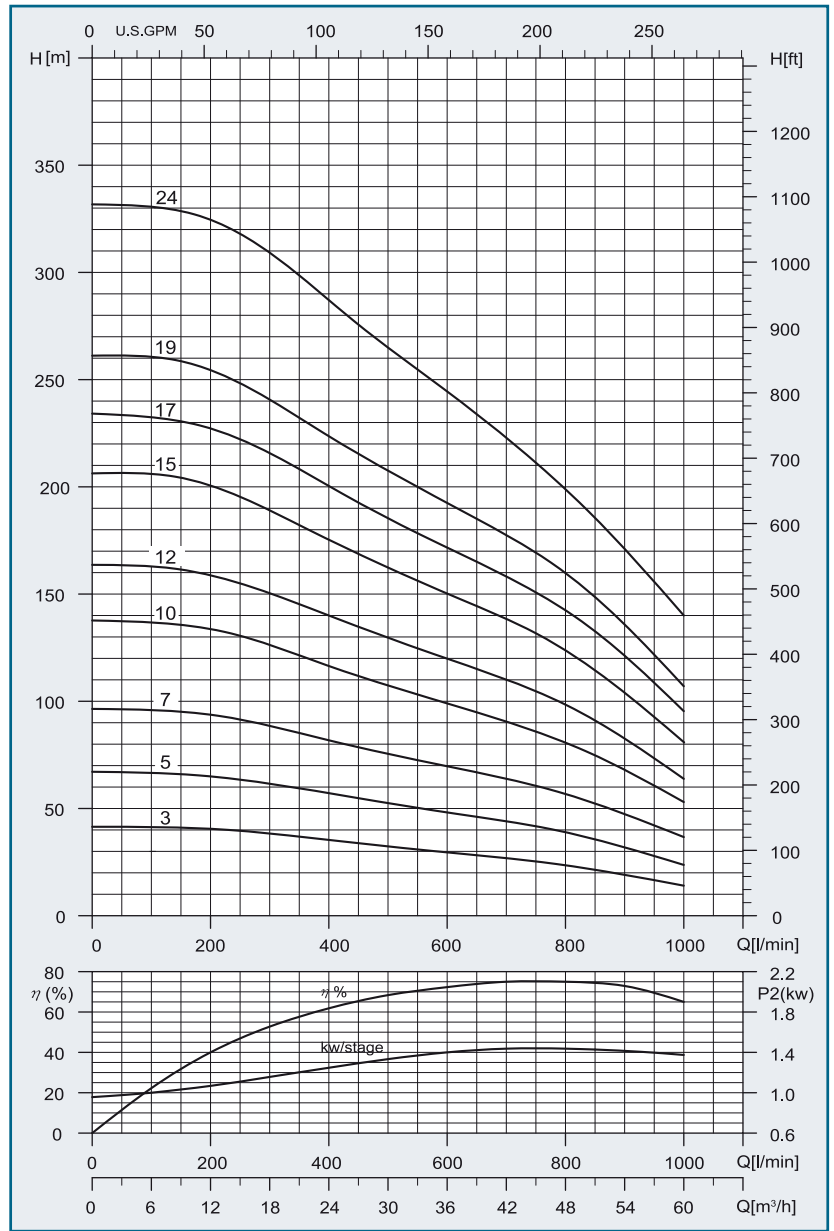

TIPO TYPE	Stadi Stages	Potenza - Power P2		Q = PORTATA - CAPACITY 2900 rpm													Dimensioni Dimensions	
				m³/h l/min	12	15	18	21	24	27	30	36	42	48	54	60		
		KW	HP		H (m)	200	250	300	350	400	450	500	600	700	800	900	1000	
SP230-03	3	5,5	7,5	H (m)	40	39	38	37	35	34	33	29	27	23	18	14	609	11,5
SP230-05	5	7,5	10		65	63	61	59	57	55	53	48	44	39	32	24	835	16
SP230-07	7	11	15		94	92	88	85	82	79	76	70	64	57	47	37	1061	20,6
SP230-10	10	15	20		133	130	127	122	117	112	107	98	90	80	67	53	1400	27,4
SP230-12	12	18,5	25		158	155	150	145	140	135	130	120	110	98	83	64	1626	32
SP230-15	15	22	30		200	195	189	183	176	169	163	150	138	124	103	81	1965	38,8
SP230-17	17	26	35		227	222	215	208	200	193	186	172	158	143	121	96	2191	43,4
SP230-19	19	30	40		254	248	241	233	224	216	208	193	178	160	136	107	2417	47,9
SP230-24	24	37	50		325	317	309	298	287	276	265	244	223	199	171	140	2982	59,3

POMPE SOMMERSE INOX MULTISTADIO PER POZZI 6" - INOX MULTISTAGE SUBMERSIBLE PUMPS FOR 6" WELLS

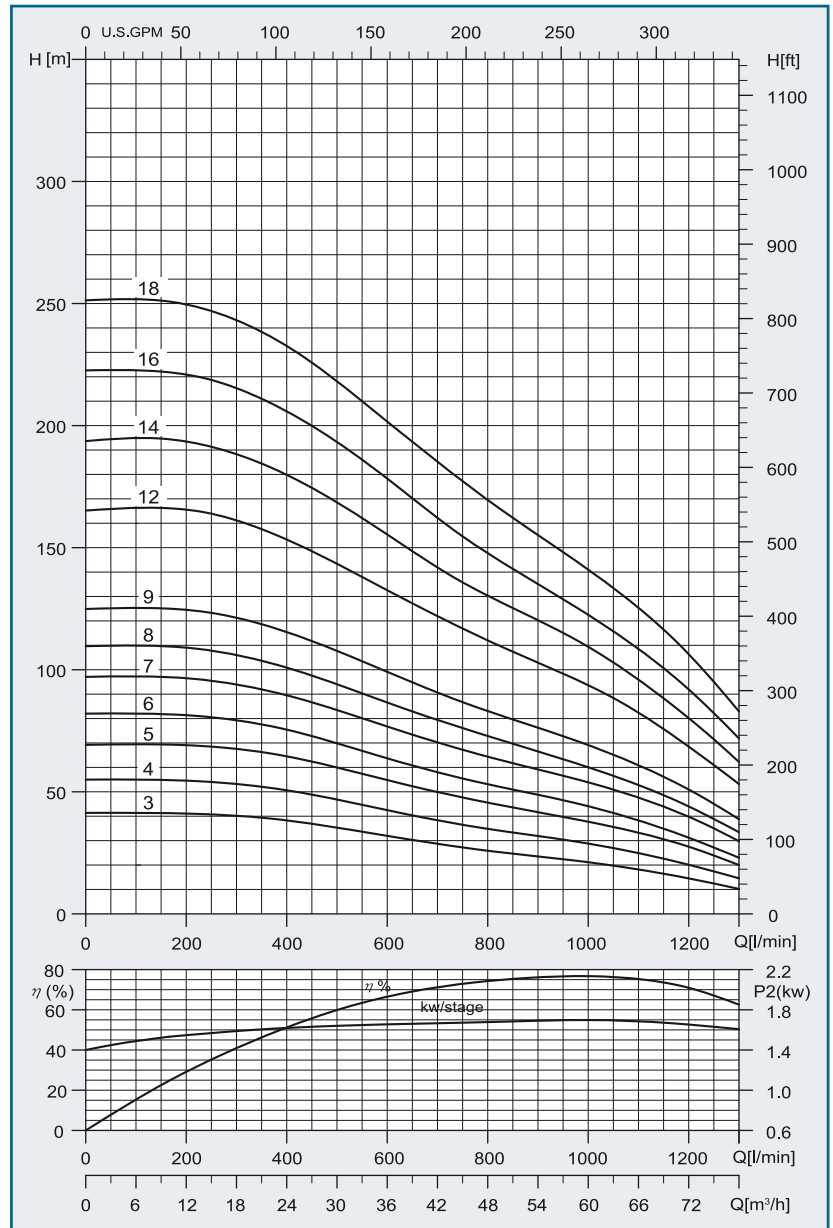

TIPO TYPE	Stadi Stages	Potenza - Power P2		Q = PORTATA - CAPACITY 2900 rpm													Dimensioni Dimensions		
		KW	HP	m³/h l/min	18	21	24	27	30	36	42	48	54	60	66	72	78	Length (mm)	Weight (kg)
SP300-03	3	5,5	7,5	H (m)	40	39	38	37	36	32	28	26	24	21	18	14	10	609	11,5
SP300-04	4	7,5	10		53	52	51	48	47	43	38	35	32	28	25	20	14	722	13,7
SP300-05	5	9,3	12,5		67	66	64	62	60	55	50	46	42	38	33	27	19	835	16
SP300-06	6	11	15		79	78	76	73	70	64	58	53	48	44	38	32	23	948	18,3
SP300-07	7	13	17,5		94	92	89	86	84	77	70	64	59	54	47	40	29	1061	20,6
SP300-08	8	15	20		106	104	101	97	94	87	80	73	67	60	53	44	33	1174	22,9
SP300-09	9	18,5	25		122	118	116	112	108	99	91	83	76	69	61	51	38	1287	25,1
SP300-12	12	22	30		162	157	153	148	143	133	122	112	103	94	83	68	53	1626	32
SP300-14	14	26	35		188	184	180	175	168	156	142	130	120	109	96	80	63	1852	36,5
SP300-16	16	30	40		216	211	206	200	193	178	162	148	135	123	108	92	72	2078	41,1
SP300-18	18	37	50	243	238	233	226	218	202	185	170	155	141	126	107	83	2304	45,7	

4" SUBMERSIBLE MOTOR

APPLICATION

WORTEX rewindable 4" oil filled submersible motors are designed to operate dependably in 4" and larger boreholes.

FEATURES

- 💧 Removable waterproof cable connector for easy maintenance operations.
- 💧 Cable materials are CE approved (for potable water applications).
- 💧 Non-toxic oil - Premium quality, colorless white oil meeting the requirements of international and national authorities for pharmaceutical white oils.
- 💧 Special stator design for high starting torque in single-phase models.
- 💧 Unique single-phase electrical design for PSC starting, and starting capacitor + PSC starting.
- 💧 Motor casing, shaft, upper cover and bottom end made of stainless steel.
- 💧 Zinc-plated cast iron upper bracket.
- 💧 Stators are designed for higher efficiency and the ability to operate within wider voltage fluctuations.
- 💧 All motors 100% tested.

GENERAL SPECIFICATIONS

Mounting flage	4" NEMA standard
Degree of protection	IP 68
Insulation class	F
Single phase motors	0.37 kW up to 3.7 kW
Three phase motors	0.37 kW up to 7.5 kW
Standard voltages	1~ 230V(50Hz) 1~ 110V or 230V(60Hz) 3~ 230V or 400V (50Hz) 3~ 230V or 400V (60Hz)
Cable length	1.7 M 0.37 kW up to 1.5 kW 2.5 M 2.2 kW up to 7.5 kW

OPERATING PARAMETERS

Max voltage variation	+ 10% / - 10%
Max starts / h	40
Max water temperature	35°C
Flow rate	0.2m/sec
Axial thrust	2000N from 0.37 kW up to 1.5 kW 3000N 2.2 kW 5000N from 3 kW up to 7.5 kW
Max immersion depth	200m

MATERIAL SPECIFICATIONS

Component	Material
Motor Shell	304 Stainless steel
Sand Guard	NBR
Cable Connector	EPDM
Upper end bracket cover	304 Stainless steel
Upper end bracket	Zinc plated cast iron
Mechanical seal	Ceremic/Carbon
Shaft (0.5 - 3 HP)	304 Stainless steel
Shaft (4 - 10HP)	630 Stainless steel
Rotor (0.5 - 3 HP)	Aluminum
Rotor (4 - 10HP)	Copper
Connector	PPS
Winding	Copper
Lower end bracket	Aluminum
Lower end bracket cover	304 Stainless steel
Diaphragm	NBR

Note:
Specifications subject to change without notice.



TECHNICAL DATA

SINGLE-PHASE MOTORS 50 Hz

Motor Type	P2		Voltage V	In A	Istart A	Efficiency	PF COSφ	RPM	Thrust Load N	Capacitor μF	Cable	
	kW	HP									mm ²	m
MW 0,5	0.37	0.5	230	3.7	12	0.53	0.95	2840	2000	16	1.5	1.7
MW 0,75	0.55	0.75	230	5	15	0.62	0.90	2840	2000	20	1.5	1.7
MW 1	0.75	1	230	6.2	20	0.64	0.90	2840	2000	25	1.5	1.7
MW 1,5	1.1	1.5	230	8.1	32	0.68	0.90	2850	2000	35	1.5	1.7
MW 2	1.5	2	230	10.4	38	0.73	0.90	2850	2000	40	1.5	1.7
MW 3	2.2	3	230	15	46	0.72	0.88	2820	3000	55	1.5	2.5

THREE-PHASE MOTORS 50 Hz

Motor Type	P2		Voltage V	In A	Istart A	Efficiency	PF COSφ	RPM	Thrust Load N	Cable	
	kW	HP								mm ²	m
MWt 0,5	0.37	0.5	400	1.6	4.5	0.60	0.78	2820	2000	1.5	1.7
MWt 0,75	0.55	0.75	400	1.9	6.7	0.64	0.78	2830	2000	1.5	1.7
MWt 1	0.75	1	400	2.3	8.9	0.66	0.78	2830	2000	1.5	1.7
MWt 1,5	1.1	1.5	400	3.1	12	0.70	0.84	2840	2000	1.5	1.7
MWt 2	1.5	2	400	4	14	0.72	0.84	2840	2000	1.5	1.7
MWt 3	2.2	3	400	5.6	22	0.71	0.83	2840	3000	1.5	2.5
MWt 4	3	4	400	7.4	43	0.73	0.80	2850	5000	1.5	2.5
MWt 5,5	4	5.5	400	9.8	49	0.75	0.80	2855	5000	1.5	2.5
MWt 7,5	5.5	7.5	400	13.7	65	0.75	0.80	2850	5000	1.5	2.5
MWt 10	7.5	10	400	18.7	87	0.76	0.80	2850	5000	1.5	2.5



Leak free, o-ring sealed air valve cap

Epoxy coating finish

Butyl diaphragm

Polypropylene liner

Stainless steel connector

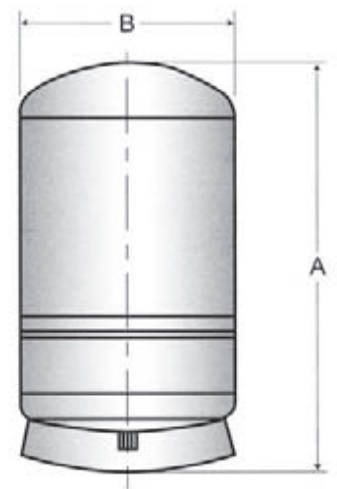
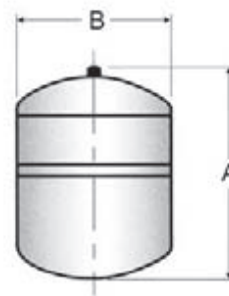
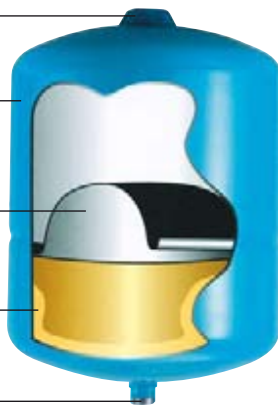

MODEL	VOLUME liter	DIMENSIONS		CONNECTION	SHIPPING Volume (box)	SHIPPING Weight
		A mm	B mm			
SPTB 8	8	300	202	1"	0.016 cu. M	2.5 kg
SPTB 18	18	380	276	1"	0.031 cu. M	4.2 kg
SPTB 24	24	420	290	1"	0.041 cu. M	4.7 kg
Vertical Models with base						
SPTB 58	58	560	390	1"	0.099 cu. M	11.5 kg
SPTB 80	80	680	390	1"	0.131 cu. M	13.0 kg
SPTB 160	160	910	560	1 1/4"	0.313 cu. M	41.0 kg

All connections are stainless steel. All tanks are pre-charged at 2 bar unless stated otherwise.
Maximum Working Pressure: 10 bar. Maximum Working Temperature: 90° C.



IDROSFERA A MEMBRANA *MEMBRANE PRESSURE TANK*

TIPO - TYPE	PRESSIONE MAX. MAX. PRESSURE	CAPACITÀ LITRI CAPACITY LITERS	RACCORDO CONNECTOR
ISV 24	8 bar	24	1"



IDROPRESS A MEMBRANA *MEMBRANE PRESSURE TANK*

TIPO - TYPE	PRESSIONE MAX. MAX. PRESSURE	CAPACITÀ LITRI CAPACITY LITERS	RACCORDO CONNECTOR
IPH 22	8 bar	22	1"
IPH 25	8 bar	25	1"
IPH 40	10 bar	40	1"
IPH 50	10 bar	50	1"
IPH 60	10 bar	60	1"
IPH 80	10 bar	80	1"
IPH 100	10 bar	100	1"
IPH 200	10 bar	200	1"1/2
IPH 300	10 bar	300	1"1/2



IDROSFERA A MEMBRANA *MEMBRANE PRESSURE TANK*

TIPO - TYPE	PRESSIONE MAX. MAX. PRESSURE	CAPACITÀ LITRI CAPACITY LITERS	RACCORDO CONNECTOR
ISV 50	10 bar	50	1"
ISV 60	10 bar	60	1"
ISV 80	10 bar	80	1"
ISV 100	10 bar	100	1"
ISV 200	10 bar	200	1"1/2
ISV 300	10 bar	300	1"1/2
ISV 500	10 bar	500	1"1/2
ISV 750	10 bar	750	1"1/2
ISV 1000	10 bar	1000	2"



SET ISV 24

COMPONENTI - COMPONENTS

- Serbatoio 24 lt. verticale - *Vertical tank 24 lt.*
- Manometro scala 0÷6 bar - *Pressure gauge*
- Raccordo ottone 5 vie - *5 ways connector*
- Pressostato - *Pressure switch*



SET IPH 25

COMPONENTI - COMPONENTS

- Serbatoio 25 lt. orizzontale - *Horizontal tank 25 lt.*
- Manometro scala 0÷6 bar - *Pressure gauge*
- Tubo flessibile 520 mm - *Flexible hose*
- Raccordo ottone 5 vie - *5 ways connector*
- Pressostato - *Pressure switch*



PRESSOSTATO *PRESSURE SWITCH*

TIPO - TYPE	MISURA SIZE	RACCORDO CONNECTOR
PSF 5	1,6 ÷ 3,2 bar	1/4" Femmina/Female
PSM 5	1,6 ÷ 3,2 bar	1/4" Maschio/Male



PRESSOSTATO *PRESSURE SWITCH*

TIPO - TYPE	MISURA SIZE	RACCORDO CONNECTOR
PST 2	1,4 ÷ 2,8 bar	1/4" Femmina/Female



TUBO FLESSIBILE ANTIVIBRANTE *ANTI VIBRATION FLEXIBLE HOSE*

TIPO - TYPE	MISURA SIZE	RACCORDO CONNECTOR
FLEXI 30 R	300 mm	1/2" Raccordato/Bended
FLEXI 52 R	520 mm	1" Raccordato/Bended
FLEXI 60 D	600 mm	1" Diritto/Right



MANOMETRO *PRESSURE GAUGE*

TIPO - TYPE	MISURA SIZE	RACCORDO CONNECTOR
PGP 40	Ø 40	1/4"
PGR 50	Ø 50	1/4"



RACCORDO OTTONE *BRASS CONNECTOR*

TIPO - TYPE	MISURA SIZE
BC 3 V	1"
BC 4 V	1"
BC 5 V	1"



VALVOLA DI FONDO *FOOT VALVE*

TIPO - TYPE	MISURA SIZE
FTS 1	1"



VALVOLA DI FONDO *FOOT VALVE*

TIPO - TYPE	MISURA SIZE
FV 1	1"



VALVOLA DI RITEGNO *CHECK VALVE*

TIPO - TYPE	MISURA SIZE
CV 1"	1"
CV 1" 1/4	1"1/4
CV 1" 1/2	1"1/2



FILTRI ACQUA *WATER FILTER*

TIPO - TYPE	PRESSIONE MAX. MAX. PRESSURE	MISURA SIZE	ALTEZZA HEIGHT
WF 5	3,5 bar	1" x 1"	5"
WF 9	3,5 bar	1" x 1"	9"



CARTUCCIA FILTRO *FILTER CARTRIDGE*

TIPO - TYPE	DIAMETRO DIAMETER	ALTEZZA HEIGHT
CWF 5	63	112
CWF 9	63	243



GALLEGGIANTE *FLOATER*

TIPO - TYPE	MISURA SIZE
IGD 2/S	2 mt.
IGD 5/S	5 mt.
IGD 10/S	10 mt.

ACCESSORI ACCESSORIES



SET MANDATA DELIVERY SET

TIPO - TYPE	MISURA SIZE
DS 28	1" x 28
DS 35	1"1/4 x 35
DS 40	1"1/2 x 40
DS 50	2" x 50



SET ASPIRAZIONE SUCTION SET

TIPO - TYPE	MISURA SIZE
SA 4	1" x 1"
SA 7	1" x 1"



REGOLATORE DI PRESSIONE PER ELETTROPOMPE PRESSURE REGULATOR FOR ELECTRIC PUMPS

TIPO - TYPE	MISURA SIZE
EUROPRESS <i>with cable</i>	1"



REGOLATORE DI PRESSIONE PER ELETTROPOMPE PRESSURE REGULATOR FOR ELECTRIC PUMPS

TIPO - TYPE	MISURA SIZE
EUROPRESS <i>without cable</i>	1"



REGOLATORE DI PRESSIONE PER ELETTROPOMPE PRESSURE REGULATOR FOR ELECTRIC PUMPS

TIPO - TYPE	MISURA SIZE
FLUSSMATIC <i>with cable</i>	1"



REGOLATORE DI PRESSIONE PER ELETTROPOMPE PRESSURE REGULATOR FOR ELECTRIC PUMPS

TIPO - TYPE	MISURA SIZE
FLUSSMATIC <i>without cable</i>	1"